

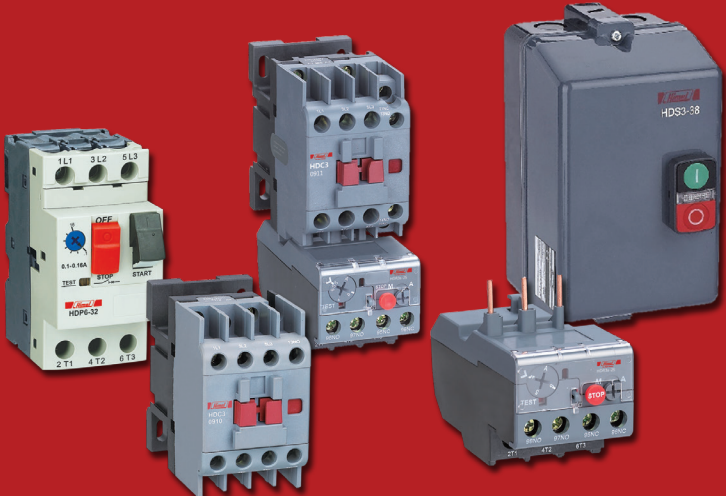

Motor Control & Protection





About Himel

Himel is a multinational manufacturer and provider of electrical products successfully combining global expertise with local knowledge.

Founded by a Spanish entrepreneur in 1958, the company pioneered in exporting quality electrical enclosures, establishing Himel brand globally. Today, our global footprint and technology enable us to provide the best combination of affordable and reliable offers for Low Voltage Power distribution, Industry Automation and Home Electric to our long-term customers and partners in over 50 countries where we are present.

Himel. Reliable made affordable



MOTOR MANAGEMENT



MOTOR MANAGEMENT

HDC3 AC Contactors



HDC3

Rated current: 6-95A
Pole: 3P
* 120~630A available early 2021

01

HJX2-F 4P AC Contactors



HJX2-F 4P

Rated current: 115-800A
Pole: 4P

30

HDR3s Thermal Overload Relays



HDR3s

Frame rated current: 25, 38, 93A
Setting current: 0.1-93A
* 120~630A available early 2021

19

HJSZ3 Electronic Time Relays



HJSZ3

Rated Voltage: AC 120, 240, 400V DC 125, 250V
Delay after power-on : 0.05s-24h,
Delay after power-off : 0.1s-30M

38

HJX2 4P AC Contactors



HJX2 4P

Rated current: 9-95A
Pole: 4P

28

HXJ9 Phase Failure and Sequence Protection Relays



HXJ9

Rated voltage : 380, 400V
Overvoltage : 380-460V, 400-480V
Undervoltage : 300-380V, 320-400V

41

HDC17K Miniature AC Contactors



HDC17K

Rated current: 6-12A
Pole: 3P/4P

42

HDP6 Motor Circuit Breakers



HDP6

Frame rated current: 32/80A
Setting Current : 0.1-0.16A,..., 24-32A, 40-80A

49

HDZ3 Contactor Relays



HDZ3

Pole: 3P

46

HDS3 Magnetic Starters



HDS3

Frame current: 38A, 95A
Rated current: 09-95A
Protection level: IP54

57

MOTOR MANAGEMENT

HDC3 AC Contactors

Standard: IEC60947-4

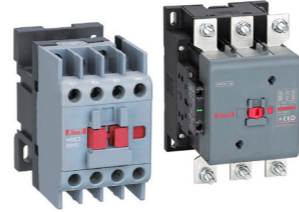

Range Presentation

HDC3 is Himel 3 series range of contactors designed for Motor Control AC3 applications up to 630A .

HDC3 contactors are applicable to AC power systems 50Hz or 60Hz with rated operating voltage up to 690V.

HDC3 contactors can be combined with HDR3s thermal overload relays to form magnetic motor starters up to 630A.

Features

- ◆ 5 frame sizes: 25, 38, 95, 225, 630A
- ◆ Wide range of operating voltage from 70%~120% Us
- ◆ Full range of accessories for any type of application
- ◆ Can be combined with HDR3s thermal overload relay

Online Content



HDC3

Selection Code

Range name	Current specification	Reversible	Auxiliary contact	Coil voltage	Coil frequency
HDC3	06	N	11	M	5
06-95A	06: 06A 09: 09A 12: 12A 18: 18A 25: 25A 32: 32A 38: 38A 40: 40A 50: 50A 65: 65A 80: 80A 95: 95A	N: reversible AC Contact with mechanical interlock Default: AC Contact	06A: 01: 1NC 10: 1NO 09-95A: 11: 1NO+1NC	B: 24V C: 36V E: 48V F: 110V S: 127V M: 220/230V U: 240V Q: 380/400V L: 415V X: 440V	5: 50Hz 7: 50/60Hz
120-630A	120: 120A 160: 160A 185: 185A 225: 225A 265: 265A 330: 330A 400: 400A 500: 500A 630: 630A	Default: AC Contact	22: 2NO+2NC	F: 110V S: 127V M: 220V Q: 380V EHE7: 48-130V KUE7: 100-250V URE7: 250-500V	5: 50Hz 7: 50/60Hz

Note: 265-630A only wide coil voltage ratings available (EHE7 , KUE7 , URE7)

MOTOR MANAGEMENT

HDC3 AC Contactors

Standard: IEC60947-4



Overview of Accessories

HDC3 09-95A Accessories

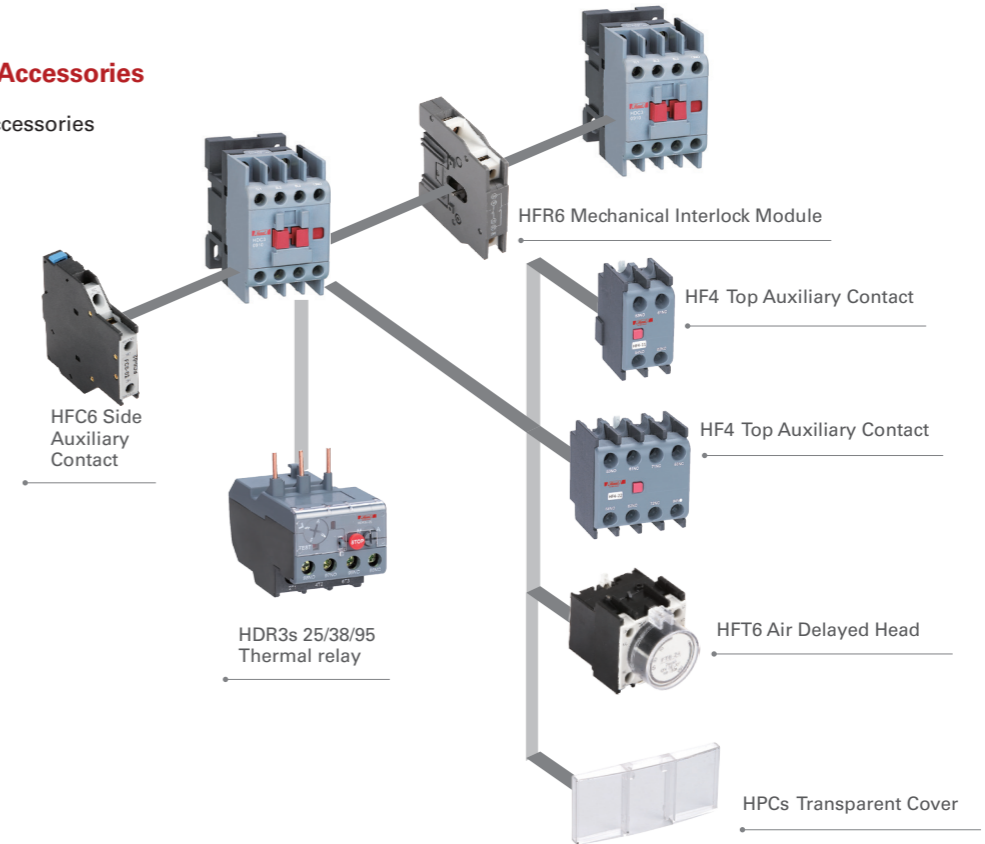

HDC3 120-630A Accessories

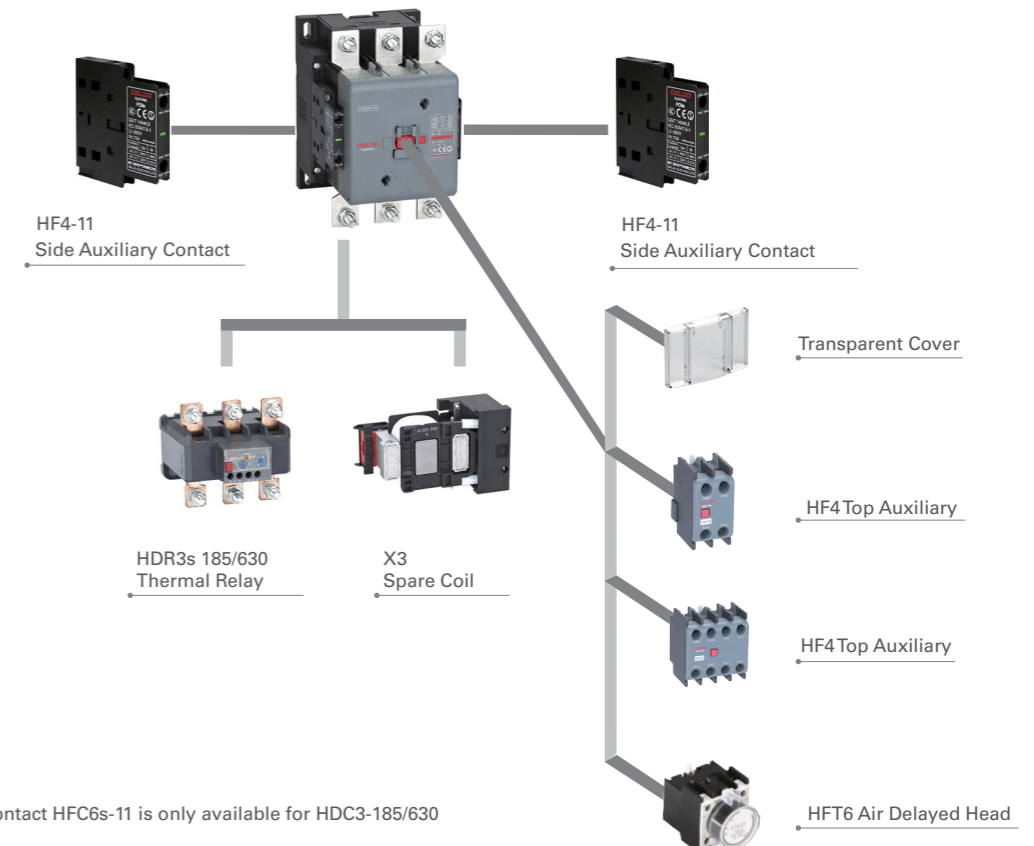

Note: Side Auxiliary Contact HFC6s-11 is only available for HDC3-185/630

HDC3 AC Contactors

Standard: IEC60947-4



Technical Parameter														
AC Contactors			HDC3											
Contactor model			06	09	12	18	25	32	38	40	50	65	80	95
Main circuit characteristics														
Conventional thermal current(Ith)	380/400V	A	25	25	25	32	40	50	50	60	80	80	125	125
		A	6	9	12	18	25	32	38	40	50	65	80	95
Rated operating current (Ie)	220/230V	kW	1.1	2.2	3	4	5.5	7.5	11	11	15	18.5	22	25
		kW	2.2	4	5.5	7.5	11	15	18.5	18.5	22	30	37	45
Rated operating power(Pe) AC-3	380/400V	kW	2.2	4	5.5	7.5	11	15	18.5	18.5	22	30	37	45
		kW	3	5.5	7.5	10	15	18.5	18.5	30	33	37	45	45
Mechanical endurance	10k times	1200			1000			900			650			
		110			90			65						
Electrical endurance	AC-3	10k times	110			90			65					
		Times/hour	1200			600								
Operation frequency			1200			600								
Number of poles			3P											
Rated insulation voltage(Ui)			690											
Maximum rated operating voltage(Ue)			660/690											
Certificate			CB, CE, SEMKO											
Coil														
Rated control circuit voltage(Us)	50Hz	V	24, 36, 48, 110, 127, 220/230, 240, 380/400, 415, 440											
	50/60Hz	V	24,36, 48, 110, 127, 220/230, 240, 380/400, 415, 440											
Allowable control circuit voltage(Us)	Operation	V	AC:70%~120% (vertical installation)											
	Drop-out	V	AC: 20%-75%											
Coil power	Actuation	VA	50	60	70	200	200							
	Holding	VA	6-9.5	6-9.5	6-9.5	15-20	15-20							
Main circuit terminal wiring capability														
Soft wire	1 wire	mm ²	1...4			1.5...6			2.5..25			4...50		
	2 wire	mm ²	1...4			1.5...6			2.5..16			4...25		
Hard wire	1 wire	mm ²	1...4			1.5...6		1.5...10		2.5..25			4...50	
	2 wire	mm ²	1...4			1.5...6		1.5...6		2.5..10			4...25	
Auxiliary contact														
Conventional thermal current(Ith)			A 10											
Rated operating voltage	AC	V	380											
	DC	V	220											
Rated control capacity	AC-15	VA	380											
	DC-13	W	33											

HDC3 AC Contactors

Standard: IEC60947-4









Main technical parameter													
Contactor Model			HDC3										
Contactor model			120	160	185	225	265	330	400	500	630		
Main Circuit Characteristic													
Conventional thermal current(Ith)	380/400V	A	200	200	275	275	315	380	450	630	700		
		A	120	160	185	225	265	330	400	500	630		
Rated operating current (Ie)	220/230V	kW	37	45	55	63	75	90	132	160	200		
		kW	55	75	90	110	132	160	220	250	355		
Rated Operating Power(Pe) AC-3	380/400V	kW	55	75	90	110	132	160	220	250	355		
		kW	80	100	110	110	165	220	300	350	450		
Mechanical Durabilities	10k times	600											
		120			80			60					
Electrical Durabilities	AC-3	10k times	120			80			60				
		Times/hour	1200			600							
Operation Frequency			1200			600							
Number of Poles			3P										
Rated Insulation Voltage(Ui)			1000										
Maximum Rated Operating Voltage(Ue)			690										
Certificate			CB, CE, SEMKO										
Coil													
Rated Control Circuit Voltage(Us)	50Hz	V	110V,127V,220V,380V										
	50/60Hz	V	48-130V, 100-250V, 250-500V (AC-DC universal)										
Allowable Control Circuit Voltage(Us)	Operation	V	AC:85%-110% (vertical installation); AC-DC: 85%-110%										
	Drop-out	V	AC: 20%-75%; AC-DC: 10%-70%										
Coil Power	Actuation	VA	500	600	800								
	Holding	VA	78	18.5	18.5								
Main Circuit terminal Wiring Capability													
Soft Wire	1 wire	mm ²	10~240										
	2 wire	mm ²	10~75										
Hard Wire	1 wire	mm ²	10-150					50-240					
	2 wire	mm ²	10-75					50-240					
Auxiliary Contact													
Conventional Thermal Current(Ith)			A 10										
Rated Operating Voltage	AC	V	380										
	DC	V	220										
Rated Control Capacity	AC-15	VA	380										
	DC-13	W	33										

HDC3 AC Contactors

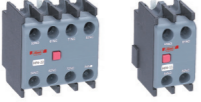
Standard: IEC60947-4







Technical Parameter													
AC Contactors	HDC3												
Contactor model	06	09	12	18	25	32	38	40	50	65	80	95	
Thermal relay													
HDR3s thermal relay 6-95 A		HDR3s-25 P16 : 0.1-0.16A P25 : 0.16-0.25A 25 : 17-25A				HDR3s-38 32 : 23-32A 38 : 30-40A			HDR3s-95 40 : 30-40A 50 : 37-50A 93 : 80-93A				
Independent installation base		HJRS1D25J				HJRS1D38J			HJRS1D93J				
Accessories													
Top auxiliary contact		2 Poles : HF4-11, HF4-20 , HF4-02 4 Poles : HF4-22, HF4-31 , HF4-13 , HF4-40 , HF4-40											
Side auxiliary contact		2 Poles : HFC6-11 , HFC6-20 , HFC6-02											
Air delayed head		Making time delay : HFT6-20 , HFT6-22 , HFT6-24 Breaking time delay : HFT6-30 , HFT6-32 , HFT6-34											
Mechanical interlock		HDC3 09-32 horizontal installation : HRF6-32 HDC3 40-95 horizontal installation : HRF6-95											
Spare coil		HX3 + Contact AF + Ue + Hz EXP : HX395M7 , HDC3 Coil 80-95A 220/230V 50/60Hz											

HDC3 AC Contactors

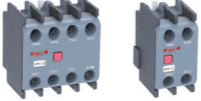
Standard: IEC60947-4



Technical Parameter											
AC Contactors	HDC3										
Contactor model HDC3	120	160	185	225	265	330	400	500	630		
Thermal relay											
HDR3s thermal relay 120-630 A		HDR3s-185 95 : 75-95A 135 : 105-135A 185 : 150-185A				HDR3s-630 200F : 145-200A 250F : 180-250A 630F : 460-630A					
Accessories											
Top auxiliary contact		2 Poles : HF4-11, HF4-20 , HF4-02 4 Poles : HF4-22, HF4-31 , HF4-13 , HF4-40 , HF4-40									
Side auxiliary contact		2 Poles : HFC4-11									
Air delayed head		Making time delay : HFT6-20 , HFT6-22 , HFT6-24 Breaking time delay : HFT6-30 , HFT6-32 , HFT6-34									
Mechanical interlock		FR4225 FR4400 FR4630									
Spare coil		EXP : HX3225M, HDC3 Coil 120-225A 220VAC 50Hz HX3225KUE7, HDC3 Coil 120-225A 100-250VAC/DC 50/60Hz									

HDC3 AC Contactors

Standard: IEC60947-4



Order Information

HDC3 06-95A

Motor power (AC-3, 380V,Kw)	Ie (A)	Auxiliary contact		Reference No
2.2	6	1	0	HDC30610*
		0	1	HDC30601*
4	9	1	1	HDC30911*
5.5	12	1	1	HDC31211*
7.5	18	1	1	HDC31811*
11	25	1	1	HDC32511*
15	32	1	1	HDC33211*
18.5	38	1	1	HDC33811*
18.5	40	1	1	HDC34011*
22	50	1	1	HDC35011*
30	65	1	1	HDC36511*
37	80	1	1	HDC38011*
45	95	1	1	HDC39511*

HDC3-N 06-95A (Reversible AC contactor)

Motor power (AC-3, 380V,Kw)	Ie (A)	Auxiliary contact		Reference No
1.5	9	1	1	HDC309N11*
2.2	12	1	1	HDC312N11*
3	18	1	1	HDC318N11*
4	25	1	1	HDC325N11*
5.5	32	1	1	HDC332N11*
5.5	38	1	1	HDC338N11*

HDC3 120-630A

Motor power (AC-3, 380V,Kw)	Ie (A)	Auxiliary contact		Reference No
55	120	2	2	HDC312022*
75	160	2	2	HDC316022*
90	185	2	2	HDC318522*
110	225	2	2	HDC322522*
132	265	2	2	HDC326522*
160	330	2	2	HDC333022*
220	400	2	2	HDC340022*
250	500	2	2	HDC350022*
355	630	2	2	HDC363022*

HDC3 AC Contactors

Standard: IEC60947-4



HDC3 6-95A & 120-630A Contactor Accessories

Transparent cover

Contactor Type	Reference
HDC3-6~38A/HDZ3	HPCs38
HDC3-40~65A	HPCs65
HDC3-80~95A	HPCs95

Auxiliary contact

Installation position	Pole	Auxiliary Contact NO	NC	Contact point layout	Reference	
Top	2	0	2		HF4 02	
		1	1		HF4 11	
		2	0		HF4 20	
	4	0	4		HF4 04	
		1	3		HF4 13	
		2	2		HF4 22	
		3	1		HF4 31	
	Side	2	0	2		HFC6 02
			1	1		HFC6 11
		4	0	4		HFC6 20



Air Delayed Head

Installation Position	Delay type	Wiring diagram	Delay range	Reference
Top	Making time-delay		0.1-3s	HFT6 20
			0.1-30s	HFT6 22
			10-180s	HFT6 24
	Breaking time-delay		0.1-3s	HFT6 30
			0.1-30s	HFT6 32
			10-180s	HFT6 34



Mechanical Interlock

Horizontal installation		
Interlock method	Contact type	Reference
Mechanical interlock with electrical interlock	HDC3-9~32	HFR6 32 H
	HDC3-40~95	HFR6 95 H



MOTOR MANAGEMENT

HDC3 AC Contactors

Standard: IEC60947-4



Spare Coil

HX3 9-95A

Contactor	Spear coil	Coil voltage	Coil Frequency
HDC3 06A	HX306*	B : 24V C : 36V E : 48V F : 110V S : 127V M : 220/230V; U : 240V; Q : 380/400V; L : 415V; X : 440V	5 : 50Hz 7 : 50/60Hz
HDC3 09-18A	HX31811*		
HDC3 25-38A	HX33811*		
HDC3 40-65A	HX365*		
HDC3 80-95A	HX395*		



HX3 185-630A

Contactor	Spear coil	Coil voltage	Coil Frequency
HDC3 120A	HX3120*	F : 110V; S : 127V; M : 220V; Q : 380V; EHE7 : 48~130V KUE7 : 100~250V URE7 : 250~500V	Default : 50Hz 7 : 50/60Hz
HDC3 160A	HX3160*		
HDC3 185A	HX3185*		
HDC3 225A	HX3225*		
HDC3 265A	HX3265*		
HDC3 330A	HX3330*		
HDC3 400A	HX3400*		
HDC3 500A	HX3500*		
HDC3 630A	HX3630*		



Note 1: "*" is relavent coil voltakge & frequency

2: HDC3185-630 50Hz coil only available for HDC3 185-225A

MOTOR MANAGEMENT

HDC3 AC Contactors

Standard: IEC60947-4



Motor Power

Motor power of HDC3 (AC-4)

Product	Ith(A)	AC-4			
		Ie(A)		Pe(kW)	
		380/400V	660/690	380/400V	660/690
HDC3-06	25	2.6	1	1.1	0.75
HDC3-09	25	3.5	1.5	1.5	1.1
HDC3-12	25	5	2	2.2	1.5
HDC3-18	32	7.7	3.8	3.3	3
HDC3-25	40	8.5	4.4	4	3.7
HDC3-32	50	12	7.5	5.4	5.5
HDC3-38	50	14	8.9	5.5	6
HDC3-40	60	18.5	9	7.5	7.5
HDC3-50	80	24	12	11	10
HDC3-65	80	28	14	15	11
HDC3-80	125	37	17.3	18.5	15
HDC3-95	125	44	21.3	22	18.5

Motor power of HDC3 (Reversible AC contactor)

Product	Ith(A)	AC-4			
		Ie(A)		Pe(kW)	
		380/400V	660/690	380/400V	660/690
HDC3-09	25	3.5	1.5	1.5	1.1
HDC3-12	25	5	2	2.2	1.5
HDC3-18	32	7.7	3.8	3.3	3
HDC3-25	40	8.5	4.4	4	3.7
HDC3-32	50	12	7.5	5.4	5.5
HDC3-38	50	14	8.9	5.5	6
HDC3-40	60	18.5	9	7.5	7.5
HDC3-50	80	24	12	11	10
HDC3-65	80	28	14	15	11
HDC3-80	125	37	17.3	18.5	15
HDC3-95	125	44	21.3	22	18.5

HDC3 AC Contactors

Standard: IEC60947-4



Motor Power

Motor power of HDC3 (AC-4)

Product	Ith(A)	AC-4						Intermittent work; rated operating frequency at 40% load factor
		Ie(A)			Pe(kW)			
		220/230V	380/400V	660/690V	220/230V	380/400V	660/690V	
HDC3-120	200	54	54	48	18.5	30	50	220/380V : 120times/h 660V : 30times/h
HDC3-160		68	68	57	22	37	55	
HDC3-185	275	81	81	65	30	45	63	
HDC3-225		96	96	85	30	55	80	
HDC3-265	315	117	117	105	37	63	100	
HDC3-330	380	125	125	115	40	75	110	
HDC3-400	450	150	150	135	45	90	132	
HDC3-500	630	175	175	150	55	100	150	
HDC3-630	700	225	225	200	75	110	185	

Motor power of HDC3 (Reversible AC contactor)

Reversible Product (Horizontal installation)	Ith(A)	Ie(A) AC-3		Pe(kW) AC-3	
		380V	660V	380V	660V
HDC3-120N	200	120	86	55	80
HDC3-160N		160	107	75	100
HDC3-185N	275	185	107	90	110
HDC3-225N		225	118	110	110
HDC3-265N	315	265	170	132	165
HDC3-330N	380	330	225	160	220
HDC3-400N	450	400	303	220	300
HDC3-500N	630	500	353	250	350
HDC3-630N	700	630	400	355	450

HDC3 AC Contactors

Standard: IEC60947-4



Star-Delta Stater

Contactor (HDC3-09~95)

Max. Starting Frequency: 30 times/h; Max. Starting Time: 30s						
Class AC-3 50Hz 3-Phase Electromotor Delta Connection		Contactor			Thermal Relay	
		Straight Connection	Delta Connection	Star Connection		
		KM2	KM3	KM1		
In (A)	IrD (A)	Type	Type	Type	Type	Setting Range (A)
3.5	2	HDC3-09	HDC3-09	HDC3-09	HDR3s-25	1.8~2.5
5	3	HDC3-09	HDC3-09	HDC3-09	HDR3s-25	2.5~3.6
6.6	4	HDC3-09	HDC3-09	HDC3-09	HDR3s-25	3.5~4.8
8.5	5	HDC3-09	HDC3-09	HDC3-09	HDR3s-25	4.5~6.3
11.5	6	HDC3-09	HDC3-09	HDC3-09	HDR3s-25	5~7
15.5	9	HDC3-12	HDC3-12	HDC3-09	HDR3s-25	9~12
18.5	11	HDC3-18	HDC3-18	HDC3-12	HDR3s-25	11~15
22	13	HDC3-18	HDC3-18	HDC3-12	HDR3s-25	11~15
30	16	HDC3-25	HDC3-25	HDC3-18	HDR3s-25	14~18
37	22	HDC3-25	HDC3-25	HDC3-18	HDR3s-25	18~25
44	26	HDC3-32	HDC3-32	HDC3-25	HDR3s-38	23~32
60	35	HDC3-40	HDC3-40	HDC3-32	HDR3s-38	30~40
72	40	HDC3-50	HDC3-50	HDC3-40	HDR3s-95	37~50
85	47	HDC3-65	HDC3-65	HDC3-50	HDR3s-95	37~50
105	58	HDC3-80	HDC3-80	HDC3-65	HDR3s-95	55~70
138	78	HDC3-95	HDC3-95	HDC3-80	HDR3s-95	63~80

HDC3 AC Contactors

Standard: IEC60947-4



Normal Installation And Operation Conditions

Standards

- ◆ EC 60947-1 General rules
- ◆ IEC 60947-4-1 Contactors
- ◆ IEC 60947-5-1 Relays

Pollution class

- ◆ Class 3

Ambient temperature

- ◆ In normal operation, the ambient temperature range is between -5°C and +40°C, but average value in 24h is no more than +35°C;
- ◆ Storage temperature: -25°C ~ +55°C; a short time (24h) is allowed with maximum +70°C

Altitude

- ◆ Altitude at normal installation position does not exceed 2000m.

Humidity

- ◆ The atmospheric relative humidity does not exceed 50% when the highest ambient temperature is +40°C. It is allowed to have a relative higher humidity under lower temperature, e.g. up to 90% at +20°C.
- ◆ For occasional dew due to the temperature change, preventive measures shall be taken.

Product protection grade

- ◆ IP20

Installation Conditions

- ◆ Installation type: III
- ◆ Installation position: should be installed in the absence of a significant shock and vibration place. The installation site shall be vertical, and inclination at all directions shall not exceed ±5°. When the coil control voltage is not lower than 85%Us, the inclination should be no more than ±30°.

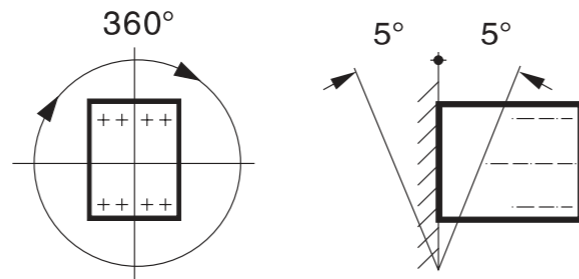

Temperature Derating

Ambient temperature(°C)	55°C	60°C	65°C	70°C
Correction factor	1	0.93	0.875	0.75

Altitude Derating

Altitude(m)	2000	3000	4000
Rated impulse withstand voltage coefficient	1	0.88	0.78
Rated working current coefficient	1	0.92	0.9

HDC3 AC Contactors

Standard: IEC60947-4



Wiring Diagram

HDC3 06 with 1NO or 1NC Auxiliary Contact

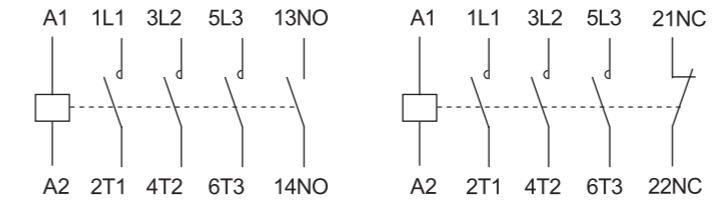

HDC3 09~95 with 1NO+1NC Auxiliary Contact

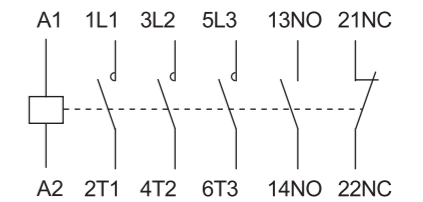

HDC3 185~630 with 2NO+2NC Auxiliary Contact

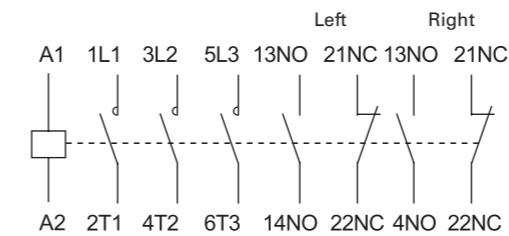

DOL Control

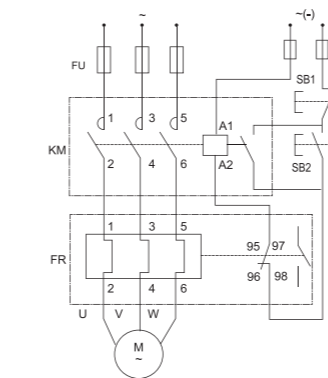

Reversible Control

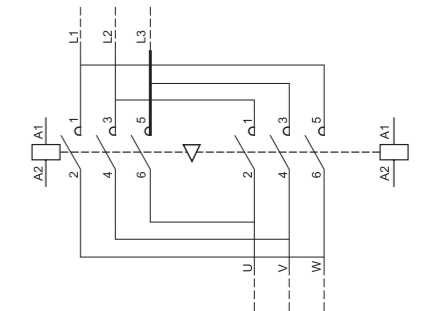

Star-Delta Control

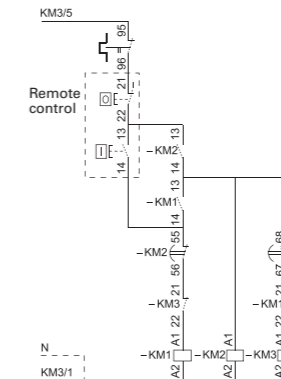
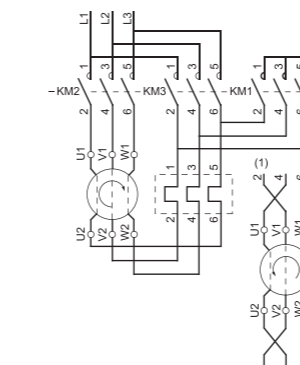

HDC3 AC Contactors

Standard: IEC60947-4



Installation Dimensions

HDC3 06-38A

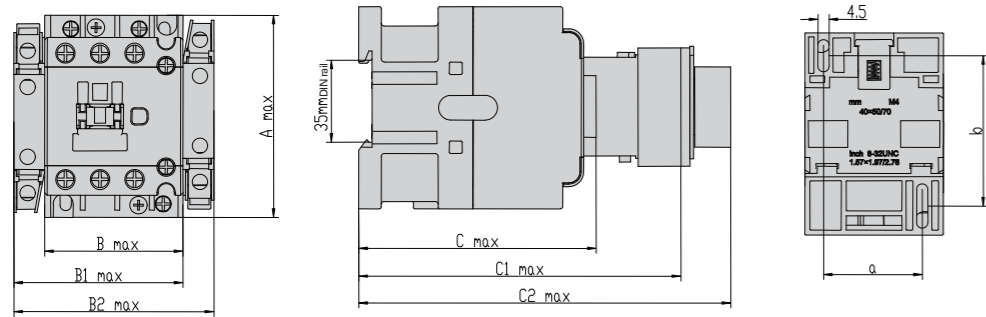

HDC3-40-95A

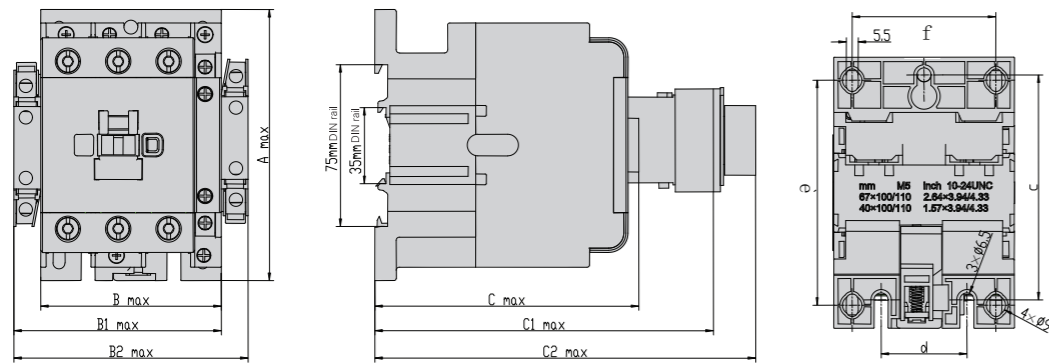

Overall Dimension of HDC3 06-95A AC Contactor

Model	Amax	Bmax	B1max	B2max	Cmax	C1max	C2max
HDC3-06	74.5	45.5	-	-	75	107	132
HDC3-09, 12, 18	74.5	45.5	58	71	82.5	114.5	139.5
	74.5	45.5	58	71	85.5	117.5	142.5
HDC3-25, 32, 38	83	56.5	69	82	97	129	154
HDC3-40, 50, 65	127.5	74.5	88	101	117	148.5	173.5
HDC3-80,95	127.5	85.5	99	112	125.5	157	182

Plate Installation Dimension of HDC3 06-95A AC Contactor

Model	a	b	c	d	e	f
HDC3-06	35	50/60	-	-	-	-
HDC3-09, 12, 18	35	50/60	-	-	-	-
HDC3-25, 32, 38	40	50/70	-	-	-	-
HDC3-40, 50, 65	-	-	105	40	100/110	59
HDC3-80,95	-	-	105	40	100/110	67

HDC3 AC Contactors

Standard: IEC60947-4



Installation Dimensions

HDC3-N 09-38A

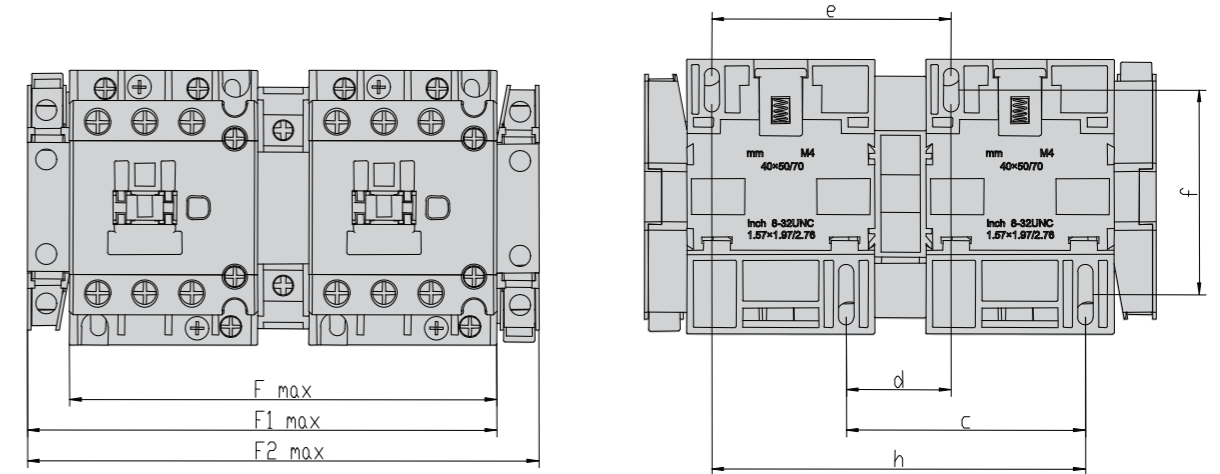

HDC3-N 40-95A

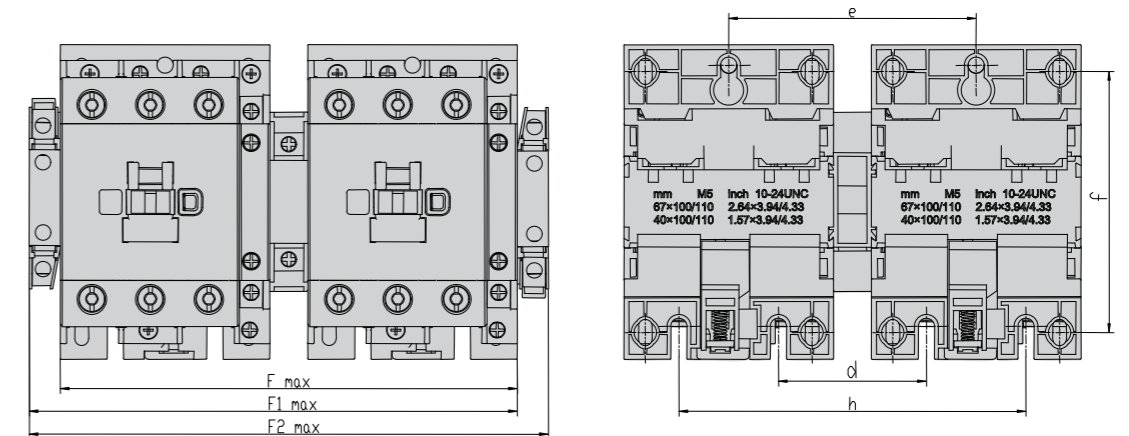

Overall Dimension of HDC3-N 09-95A Directional AC Contactor

Model	Fmax	F1max	F2max	c	d	e	f	h
HDC3-09N, 12N, 18N	107	120	131	60	25	60	50/60	95
HDC3-25N, 32N, 38N	129	142	153	71	31.5	71	50/60	111.5
HDC3-40N, 50N, 65N	163	180	193	-	50	90	100/110	130
HDC3-80N,95N	186	202	215	-	60	100	100/110	140

HDC3 AC Contactors

Standard: IEC60947-4



Installation Dimensions

HDC3 185-630

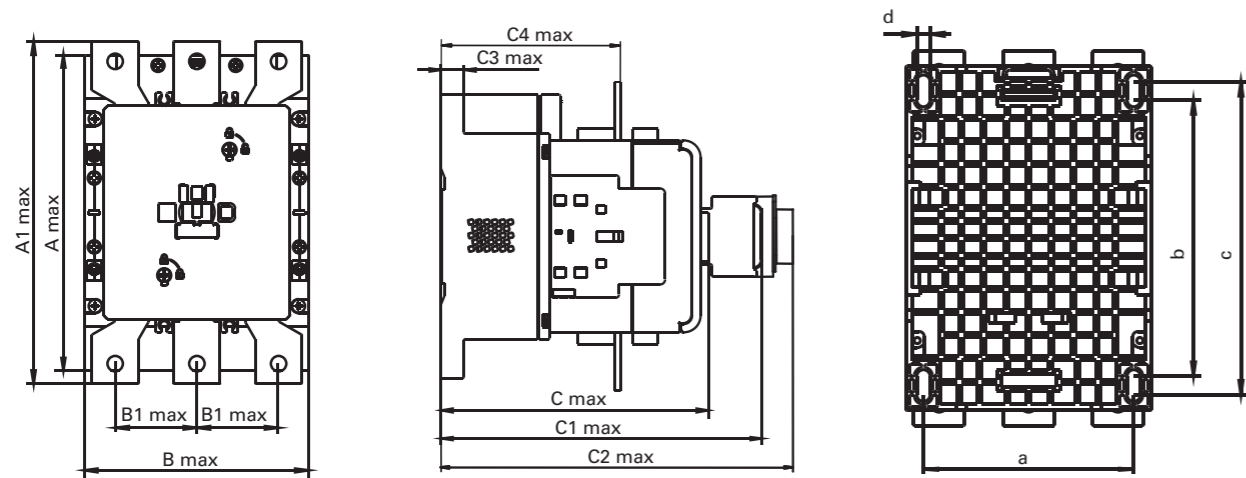

Model	Amax	A1max	Bmax	B1max	Cmax	C1max	C2max	C3max	C4max	a	b	c	d
HDC3-120	170	185	120	45	161	193	198	13.5	108.5	104.5	136.5	154.5	6.5
HDC3-160	170	185	120	45	161	193	198	13.5	108.5	104.5	136.5	154.5	6.5
HDC3-185	170	185	120	45	161	193	198	13.5	108.5	104.5	136.5	154.5	6.5
HDC3-225	170	185	120	45	161	193	198	13.5	108.5	104.5	136.5	154.5	6.5
HDC3-265	211.5	201.5	154	53.5	208	240	245	17	142	129.5	174.7	189.5	9
HDC3-330	211.5	201.5	154	53.5	208	240	245	17	142	129.5	174.7	189.5	9
HDC3-400	211.5	201.5	154	53.5	208	240	245	17	142	129.5	174.7	189.5	9
HDC3-500	216.5	138.5	170.5	62	231.5	263.5	268.5	18	158	131.5	181.5	191.5	10
HDC3-630	216.5	138.5	170.5	62	231.5	263.5	268.5	18	158	131.5	181.5	191.5	10

HDC3 AC Contactors

Standard: IEC60947-4



Installation Dimensions

HDC3 185-630 (Reversible AC contactor)

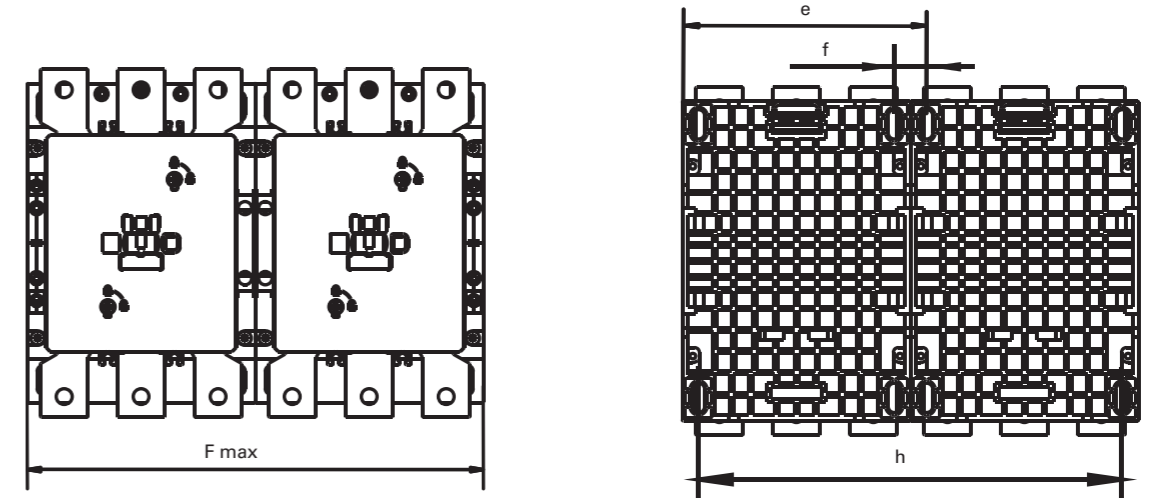

Model	Fmax	e	f	h
HDC3-120N	241.5	130	18.5	224.5
HDC3-160N	241.5	130	18.5	224.5
HDC3-185N	241.5	130	18.5	224.5
HDC3-225N	241.5	130	18.5	224.5
HDC3-265N	309.5	168.5	27.5	270
HDC3-330N	309.5	168.5	27.5	270
HDC3-400N	309.5	168.5	27.5	270
HDC3-500N	339.5	190	40.5	281
HDC3-630N	339.5	190	40.5	281

MOTOR MANAGEMENT

HDC3S AC Contactors

Standard: I



Range Presentation

HDC3S is Himel 3 series range of contactors designed for Motor Control AC3 applications form 120 to 400A.

HDC3S contactors are applicable to AC power systems 50Hz or 60Hz with rated operating voltage up to 690V.

HDC3S contactors can be combined with HDR3s thermal overload relays to form magnetic motor starters up to 630A.

HDC3S contactors can use all Himel 3 series accessories expect Spare Coil

Selection Code

Range name	Current specification	Reversible	Auxiliary contact	Coil voltage	Coil frequency
HDC3S	120			F	7
120-400A	120:120A 160:160A 185:185A 225:225A 265:265A 330:330A 400:400A	Default: AC Contact	Default: 2NO+2NC	F:AC/DC 110V S:AC/DC 127V M:AC/DC 220/230V Q:AC/DC 380/400V	7:50/60Hz

Overview of Accessories

HDC3 120-630A Accessories

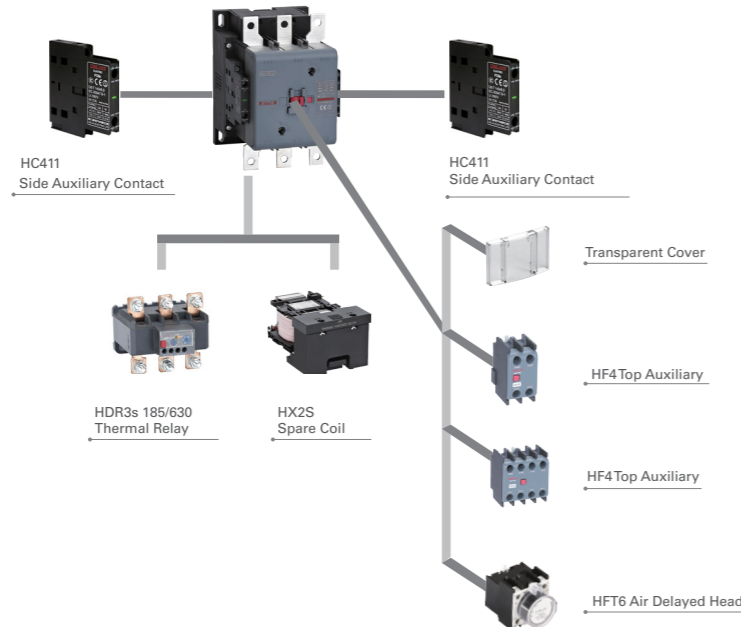

MOTOR MANAGEMENT

HDC3S AC Contactors

Standard: I



specification





Main technical parameter								
AC Contactor	HDC3S							
Contactor model	120	160	185	225	265	330	400	
Number of Poles	3P							
Rated Insulation Voltage(Ui)	V	690						
Maximum Rated Operating Voltage(Ue)	V	AC220/230V;380/400V;660/690V						
Conversional thermal current(Ith), AC-1	A	200	200	275	275	315	380	450
Rated operating current (Ie)	AC-3;220/230V(A)	120	160	185	225	265	330	400
	AC-3;380/400V(A)	120	160	185	225	265	330	400
	AC-3;660/690V(A)	86	107	107	118	170	225	303
Rated Operating Power(Pe)	AC-3;220/230V(kW)	37	45	55	63	75	90	132
	AC-3;380/400V(kW)	55	75	90	110	132	160	220
	AC-3;660/690V(kW)	80	100	110	110	165	220	300
Mechanical Durabilities	10k times	1000	1000	1000	1000	600	600	600
Electrical Durabilities,AC-3	10k times	120	120	110	110	90	90	90
Operation Frequency,AC-3	Times/hour	1200	1200	600	600	600	600	600
Main Circuit terminal Wiring Capability								
Soft Wire	1 wire(mm ²)	10-150	10-150	10-150	10-150	10-150	10-150	10-150
	2 wire(mm ²)	10-75	10-75	10-75	10-75	10-75	10-75	10-75
Hard Wire	1 wire(mm ²)	10-150	10-150	10-150	10-150	10-150	50-240	50-240
	2 wire(mm ²)	10-75	10-75	10-75	10-75	10-75	50-240	50-240
Main loop tightening torque	N·m	12	12	12	12	14	14	14
Coil								
Rated Control Circuit Voltage(Us)	50/60Hz	AC/DC:110V、127V、220/230V、380/400V						
Allowable Control Circuit Voltage(Us)	Operation	85%-110% (vertical installation)						
	Drop-out	20%~60%Us						
Coil Power	Actuation(VA)	1500	1500	1500	1500	2800	2800	2800
	Holding(VA)	15	15	15	15	25	25	25
Auxiliary Contact								
Number of contacts		2NO+2NC						
Conventional Thermal Current(Ith)	A	10						
Rated Operating Voltage(Ue)	AC	380V						
	DC	220V						
Rated Control Capacity	AC-15	360VA						
	DC-13	33W						
Certificate		CE/CB						

MOTOR MANAGEMENT

HDC3S AC Contactors

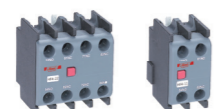
Standard:



Technical Parameter									
AC Contactors	HDC3S								
Contactors model HDC3	120	160	185	225	265	330	400	500	630
Thermal relay									
HDR3s thermal relay 120-630 A	 <p>HDR3s-185 95 : 75-95A 135 : 105-135A 185 : 150-185A</p>			<p>HDR3s-630 200F : 145-200A 250F : 180-250A 630F : 460-630A</p>					
Accessories									
Top auxiliary contact	 <p>2 Poles : HF4-11, HF4-20, HF4-02 4 Poles : HF4-22, HF4-31, HF4-13, HF4-40, HF4-40</p>								
Side auxiliary contact	 <p>Side auxiliary contact HC411</p>								
Air delayed head	 <p>Making time delay : HFT6-20, HFT6-22, HFT6-24 Breaking time delay : HFT6-30, HFT6-32, HFT6-34</p>								
Mechanical interlock	 <p>FR4225 FR4400 FR4630</p>								
Spare coil	 <p>HX2S225M7 :Spare Coil For HDC3S 120-225 A AC/DC 220/230V 50/60Hz</p>								

MOTOR MANAGEMENT

HDC3S AC Contactors

Standard:



Motor Power

Motor power of HDC3 (AC-4)

Product	Ith(A)	AC-4						Intermittent work; rated operating frequency at 40% load factor
		Ie(A)			Pe(kW)			
		220/230V	380/400V	660/690V	220/230V	380/400V	660/690V	AC-4
HDC3S-120	200	54	54	48	18.5	30	50	220/380V : 120times/h 660V : 30times/h
HDC3S-160	200	68	68	57	22	37	55	
HDC3S-185	275	81	81	65	30	45	63	
HDC3S-225	275	96	96	85	30	55	80	
HDC3S-265	315	117	117	105	37	63	100	
HDC3S-330	380	125	125	115	40	75	110	
HDC3S-400	450	150	150	135	45	90	132	

Normal Installation And Operation Conditions

Standards

- ◆ GB/T 14048.4
- ◆ IEC60947-4-1

Pollution class

- ◆ Class 3

Ambient temperature

- ◆ In normal operation, the ambient temperature range is between -5°C and +40°C, but average value in 24h is no more than +35°C;
- ◆ Storage temperature: -25°C ~ +55°C; a short time (24h) is allowed with maximum +70°C

Altitude

- ◆ Altitude at normal installation position does not exceed 2000m.

Humidity

- ◆ The atmospheric relative humidity does not exceed 50% when the highest ambient temperature is +40°C. It is allowed to have a relative higher humidity under lower temperature, e.g. up to 90% at +20°C.

Product protection grade

- ◆ IP20

Installation Conditions

- ◆ Installation type: III
- ◆ Installation position: should be installed in the absence of a significant shock and vibration place. The installation site shall be vertical, and inclination at all directions shall not exceed ±5°. When the coil control voltage is not lower than 85%Us, the inclination should be no more than ±30°.

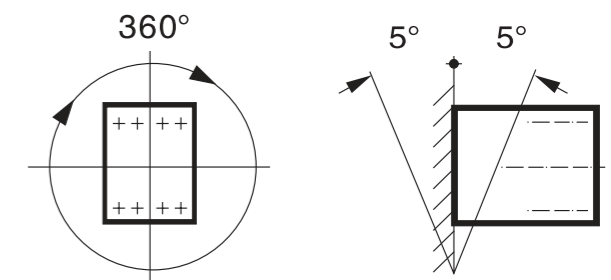

MOTOR MANAGEMENT

HDC3S AC Contactors

Standard:



Temperature Derating				
Ambient temperature(°C)	55°C	60°C	65°C	70°C
Correction factor	1	0.93	0.875	0.75

Altitude Derating			
Altitude(m)	2000	3000	4000
Rated impulse withstand voltage coefficient	1	0.88	0.78
Rated working current coefficient	1	0.92	0.9

Wiring Diagram

HDC3S 120-400A with 2NO+2NC Auxiliary Contact

Star-Delta Control

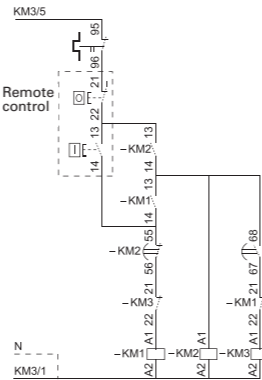
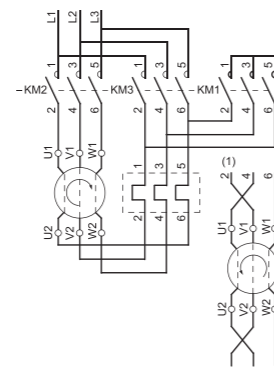
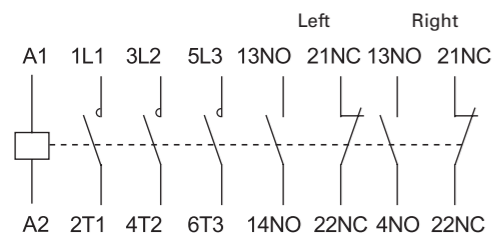

DOL Control

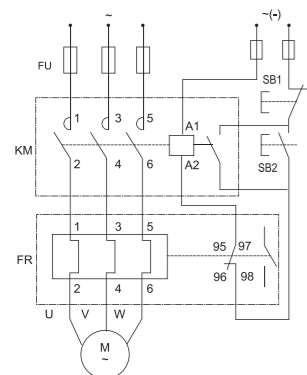

Reversible Control

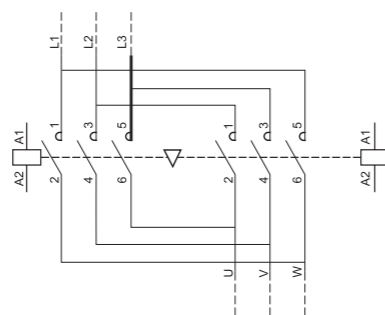

MOTOR MANAGEMENT

HDC3S AC Contactors

Standard:



HDC3S-120~400A

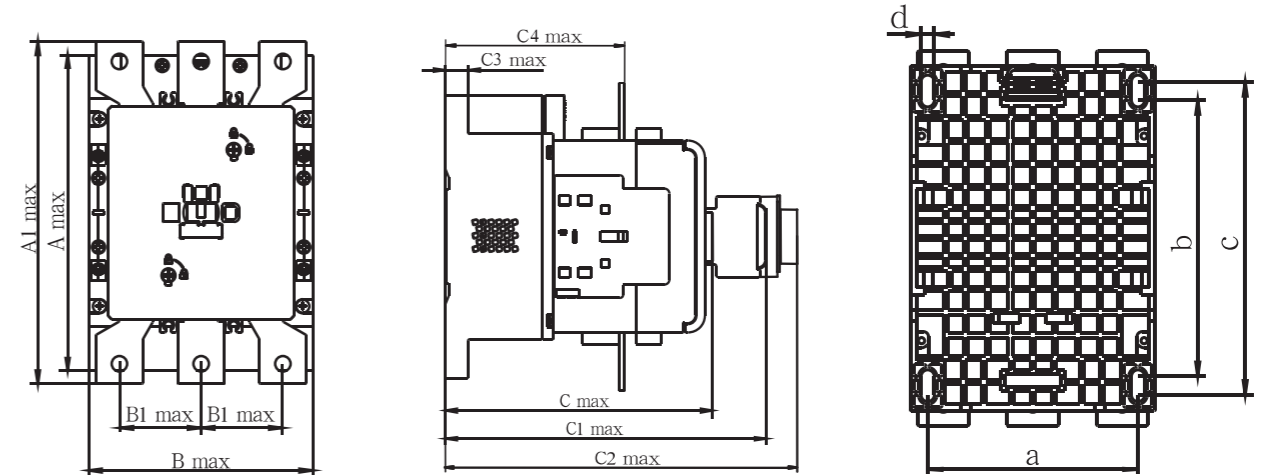

Contactor	Amax	A1max	Bmax	B1max	Cmax	C1max	C2max	C3max	C4max	a	b	c	d
HDC3S-120	168.5	182.5	120	40.5	161	193	198	13.5	109	103	135	153	6.5
HDC3S-160	168.5	182.5	120	40.5	161	193	198	13.5	109	103	135	153	6.5
HDC3S-185	168.5	182.5	120	40.5	161	193	198	13.5	109	103	135	153	6.5
HDC3S-225	168.5	182.5	120	40.5	161	193	198	13.5	109	103	135	153	6.5
HDC3S-265	210	200	154	52.5	208	240	245	17	142	128	173	188	9
HDC3S-330	210	200	154	52.5	208	240	245	17	142	128	173	188	9
HDC3S-400	210	200	154	52.5	208	240	245	17	142	128	173	188	9

MOTOR MANAGEMENT

HDR3s Thermal Overload Relays

Standard: IEC60947-4



Range Presentation

HDR3s is Himel 3 series range of thermal overload relays designed to provide protection against overload, phase loss and current imbalance.

HDR3s thermal overload relays can be combined with HDC3 contactors into motor starter.

Features

- ◆ Frame Rating Current: 25, 38, 93, 185, 630A
- ◆ Setting Current: 0.1-630 A

Online Content



HDR3s

Selection Code

Range name	Frame size	Setting currents
HDR3s	25	P16
	25: 25A	P16: 0.1- 0.16A 25: 17 - 25A
	38: 38A	32: 25 - 32A 40: 32 - 38A
	93: 93A	10: 7.0- 10A 93: 80 - 93A
	185: 185A	65: 48-65A 185: 150-185A
	630: 630A	200F: 145-200A 630F: 460-630A

Technical Parameters

Thermal overload relay		HDR3s			
Main technical parameters		-5°C~+40°C			
Temperature compensation					
HDR3s Thermal Relay	25	38	93	185	630
Trip level	10A		10		10A
Rated insulation voltage(Ui) V	660V			690V	
Base	HJRS1D25J	HJRS1D36J	HJRS1D93J	-	-
Certificate	CB, CE, SEMKO				
Product features					
Overload protection	Yes				
Phase-failure protection	Yes				
Manual reset	Yes				
Automatic reset	Yes				
Stop button	Yes				
Test button	Yes				
Trip indication	Yes				
Tolerance on slope in any direction	±5°				
Auxiliary circuit 1NO+1NC					
Utilization category	AC-15			DC-13	
Rated frequency Hz	50/60		50/60		
Rated insulation voltage (Ui) V	500		500		500
Rated operating voltage (Ue) V	230		400		230
Rated operating current Ie A	1.57		0.90		0.14
Conventional thermal current Ith A	5		5		5
Wiring	1mm ²				

MOTOR MANAGEMENT

HDR3s Thermal Overload Relays

Standard: IEC60947-4



Order Information

Frame Current (A)	Setting Current(A) code	Recommended HRT16	Recommended Contactor	Reference		
25	0.1-0.16	P16	4	HDR3s25P16		
	0.16-0.25	P25	4	HDR3s25P25		
	0.25-0.4	P4	4	HDR3s25P4		
	0.4-0.63	P63	4	HDR3s25P63		
	0.63-1	1	4	HDR3s251		
	1-1.6	1P6	4	HDR3s251P6		
	1.6-2.5	2P5	6	HDR3s252P5		
	2.5-4	4	10	HDR3s254		
	4-6	6	16	HDR3s256		
	5.5-8	8	20	HDR3s258		
	7-10	10	20	HDR3s2510		
	9-13	13	25	HDC3 12-38 HJX2 4P 12-40	HDR3s2513	
12-18	18	35	HDC3 18-38 HJX2 4P 25-40	HDR3s2518		
17-25	25	50	HDC3 25-38 HJX2 4P 25-40	HDR3s2525		
38	23-32	32	63	HDC3 32-38 HJX2 4P 25-40	HDR3s3832	
	30-40	40	80	HDC3 32-38 HJX2 4P 40	HDR3s3840	
93	7.0-10	10	20	HDC3 40-95	HDR3s9310	
	9.0-13	13	25		HDR3s9313	
	12-18	18	35		HDR3s9318	
	17-25	25	50		HDR3s9325	
	23-32	32	63		HDR3s9332	
	30-40	40	80		HDR3s9340	
	37-50	50	100		HDC3 50-95 HJX24P 50-95	HDR3s9350
	48-65	65	100		HDR3s9365	
	55-70	70	125		HDC3 65-95 HJX2 4P 65-95	HDR3s9370
	63-80	80	125		HDC3 80-95 HJX2 4P 80-95	HDR3s9380
80-93	93	160	HDC3 95 HJX2 4P 80-95	HDR3s9393		



HDR3s Thermal Overload Relays

Standard: IEC60947-4



Frame Current (A)	Setting Current(A) code	Recommended HRT16	Recommended Contactor	Reference
185	48-65	65	100	HDR3s18565
	55-70	70	100	HDR3s18570
	63-80	80	100	HDR3s18580
	75-95	95	125	HDR3s18595
	90-115	115	200	HDR3s185115
	105-135	135	200	HDR3s185135
	120-150	150	200	HDR3s185150
	130-160	160	250	HDR3s185160
630	150-185	185	250	HDR3s185185
	145-200	200F	400	HDR3s630200F
	180-250	250F	400	HDR3s630250F
	230-320	320F	500	HDR3s630320F
	290-400	400F	630	HDR3s630400F
	350-480	480F	800	HDR3s630480F
	460-630	630F	800	HDR3s630630F



Base	
Adapted contactor	Reference No
HDR3s-25	HJRS1D25J
HDR3s-38	HJRS1D36J
HDR3s-93	HJRS1D93J

HDR3s Thermal Overload Relays

Standard: IEC60947-4



Overview

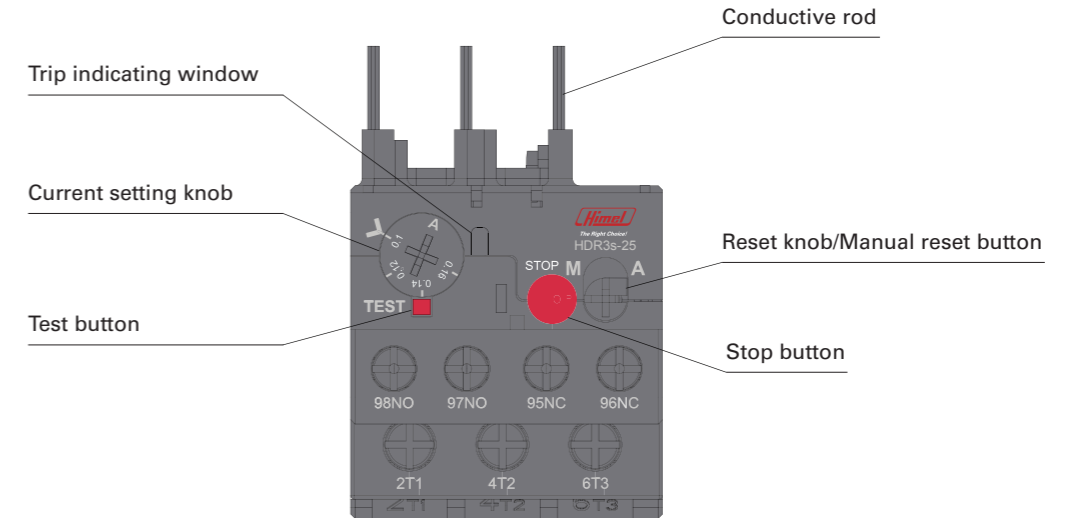

1, Trip indicating window

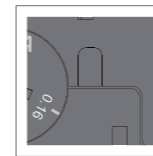

When the thermal overload relay tripped, the trip indicating window will show orange color, which means "tripped"

2, Current setting knob

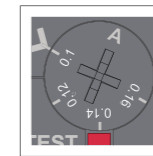

Set the adjusting current for the electric motor

3, Test button

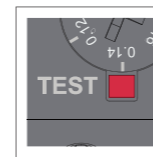

Simulate "trip"(make NO, NC contacts act) to check the control circuit

4, Reset knob/Manual reset button

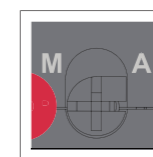

Reset knob:
When the wedge points to M: Manual reset
When the wedge points to A: Automatic reset
Manual reset button:
When the thermal overload relay tripped(indicating window shows orange color), push this button to reset the relay.

5, Stop button

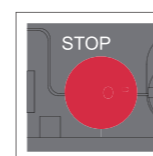

Make the NC contacts act, but not affect the NO contacts. When push STOP button, the control circuit will be open, and motor stops working.

6, Conductive rod

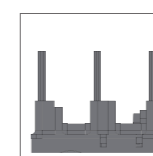

Can be inserted into main circuit terminal of the contactor. The square rod increase the contact surface, and make the wire connection more tight.

HDR3s Thermal Overload Relays

Standard: IEC60947-4



Tripping Characteristics

No.	Multiples of Current Setting	Tripping Time		Initial Condition	Reference Ambient Air Temperature
		Trip class 10A	Trip class 10		
Limits of operation of time-delay overload relays when energized on all poles					
1	1.05	Non-tripping within 2h	Non-tripping within 2h	Cold State	+20°C
2	1.2	Tripping within 2h	Tripping within 2h	After No.1 Test (Thermal Equilibrium)	
3	1.5	<2min	<4min	After No.1 Test (Thermal Equilibrium)	
4	7.2	2s<Tp≤10s	4s<Tp≤10s	Cold State	+20°C
Limits of operation of three-pole thermal overload relays when energized on two poles only					
When the value of current flowing in two poles and the third pole de-energized					
1	1.0 0.9	Non-tripping within 2h	Non-tripping within 2h	Cold State	+20°C
2	1.15 0	Tripping within 2h	Tripping within 2h	After No.1 Test (Thermal Equilibrium)	

Tripping Characteristics

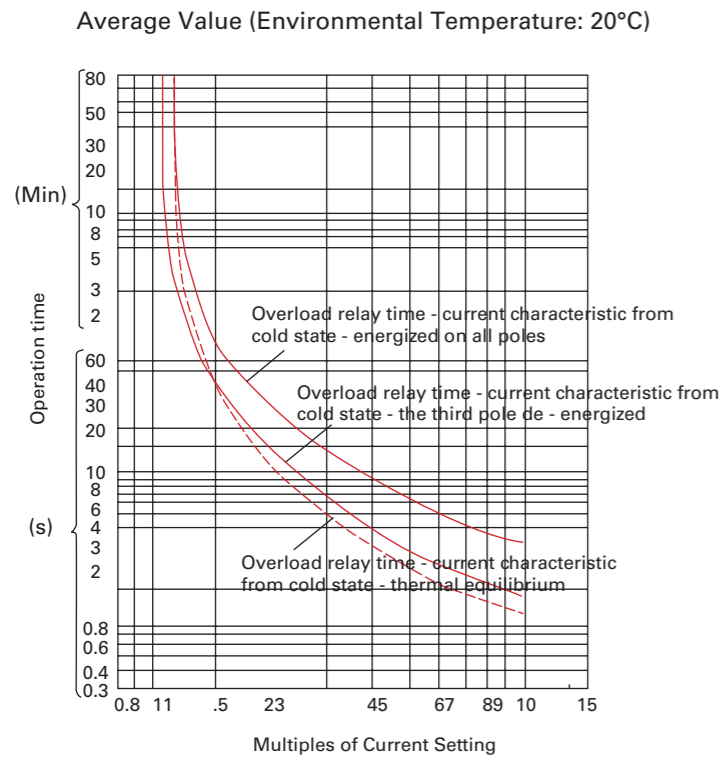

Wiring Diagram

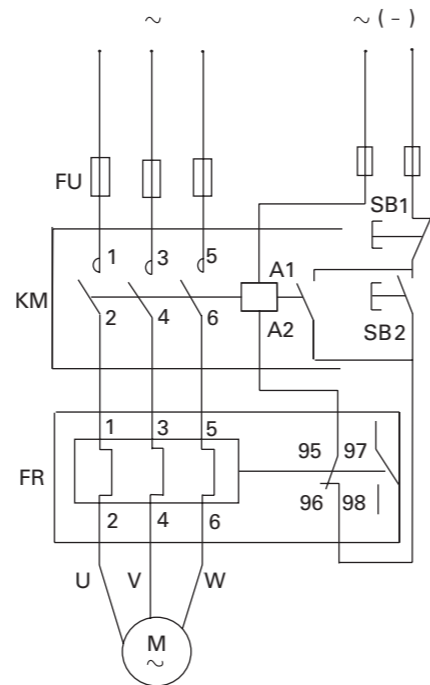

HDR3s Thermal Overload Relays

Standard: IEC60947-4



Overall Dimension

Overall Dimensional Drawing of HDR3s-25/Z

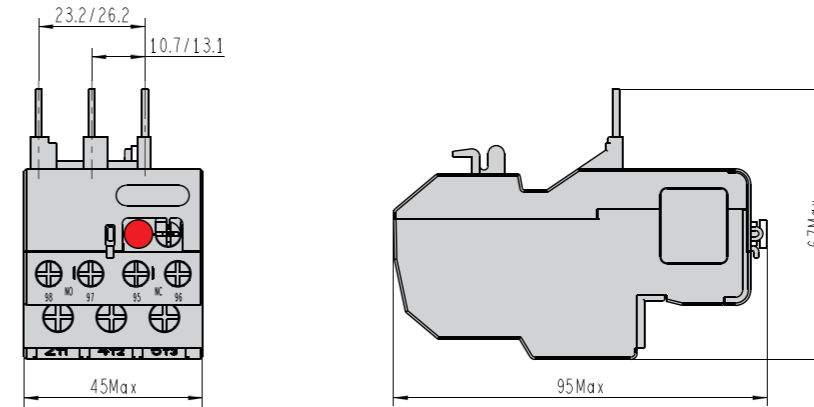

Overall Dimensional Drawing of HDR3s-38/Z

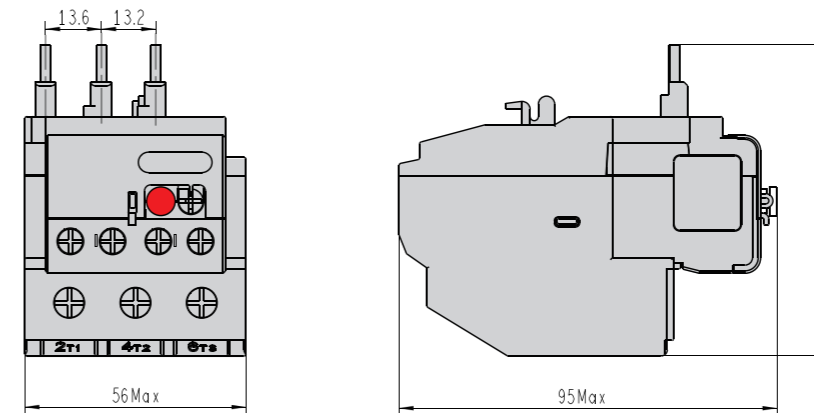

Overall Dimensional Drawing of HDR3s-93/Z

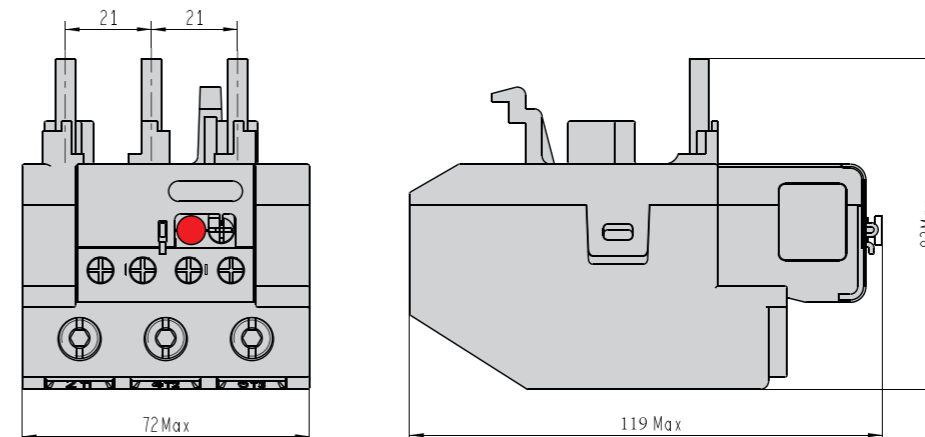

HDR3s Thermal Overload Relays

Standard: IEC60947-4



Installation Instruction

HDR3s 185 Assembly Installation

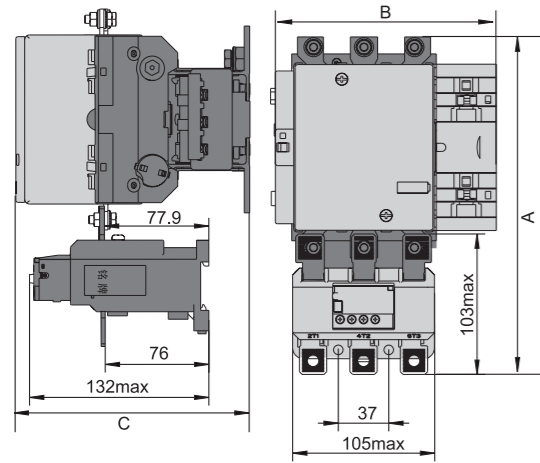

HDR3s 185 Independent Installation

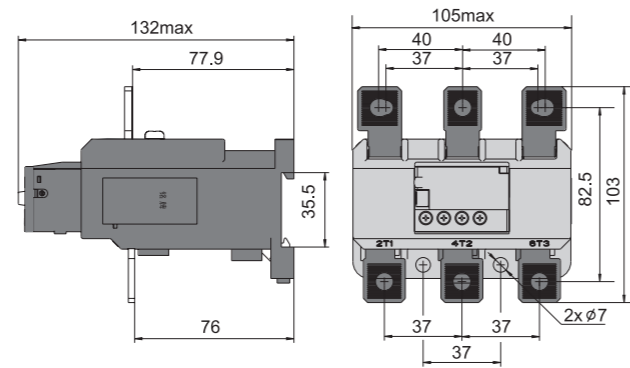

	HDC3-120	HDC3-160	HDC3-185
A	248	253	257
B	167	167	171
C	172	172	183

HDR3s 630 Independent Installation

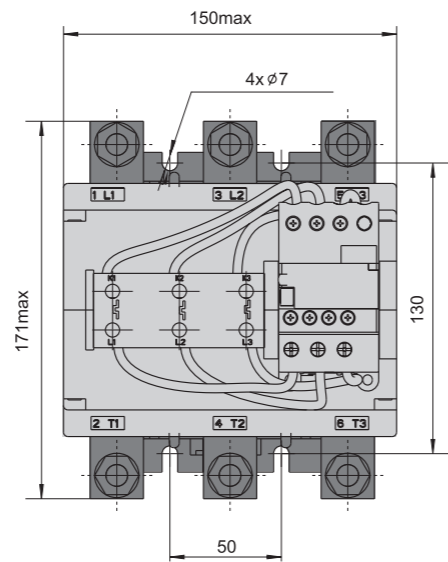
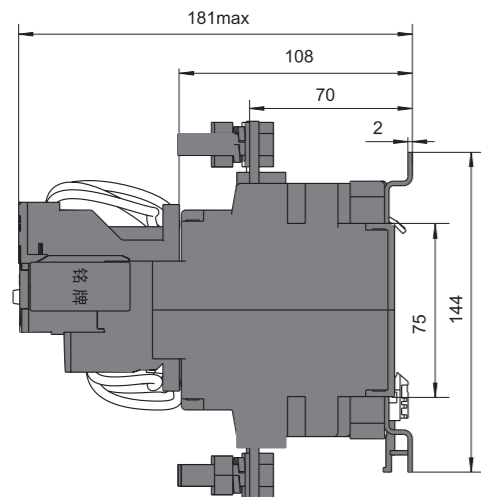

HDR3s Thermal Overload Relays

Standard: IEC60947-4



Assembly With Contactor

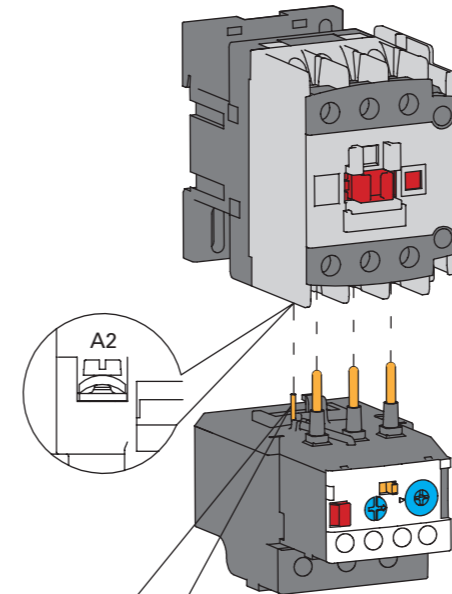

This wire is the coil rapid wiring terminal which can be used as the assembly with the contactor. When these two are completely connected, the screw in A2 contact point of the contactor coil should be tightened.

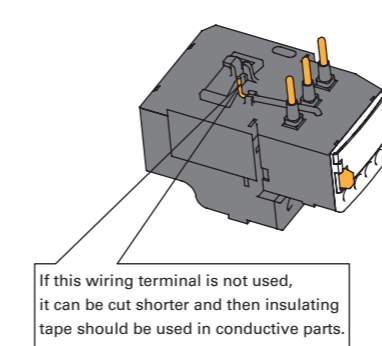
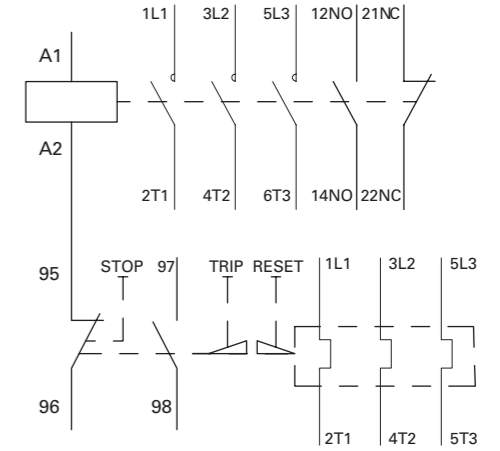

If this wiring terminal is not used, it can be cut shorter and then insulating tape should be used in conductive parts.

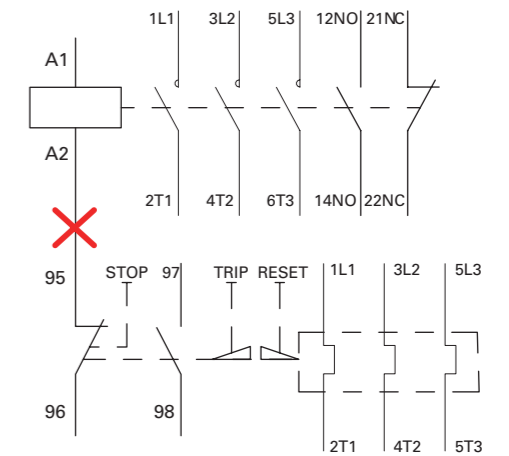

HDR3s Thermal Overload Relays

Standard: IEC60947-4



Assembly With Contactor

HDR3S 25 38 95
Independent Installation

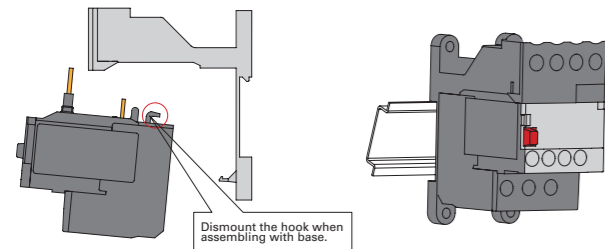

HDR3S 185
Assembly Installation

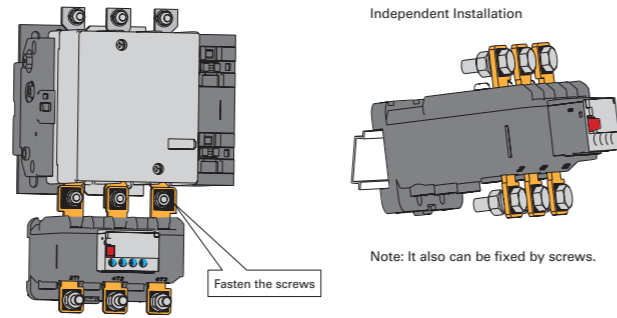

HDR3S 630
It only can be fixed by 75mm railway or screws

HDR3S 25 38 95 Installation Dimensions

HJRS1D25J

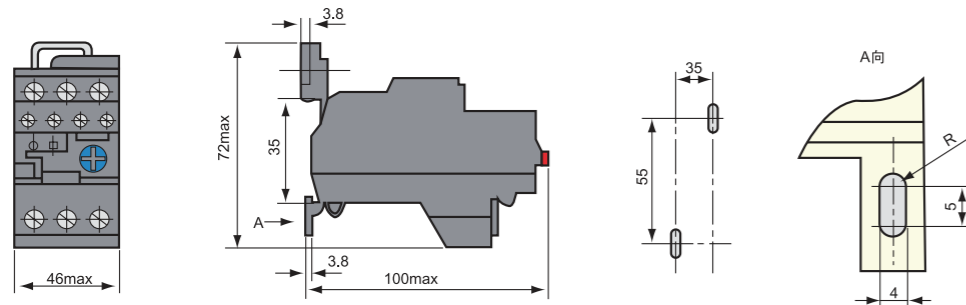

HJRS1D36J

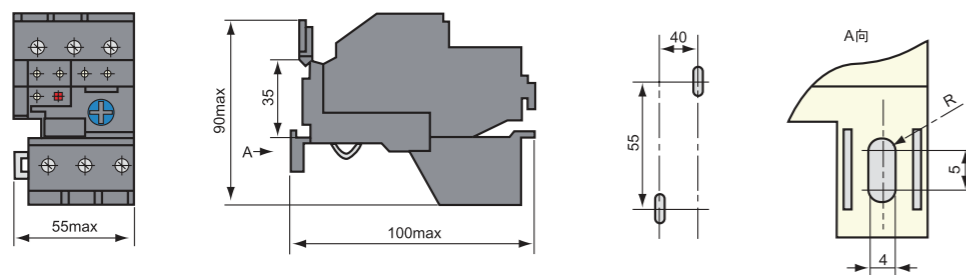

HJRS1D93J

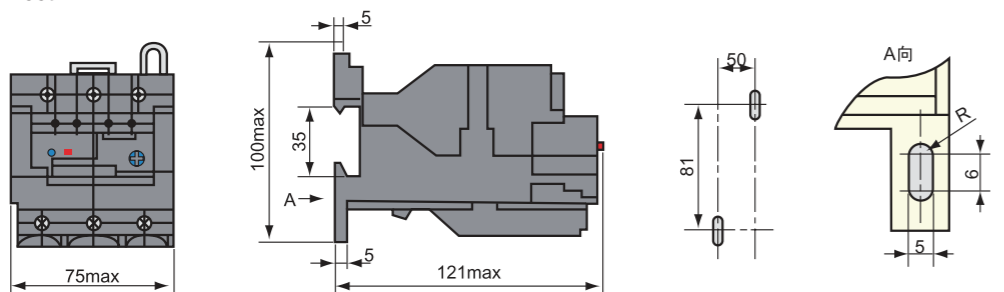

HJX2 4P AC Contactors

Standard: IEC60947-4



Range Presentation

HJX2 & HJX2F 4P AC contactor is Himel HJX series range of contactors designed for Motor Control AC3 applications up to 800A 690V.

HJX2 & HJX2F contactors are applicable to AC power systems 50Hz or 60Hz with rated operating voltage up to 690V.

HJX2 & HJX2F contactors can be combined with HDR3s thermal overload relays to provide overload protection.

Features

- ◆ Current specifications: 9-800A
- ◆ Pole: 4-pole
- ◆ Coil voltage: 24-440V
- ◆ Coil frequency: 50/60Hz

Online Content



HJX2

Selection Code

Range name	Current specification	Main contact	Coil voltage	Coil frequency
HJX2	09	4	M	7
HJX2	09: 09A 95: 95A	04: 4NO+0NC 08: 2NO+2NC	B: 24V C: 36V E: 48V F: 110V S: 127V M: 220/230V U: 240V Q: 380/400V L: 415V X: 440V	7: 50/60Hz

Overview of Accessories

HJX2 4P AC Contactor 09-95A

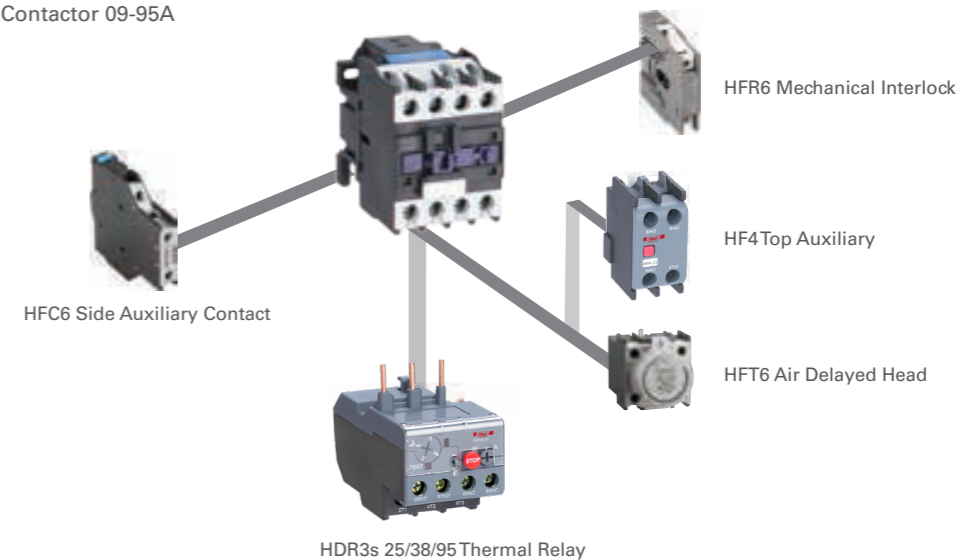

MOTOR MANAGEMENT

HJX2 4P AC Contactors

Standard: IEC60947-4



Technical Parameters										
AC Contactors		HJX2-09	HJX2-12	HJX2-25	HJX2-40	HJX2-50	HJX2-65	HJX2-80	HJX2-95	
Main circuit characteristics										
Maximum rated operating voltage (Ue)		690V								
Rated insulation voltage (Ui)		690V								
Rated impulse withstand voltage (Uimp)		8kV								
Conventional thermal current A		25	25	40	60	80	80	125	125	
Rated Operating Current	380/400V AC-3 A	9	12	25	40	50	65	80	95	
	660/690V AC-3 A	6.6	8.9	18	34	39	42	49	49	
	380/400V AC-4 A	3.3	5	8.5	18.5	24	28	37	44	
	660/690V AC-4 A	1.5	2	4.4	9	12	14	17.3	21.3	
Rated power of controlled 3-phase cage motor	380/400V AC-3 KW	4	5.5	11	18.5	22	30	37	45	
	660/690V AC-3 KW	5.5	7.5	15	30	33	37	45	45	
	380/400V AC-4 KW	1.2	2.2	4	7.5	11	15	18.5	22	
	660/690V AC-4 KW	1.1	1.5	4	7.5	11	11	15	18.5	
Electric durabilities	AC-3 ×10 ⁴ operations	100	100	100	80	80	80	60	60	
	AC-4 ×10 ⁴ operations	20	20	20	15	15	15	10	10	
Mechanical durabilities ×10 ⁴ operations		1000	1000	1000	800	800	800	600	600	
Operating frequency	AC-3 cycles/h	1200	1200	1200	600	600	600	600	600	
	AC-4 cycles/h	300	300	300	300	300	300	300	300	
Matched fuse		HRT16-25	HRT16-25	HRT16-50	HRT16-63	HRT16-80	HRT16-80	HRT16-125	HRT16-125	
Cable connection cross section mm ²		1.5	1.5	4	10	16	16	25	35	
Certificate		SEMKO								
Coil										
Coil voltage(Us)		V AC 24V, 36V, 110V, 220V, 380V								
Operating voltage		V 85%...110% Us								
Drop-out voltage		V 20%...75% Us								
Coil power	Actuation VA	70	70	110	200	200	200	200	200	
	Holding VA	9	9	11	24	24	24	24	24	
	Heat dissipation W	2.7	2.7	4	10	10	10	10	10	
Terminal wiring ability										
Flexible wire without terminal block	1pc(Section of connecting conduction mm ²)	1 - 4	1 - 4	1.5 - 6	2.5 - 25	2.5 - 25	2.5 - 25	4 - 50	4 - 50	
	2pcs(Section of connecting conduction mm ²)	1 - 4	1 - 4	1.5 - 6	2.5 - 16	2.5 - 16	2.5 - 16	4 - 25	4 - 25	
Flexible wire with terminal block	1pc(Section of connecting conduction mm ²)	1 - 4	1 - 4	1 - 6	2.5 - 25	2.5 - 25	2.5 - 25	4 - 50	4 - 50	
	2pcs(Section of connecting conduction mm ²)	1 - 2.5	1 - 2.5	1 - 4	2.5 - 10	2.5 - 10	2.5 - 10	4 - 16	4 - 16	
Fixed wire without terminal block	1pc(Section of connecting conduction mm ²)	1 - 4	1 - 4	1.5 - 6	2.5 - 25	2.5 - 25	2.5 - 25	4 - 50	4 - 50	
	2pcs(Section of connecting conduction mm ²)	1 - 4	1 - 4	1.5 - 6	2.5 - 16	2.5 - 16	2.5 - 16	4 - 25	4 - 25	
Auxiliary contact										
Rated thermal Current (Ith)		A 10								
Rated operating Voltage (Ue)	AC	V 400								
	DC	V 220								
Rated control capacity	AC-15	VA 360								
	DC-13	VA 33								

MOTOR MANAGEMENT

HJX2-F 4P AC Contactors

Standard: IEC60947-4



Range Presentation

HJX2 & HJX2F 4P AC contactor is Himel range of contactors designed for Motor Control AC3 applications up to 800A 690V.

HJX2 & HJX2F contactors are applicable to AC power systems 50Hz or 60Hz with rated operating voltage up to 690V.

HJX2 & HJX2F contactors can be combined with HDR3s thermal overload relays to provide overlaod protection.

Features

- ◆ Current Specifications: 115-800A
- ◆ Pole: 4 poles
- ◆ Coil Voltage: 110-440V
- ◆ Coil Frequency: 50/60Hz

Online Content



HJX2-F

Selection Code

Range name	Current specification	Main contact	Coil voltage	Coil frequency
HJX2F	115	4	M	7
HJX2F	115: 115A 150: 150A 800: 800A	4: 4NO+0NC	F: 110V S: 127V M: 220/230V U: 240V Q: 380/400V L: 415V X: 440V	7: 50/60Hz

Overview of Accessories

HJX2F 4P AC Contactor 115-800A

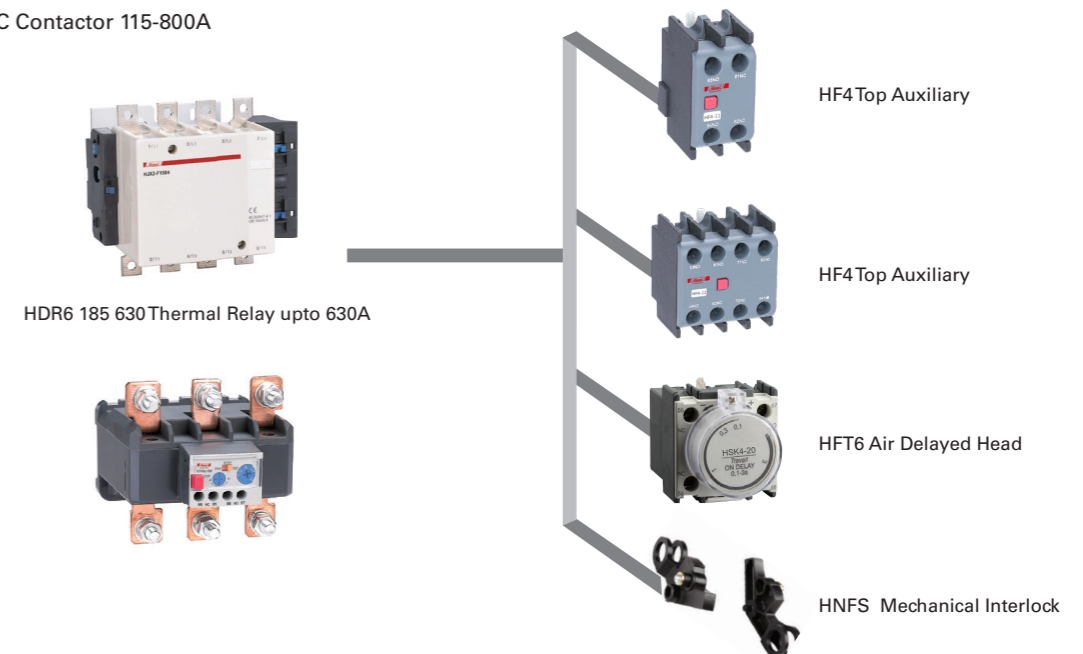

HJX2-F 4P AC Contactors

Standard: IEC60947-4



Technical Parameters											
AC Contactors		HJX2-F115	HJX2-F150	HJX2-F185	HJX2-F225	HJX2-F265	HJX2-F330	HJX2-F400	HJX2-F500	HJX2-F630	HJX2-F800
Main circuit characteristics											
Maximum Rated Operating voltage (Ue)		660/690V									
Rated Insulation Voltage (Ui)		690V									
Rated Impulse Withstand Voltage (Uimp)		8kV									
Conventional thermal current		200	250	275	315	350	400	500	630	800	800
Rated Operating Current	440V AC-3 A	115	150	185	225	265	330	400	500	630	800
	440V AC-4 A	52	60	79	85	105	117	138	147	188	195
	660V AC-3 A	86	107	118	135	170	235	305	355	460	493
	660V AC-4 A	49	57	69	82	98	107	135	145	170	175
	le max AC-1 Aθ ≤ 40 °C	200	250	275	315	350	400	500	630	800	800
Rated power of AC-3	220/240V	30	40	55	63	75	100	129	147	200	220
	380/400V	55	75	90	100	132	160	200	250	335	400
	415V	59	80	100	110	140	180	220	280	375	425
	440V	59	80	100	110	140	180	220	280	375	425
	500V	75	90	110	129	160	200	257	335	400	450
	660/690V	80	100	120	129	180	220	280	355	450	475
Electric durabilities	AC-3 ×10 ⁴ operations	60	60	50	50	50	50	30	30	20	15
	AC-4 ×10 ⁴ operations	15	15	15	15	15	15	8	8	5	4
Mechanical durabilities	×10 ⁴ operations	300	300	300	300	300	300	100	100	100	100
Operating frequency cycles/h	AC-1, AC-2, AC-3	600	600	600	600	600	600	300	300	300	300
	AC-4	150	150	150	150	150	150	150	150	150	150
Matched fuse	Model	HRT16-1	HRT16-1	HRT16-2	HRT16-2	HRT16-2	HRT16-3	HRT16-3	HRT16-3	HRT16-3	HRT16-4
	Rated current(A)	200	250	315	315	400	500	500	500	630	800
Cable connection cross section	mm ²	95	120	150	185	240	240	2*150	2*240	2*60*5	2*60*5
Certificate		CE									
Coil											
Coil Voltage(Us)	V	110V, 220V, 230V, 240V, 380V, 400V, 415V, 440V									
Operating voltage	Pull in voltage V	85%...110% Us									
Drop-out voltage	Drop-out voltage AC V	20%...75% Us									
	Drop-out voltage DC V	10%...75% Us									
Average Coil Power	Actuation AC VA	855	855	1180	1180	700	700	1150	1150	1730	1730
	Holding AC VA	8.1	8.1	10.9	10.9	10	10	18	20	25	25
	Actuation DC VA	665	665	902	902	803	803	1140	1220	1920	1920
	Holding DC VA	4.83	4.83	5.07	5.07	4.53	4.53	7.5	8	12.5	12.5
	Heat Dissipation W	7.2	7.2	9.8	9.8	10.4	10.4	14	18	20	20
Terminal Wiring Ability - Main Circuit											
Wiring Bar	Bar quantity	2	2	2	2	2	2	2	2	2	2
	Dimensions	20×3	25×3	25×3	32×3	32×4	30×5	30×5	40×5	60×5	60×5
Wire With Lug Plate	mm ²	95	120	150	185	240	240	2×150	2×240	---	---
Wire With Coupler	mm ²	95	120	150	185	240	---	---	---	---	---
Fastening Torque	N.m	10	18	18	35	35	35	35	35	58	58

HJX2 4P AC Contactors

Standard: IEC60947-4



Order Information

Motor P(kW) AC-380/400V	Rated current(A) AC-3 380/400V	Main contact		Reference
4	9	4	0	HJX20904*7
		2	2	HJX20908*7
5.5	12	4	0	HJX21204*7
		2	2	HJX21208*7
11	25	4	0	HJX22504*7
		2	2	HJX22508*7
18.5	40	4	0	HJX24004*7
		2	2	HJX24008*7
22	50	4	0	HJX25004*7
		2	2	HJX25008*7
30	65	4	0	HJX26504*7
		2	2	HJX26508*7
37	80	4	0	HJX28004*7
		2	2	HJX28008*7
45	95	4	0	HJX29504*7
		2	2	HJX29508*7



Motor P(kW) AC-380/400V	Rated current(A) AC-3 380/400V	Main contact		Reference
55	115	4	0	HJX2F1154*7
75	150	4	0	HJX2F1504*7
90	185	4	0	HJX2F1854*7
100	225	4	0	HJX2F2254*7
132	265	4	0	HJX2F2654*7
160	330	4	0	HJX2F3304*7
200	400	4	0	HJX2F4004*7
250	500	4	0	HJX2F5004*7
335	630	4	0	HJX2F6304*7
400	800	4	0	HJX2F8004*7



HJX2 4P AC Contactors

Standard: IEC60947-4



HF4 Top Auxiliary Contact

Pole	Contact		Wiring diagram	Reference
	NO	NC		
2P	1	1		HF411
	0	2		HF402
	2	0		HF420
4P	0	4		HF404
	1	3		HF413
	2	2		HF422
	3	1		HF431
	4	0		HF440



HFC6 Side Auxiliary Contact

Pole	Contact		Wiring diagram	Reference
	NO	NC		
2P	0	2		HFC602
	1	1		HFC611
	2	0		HFC620



HJX2 4P AC Contactors

Standard: IEC60947-4



HFT6 Air Delayed Head

Delay Type	Wiring diagram	Delay Range	Reference
Making time-delay		0.1-3S	HFT6420
		0.1-30S	HFT6422
		10-180S	HFT6424
Breaking time-delay		0.1-3S	HFT6430
		0.1-30S	HFT6432
		10-180S	HFT6434



Contactor

	9	12	25	40	50	65	80	95
Mechanical interlocking module	9-25A:HFR632HX 40-95A:HFR695HX							
Thermal overload relays	HDR3s-25 0.1-0.16A ... 17-25A		HDR3s-38 23-32A 30-40A			HDR3s-93 23-32A ... 80-93A		



Horizontal Installation

Interlock Method	Contact Type	Reference
Mechanical interlock without electrical terminals	HJX2-F 4P-115~150	HNFS1504
	HJX2-F 4P-185~225	HNFS2254
	HJX2-F 4P-265~330	HNFS3304
	HJX2-F 4P-400~500	HNFS5004
	HJX2-F 4P-630~800	HNFS8004



HJX2 4P AC Contactors

Standard: IEC60947-4



Technical Data

Terminal Wiring Ability - Main Circuit		
Flexible Wire Without Terminal Block	1pc(Section of Connecting Conduction mm ²)	1~4
	2pcs(Section of Connecting Conduction mm ²)	1~4
Flexible Wire With Terminal Block	1pc(Section of Connecting Conduction mm ²)	1~4
	2pcs(Section of Connecting Conduction mm ²)	1~2.5
Fixed Wire Without Terminal Block	1pc(Section of Connecting Conduction mm ²)	1~4
	2pcs(Section of Connecting Conduction mm ²)	1~4
Fastening Torque	N.m	1.2
Auxiliary Contact		
Rated Thermal Current (I _{th})	A	10
Rated Operating Voltage (U _e)	AC V	400
	DC V	220
Rated Control Capacity	AC-15 VA	360
	DC-13 VA	33

Working Conditions

- Ambient temperature for operating: -5°C +40°C , and the daily average temperature ≤ 35°C .
- Ambient temperature for storage and transportation: -25...+55 °C and can reach 70°C in a short time.
- Altitude: ≤ 2000 m, and the altitude could be higher under lower operating voltage and operating current.
- The atmospheric relative humidity does not exceed 50% when the highest ambient temperature is +40°C. It is allowed to have a higher humidity under lower temperature, e.g. up to 90% at +20°C. For occasional dew due to the temperature change, preventive measures shall be taken.
- Pollution Level: 3
- Protection class: IP00 (IP20 if it's with terminal protection cover)

Installation Conditions

- Installation Type: III
- Installation position: should be installed in the absence of a significant shock and vibration place. The installation site shall be vertical , and inclination at all directions shall not exceed ±5°. When the coil control voltage is not lower than 85%U_s, the inclination should be no more than ±30°.

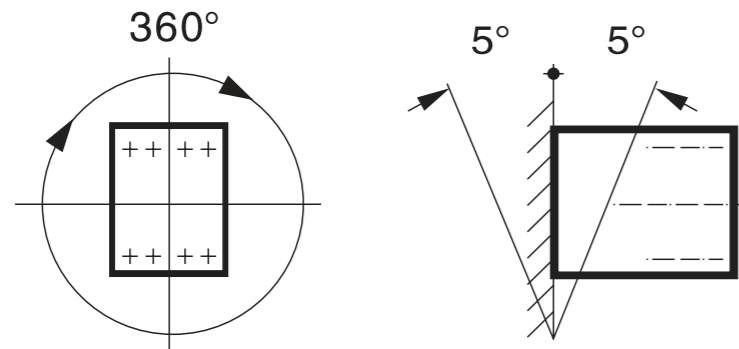

HJX2 4P AC Contactors

Standard: IEC60947-4



Installation Dimensions

Overall Dimensions

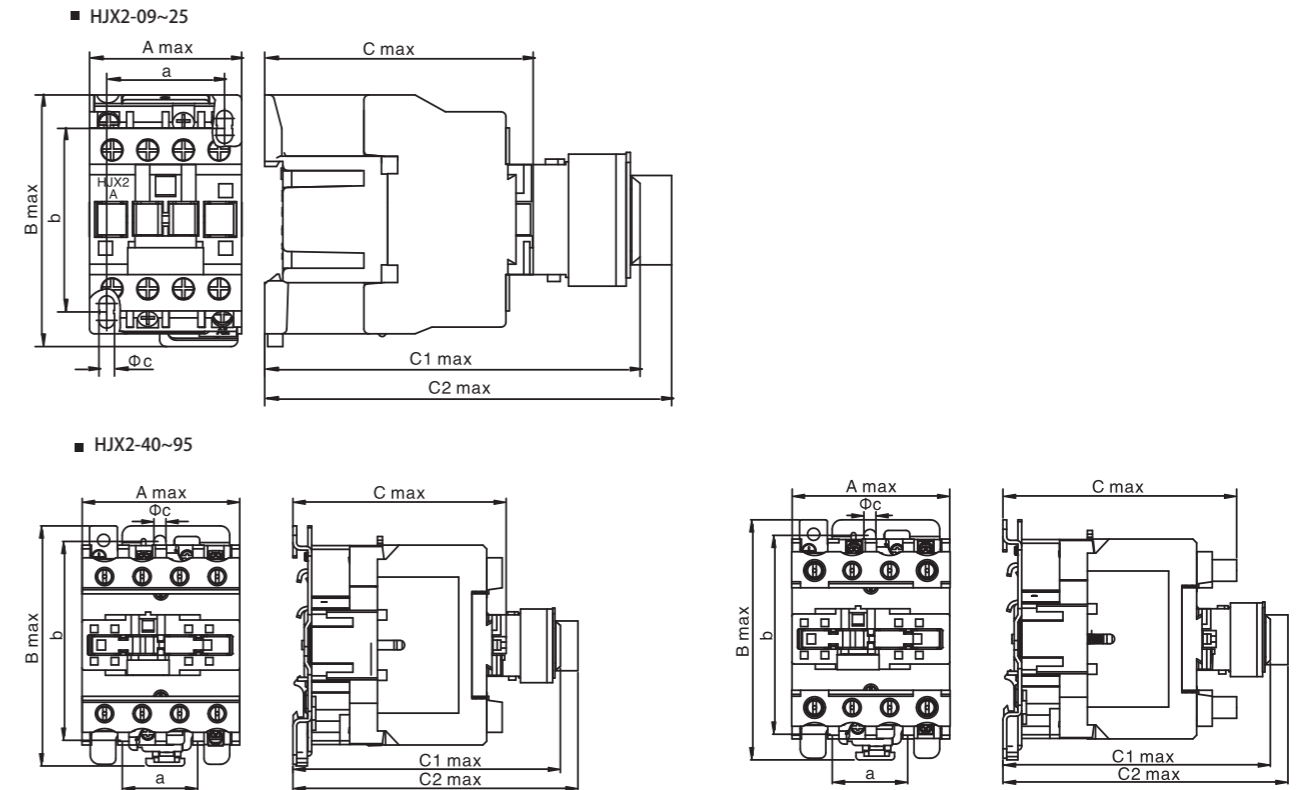

Overall Dimensions & Mounting Figures

Unit:mm

Model	A max	B max	C max	C1 max	C2 max	a	b	c
HJX2-0904,0908,1204,1208	47	76	82	115	134	35	50/60	4.5
HJX2-2504,2508	58	86	96	130	149	40	50/60	4.5
HJX2-4004,5004,6504	85	128	116	149	168	40	100/110	6.5
HJX2-4008,5008,6508	85	128	126	149	168	40	100/110	6.5
HJX2-8004,9504	96	128	127	160	179	40	100/110	6.5
HJX2-8008,9508	96	128	136	160	179	40	100/110	6.5

Remark: C1max—Cotactor+HF4(or HFD6) C2max—Cotactor+HSK4(or HFT6)

Wiring Diagram

■ HJX2-0904~9504

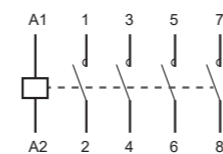

■ HJX2-0908~2508

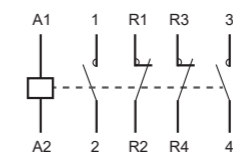

■ HJX2-4008~9508

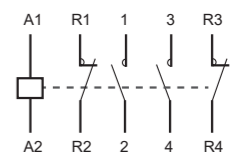

HJX2 4P AC Contactors

Standard: IEC60947-4



Overall Dimensions

HJX2-F115~330

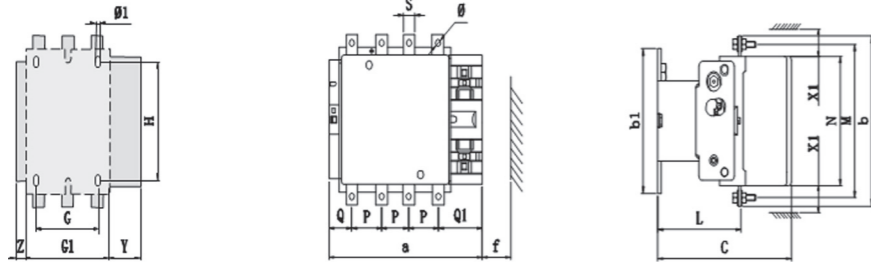

HJX2-F400~500

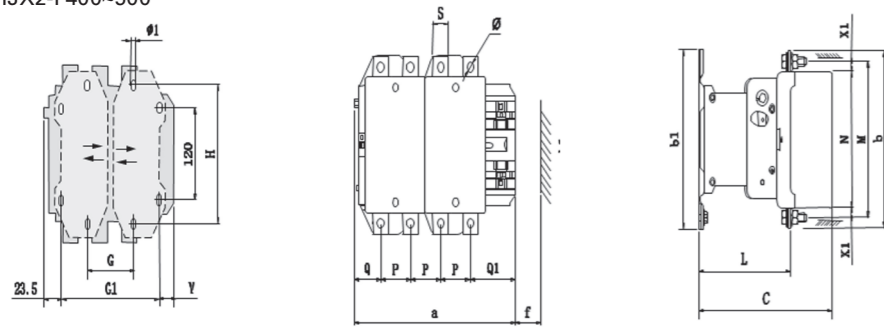

HJX2-F630~800

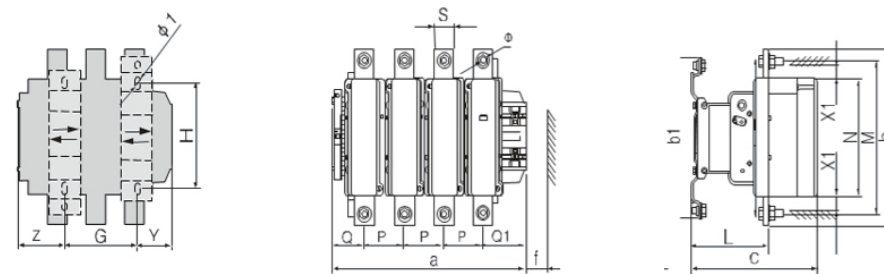

HJX2-F115~800 Overall Dimensions and Mounting Figures

HJX2-F	a	P	Q	Q1	S	φ	f	b	b1	M	N	C	L	G	H	φ1	G1	Z	Y	X1	
																				500V	≥500V
1154	220.5	37	29.5	60	20	M6	131	162	137	147	124	171	107	80	120-106	6.5	143	13.5	44	10	15
1504	200.5	40	25	55.5	20	M8	131	170	137	150	124	171	113.5	80	120-106	6.5	143	13.5	44	10	15
1854	208.5	40	29	59.5	20	M8	130	174	137	154	127	181	113.5	80	120-106	6.5	151	13.5	44	10	15
2254	208.5	48	17	47.5	25	M10	130	197	137	172	127	181	113.5	80	120-106	6.5	151	20.5	44	10	15
2654	244.5	48	34	66.5	25	M10	147	203	145	178	147	213	141	96	120-106	6.5	186	20.5	38	10	15
3304	261	48	43	74	25	M10	147	206	145	181	158	219	145	96	120-106	6.5	202.5	20.5	38	10	15
4004	261	48	43	74	25	M10	151	206	209	181	158	219	145	80(66-102)	180	8.5	170(156-192)	23.5	67.5	15	20
5004	288	55	46	77	30	M10	169	238	209	208	172	232	146	140(66-175)	180	8.5	230(156-265)	23.5	34.5	15	20
6304	389	80	60	89	40	M12	201	304	280	264	202	255	155	240(150-275)	180	10.5	---	60.5	68.5	20	30
8004	389	80	60	89	40	M12	201	304	280	264	202	255	155	240(150-275)	180	10.5	---	60.5	68.5	20	30

Wiring Diagram

HJX2-F1154-8004

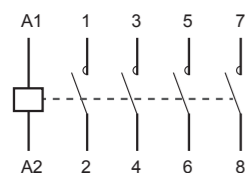

HJSZ3 Electronic Timer Relays

Standard: IEC60947-4



Range Presentation

HJSZ3 is Himel range of Electronic Timer relay designed for industrial control applications.

HJSZ3 is applicable to AC 50Hz circuits with controlling voltage up to 400V.

Features

- ◆ Multi-position type Time delay range
- ◆ Power-on/off delay type available
- ◆ Wild rated voltage input range from 85%~110%

Online Content



HJSZ3

Selection Code

Range name	Time delay	Operation voltage	Range name	Time delay	Operation voltage
HJSZ3A	A	120	HJSZ3F	2S	120
Time delay after power-on	A: 0.05-0.5s/5s/30s/3M B: 0.1-1s/10s/60s/6M C: 0.5-5s/50s/5M/30M D: 1-10s/100s/10M/60M E: 6s-60s/10M/60M/6h F: 0.2M-2M/20M/2h/12h G: 0.4M-4M/40M/4h/24h	120 240 400	Time delay after power-off	1S: 0.1-1s 2S: 0.2-2s 3S: 0.3s-3s 5S: 0.5s-5s 6S: 0.6s-6s 10S: 1s-10s 20S: 2s-20s 30S: 3s-30s 60S: 6s-60s 100S: 10s-100s 180S: 18s-180s 5M: 0.5min-5min 6M: 0.6min-6min 10M: 1min-10min 20M: 2min-20min 30M: 3min-30min	120 240 400

Technical Parameters	
Electronic Timer Relays	HJSZ3
Condition	AC-15 DC-13
Repetitive error	≤5%
Rated thermal current	5A
Mechanical life	≥1 × 10 ⁶ times
Electric life	≥1 × 10 ⁵ times
Power loss	≤3W
Working mode	A: Delay after power-on F: Delay after power-off
Reset mode	A: Power-off reset F: External device reset
Contactor endurance	A: 5A (Resistive) F: 1A(Resistive)
Delay time	HJSZ3A: 0.05s-0.5s/5s/30s/3M, 0.1s-1s/10s/60s/6M 0.5s-5s/50s/5M/30M, 1s-10s/100s/10M/60M 6s-60s/10M/60M/6h, 0.2M-2M/20M/2h/12h 0.4M-4M/40M/4h/24h HJSZ3F: 0.1s-1s, 0.2s-2s, 0.3s-3s, 0.5s-5s, 0.6s-6s, 1s-10s, 2s-20s, 3s-30s, 6s-60s, 10s-100s, 10s-120s, 10s-180s, 0.4M-4M, 0.5M-5M, 0.6M-6M, 1M-10M, 2M-20M, 3M-30M
Temperature	-5°C ~ +40°C
Installation mode	Din rail mounted, Panel mounted

HJSZ3 Electronic Timer Relays

Standard: IEC60947-4

Order Information

Relay mode	Rated operating voltage	Relay time	Reference
Relay after power-on	120V	A: 0.05-0.5s/5s/30s/3M	HJSZ3AA120
		B: 0.1-1s/10s/60s/6M	HJSZ3AB120
		C: 0.5-5s/50s/5M/30M	HJSZ3AC120
		D: 1-10s/100s/10M/60M	HJSZ3AD120
		E: 6s-60s/10M/60M/6h	HJSZ3AE120
		F: 0.2M-2M/20M/2h/12h	HJSZ3AF120
		G: 0.4M-4M/40M/4h/24h	HJSZ3AG120
	240V	A: 0.05-0.5s/5s/30s/3M	HJSZ3AA240
		B: 0.1-1s/10s/60s/6M	HJSZ3AB240
		C: 0.5-5s/50s/5M/30M	HJSZ3AC240
		D: 1-10s/100s/10M/60M	HJSZ3AD240
		E: 6s-60s/10M/60M/6h	HJSZ3AE240
		F: 0.2M-2M/20M/2h/12h	HJSZ3AF240
		G: 0.4M-4M/40M/4h/24h	HJSZ3AG240
	400V	A: 0.05-0.5s/5s/30s/3M	HJSZ3AA400
		B: 0.1-1s/10s/60s/6M	HJSZ3AB400
		C: 0.5-5s/50s/5M/30M	HJSZ3AC400
		D: 1-10s/100s/10M/60M	HJSZ3AD400
		E: 6s-60s/10M/60M/6h	HJSZ3AE400
		F: 0.2M-2M/20M/2h/12h	HJSZ3AF400
		G: 0.4M-4M/40M/4h/24h	HJSZ3AG400



Relay mode	Rated operating voltage	Relay time	Reference
Relay after power-off	120V	1S: 0.1-1s	HJSZ3F1S120
		2S: 0.2-2s	HJSZ3F2S120
		3S: 0.3s-3s	HJSZ3F3S120
		5S: 0.5s-5s	HJSZ3F5S120
		6S: 0.6s-6s	HJSZ3F6S120
		10S: 1s-10s	HJSZ3F10S120
		20S: 2s-20s	HJSZ3F20S120
		30S: 3s-30s	HJSZ3F30S120
		60S: 6s-60s	HJSZ3F60S120
		100S: 10s-100s	HJSZ3F100S120
		180S: 18s-180s	HJSZ3F180S120
		4M: 0.4min-4min	HJSZ3F4M120
		5M: 0.5min-5min	HJSZ3F5M120
		6M: 0.6min-6min	HJSZ3F6M120
10M: 1min-10min	HJSZ3F10M120		
20M: 2min-20min	HJSZ3F20M120		

HJSZ3 Electronic Timer Relays

Standard: IEC60947-4

Order Information

Relay mode	Rated operating voltage	Relay time	Reference	
Relay after power-off	120V	30M: 3min-30min	HJSZ3F30M120	
		1S: 0.1-1s	HJSZ3F1S240	
		2S: 0.2-2s	HJSZ3F2S240	
		3S: 0.3s-3s	HJSZ3F3S240	
		5S: 0.5s-5s	HJSZ3F5S240	
		6S: 0.6s-6s	HJSZ3F6S240	
		10S: 1s-10s	HJSZ3F10S240	
		20S: 2s-20s	HJSZ3F20S240	
		30S: 3s-30s	HJSZ3F30S240	
		60S: 6s-60s	HJSZ3F60S240	
		100S: 10s-100s	HJSZ3F100S240	
		180S: 18s-180s	HJSZ3F180S240	
	240V	4M: 0.4min-4min	HJSZ3F4M240	
		5M: 0.5min-5min	HJSZ3F5M240	
		6M: 0.6min-6min	HJSZ3F6M240	
		10M: 1min-10min	HJSZ3F10M240	
		20M: 2min-20min	HJSZ3F20M240	
		30M: 3min-30min	HJSZ3F30M240	
		1S: 0.1-1s	HJSZ3F1S400	
		2S: 0.2-2s	HJSZ3F2S400	
		3S: 0.3s-3s	HJSZ3F3S400	
		5S: 0.5s-5s	HJSZ3F5S400	
		6S: 0.6s-6s	HJSZ3F6S400	
		10S: 1s-10s	HJSZ3F10S400	
	20S: 2s-20s	HJSZ3F20S400		
	400V	30S: 3s-30s	HJSZ3F30S400	
		60S: 6s-60s	HJSZ3F60S400	
		100S: 10s-100s	HJSZ3F100S400	
		180S: 18s-180s	HJSZ3F180S400	
		5M: 0.5min-5min	HJSZ3F5M400	
		6M: 0.6min-6min	HJSZ3F6M400	
		10M: 1min-10min	HJSZ3F10M400	
		20M: 2min-20min	HJSZ3F20M400	
		30M: 3min-30min	HJSZ3F30M400	
		Base for HJSZ3		HTP28XEDZ

Overall Dimensions

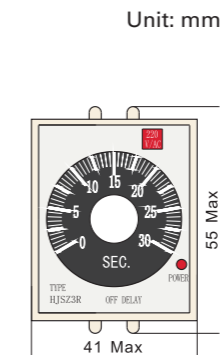
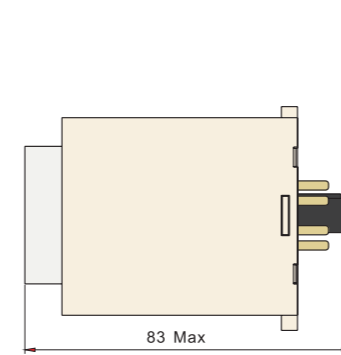

Base

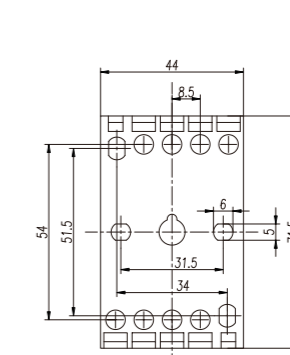

MOTOR MANAGEMENT

HXJ9 Phase Failure And Sequence Protection Relay

Standard: IEC 60947-5-1



Function

HXJ9 phase failure and sequence protection relay provides:

- ◆ Rated frequency is 50Hz, and rated control supply AC voltage is 400V
- ◆ Phase failure and phase sequence protections

Order Information

Function	Voltage	Reference
Phase Failure and sequence Protection	380V	HXJ9
	400V	HXJ9400

Technical Data

Standard	IEC 60947-5-1
Overvoltage protection	Adjustable, HXJ9: 380~460V, HXJ9400: 400~480V, Reaction time: 1.5s-4s (adjustable)
Undervoltage protection	Adjustable, HXJ9: 300~380V, HXJ9400: 320~400V. Reaction time: 2s-9s (adjustable)
Phase failure & phase wrong protect time	Reaction time ≤2s
Contact mode	1 NO, 1NC
Contact endurance	5A Resistive
Power voltage	AC 400V
Mechanical lifetime	1×10 ⁶ times
Electrical lifetime	≥1×10 ⁵ times
Power loss	≤1W
Contact capacity	AC400V×3

Overall Dimensions

Unit: mm

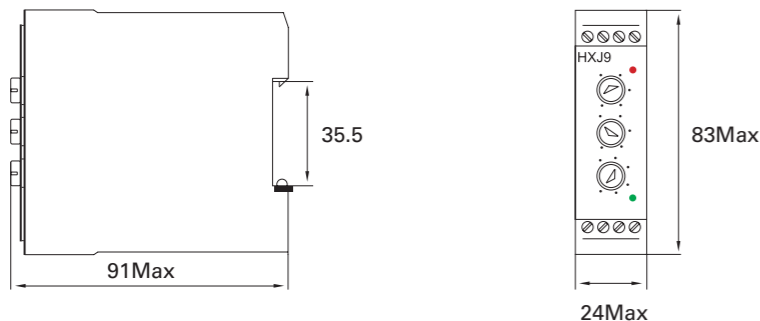

MOTOR MANAGEMENT

HDC17K Miniature AC Contactors

Standard: IEC60947-4



Range Presentation

HDC17K is Himel Miniature AC Contactor for Remote make & break of circuits

Frequent start and stop of small power motors

Features

- ◆ Current: 6-12A
- ◆ Pole: 3/4-pole
- ◆ Coil voltage: 24-400V
- ◆ Coil frequency: 50/60Hz

Online Content



HDC17K

Selection Code

Range name	Current specification	Main contact	Auxiliary contact	Coil voltage	Coil frequency
HDC17K	06	30	10	M	5
HDC17K	06: 06A	30: 3NO	10: 1NO 01: 1NO	B: 24V C: 36V F: 110V S: 127V M: 220/230V Q: 380/400V	7: 50/60Hz
	09: 09A	40: 4NO	00: 0NO+0NC		
	12: 12A	22: 2NO+2NC	00: 0NO+0NC		

Order Information

Motor P(kW) 380V	Rated current(A)	Main contact		Auxiliary contact		Reference
		NO	NC	NO	NC	
2.2	6	3	0	1	0	HDC17K63010*
		3	0	0	1	HDC17K63001*
		4	0	0	0	HDC17K64000*
4	9	2	2	0	0	HDC17K62200*
		3	0	1	0	HDC17K93010*
		3	0	0	1	HDC17K93001*
4	12	4	0	0	0	HDC17K94000*
		2	2	0	0	HDC17K92200*
		3	0	1	0	HDC17K123010*
		3	0	0	1	HDC17K123001*
		4	0	0	0	HDC17K124000*

HDC17K Miniature AC Contactors

Standard: IEC60947-4



Technical Parameters					
Miniature AC Contactors			HDC17-K06	HDC17-K09	HDC17-K12
Main circuit characteristics					
Rated operating current	380V/400V, AC-3	A	6	9	12
	380V/400V, AC-4	A	2.6	3.5	5
	660V/690V, AC-3	A	3.5	5	6
	660V/690V, AC-4	A	1.2	1.5	2
Rated operating voltage		V	220/230, 380/400, 660/690		
Rated insulation voltage		V	690		
Rated conventional thermal current		A	16	20	20
Pole			3, 4		
Power of controlled 3-phase cage motor	220V/230V, AC-3	kW	1.5	2.2	3
	380V/400V, AC-3	kW	2.2	4	5.5
	660V/690V, AC-3	kW	3	4	4
Electric endurance	AC-3	×10 ⁴ operations	100		
Operating rate		cycles/h	1200		
Electric endurance	AC-4	×10 ⁴ operations	20		
Operating rate		cycles/h	600		
Mechanical endurance		×10 ⁴ cycles	1000		
Matched Fuse			HRT16-16	HRT16-20	
Cable connection	Inflexible cable	number of piece	2		
	Cross Section of Cable	mm ²	4		
Certificate			CB, CE		
Coil					
Coil voltage(Us)		V	AC 24V,36V,110V,127V,220/230V,380/400V		
Operating voltage		V	85% ~ 110% Us		
Drop-out voltage		V	20% ~ 75% Us		
Inrush		VA	30		
Auxiliary contact					
Rated conventional thermal current		V	690		
Rated insulation voltage		A	10		
Rated operating current		A	0.95		
Control capacity	380V, AC-15	A	0.15		
	220V, DC-13	VA	360		
	AC-15	W	33		
	DC-13				

HDC17K Miniature AC Contactors

Standard: IEC60947-4



Order Information

Motor P(kW) 380V	Rated current(A)	Main contact		Auxiliary contact		Reference
		NO	NC	NO	NC	
2.2	6	3	0	1	0	HDC17K63010*.
		3	0	0	1	HDC17K63001*.
		4	0	0	0	HDC17K64000*.
		2	2	0	0	HDC17K62200*.
4	9	3	0	1	0	HDC17K93010*.
		3	0	0	1	HDC17K93001*.
		4	0	0	0	HDC17K94000*.
4	12	2	2	0	0	HDC17K92200*.
		3	0	1	0	HDC17K123010*.
		3	0	0	1	HDC17K123001*.
		4	0	0	0	HDC17K124000*.



HF4K Top Auxilliary Contact

Pole	Contact		Wiring Diagram	Reference
	NO	NC		
2P	1	1		HF4K11
	0	2		HF4K02
	2	0		HF4K20
	0	4		HF4K04
4P	1	3		HF4K13
	2	2		HF4K22
	3	1		HF4K31
	4	0		HF4K40

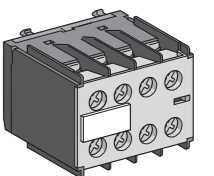
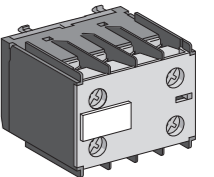

MOTOR MANAGEMENT

HDC17K Miniature AC Contactors

Standard: IEC60947-4



Working Conditions

- Ambient temperature : -5°C~+40°C, and the daily average temperature ≤ 35°C
- Altitude : ≤ 2000 m
- Humidity : Maximum temperature is +40°C, and air relative humidity is no more than 50%; at a lower temperature a higher relative humidity is allowed. For example, when humidity is up to 90% at 20°C due to the temperature change resulting from Gel happening occasionally, special measures should be taken.
- Pollution Level : 3
- Installation Type : III
- Installation position : should be installed in the absence of a significant shock and vibration place

Installation Location

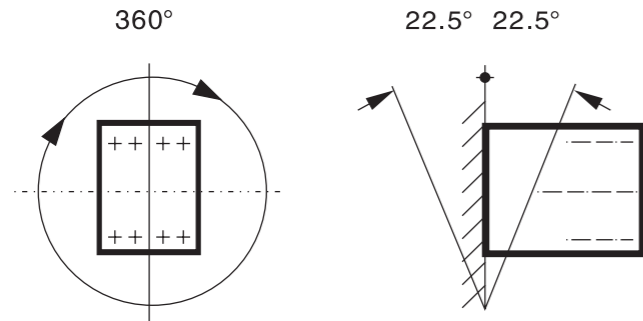

Overall Dimensions

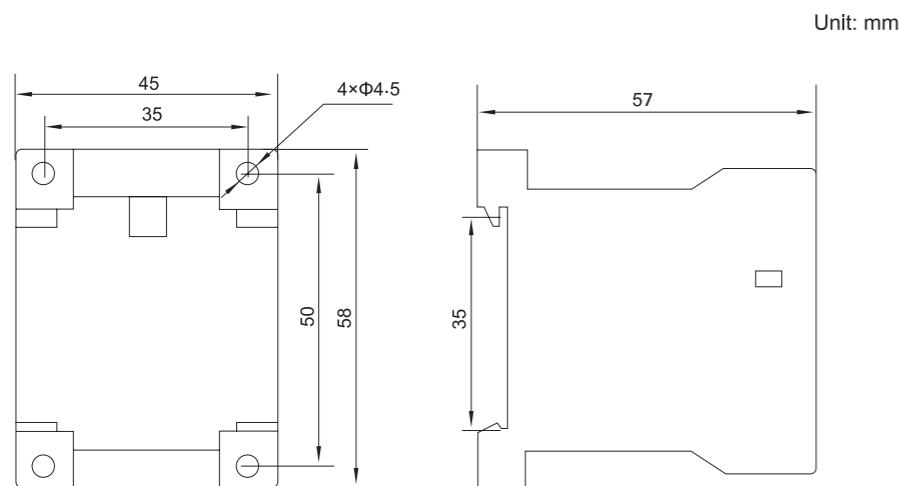

MOTOR MANAGEMENT

HDZ3 Contactor Relays

Standard: IEC60947-4

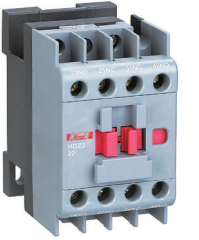

Online Content



HDZ3

Range Presentation

HDZ3 is Himel 3 series range of contactor relays design for industrial control applications.

HDZ3 contactor relays are suitable for AC and DC 50/60Hz control circuits.

Features

- ◆ For both DC and AC 50/60Hz control circuits
- ◆ 3 poles, similar design as HDC3 contactor
- ◆ 4 contacts with different NO+NC combinations
- ◆ Wide range of coil voltages 24V-440V

Selection Code

Range name	Main contact	Coil voltage	Coil frequency
HDZ3	22	M	5
HDZ3	22: 2NO+2NC 31: 3NO+1NC 40: 4NO+0NC 13: 1NO+3NC 04: 0NO+4NC	B: 24V C: 36V E: 48V F: 110V S: 127V M: 220/230V U: 240V Q: 380/400V L: 415V X: 440V	5: 50Hz 7: 50/60Hz

Overview of Accessories

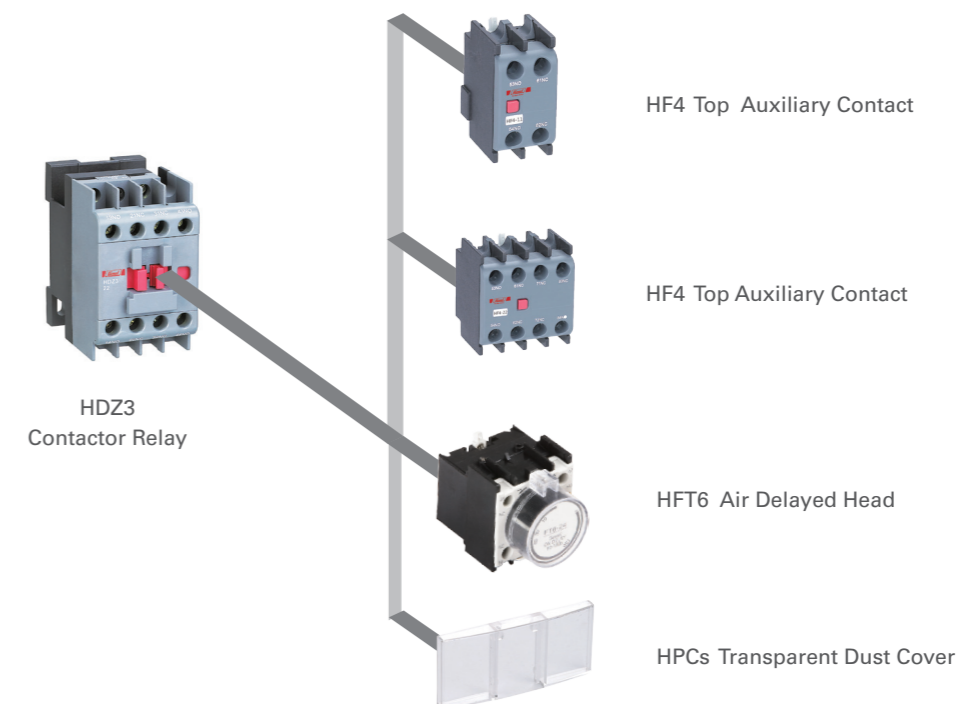

HDZ3 Contactor Relays

Standard: IEC60947-4



Technical Parameters

Contact Relays		HDZ3
Rated insulation voltage (Ui)	V	690
Conventional thermal current (Ith)	A	10
Rated operating current (Ie)	A	AC-15 380V: 0.95
		DC-13 220V: 0.15
Contact combination		2NO+2NC, 3NO+1NC, 4NO+0NC, 1NO+3NC, 0NO+4NC
Electrical endurance	10,000 times	110
Mechanical endurance	10,000 times	1100
Operating frequency	times/Hour	1200
Rated control circuit voltage(Us)	50Hz	24, 36, 48, 110, 127, 220/230, 240, 380/400, 415, 440
	50/60Hz	24, 36, 48, 110, 127, 220/230, 240, 380/400, 415, 440
Operating voltage range	V	AC 85%...110% Us
Drop-out voltage range	V	AC 20%...75% Us
Certificate		CE, CB, SEMKO

Order information

	Contact		Reference
	NO	NC	
	2	2	HDZ322*
	3	1	HDZ331*
	4	0	HDZ340*
	1	3	HDZ313*
	0	4	HDZ304*

Coil voltage code

Coil voltage(V)	24	36	48	110	127	220/230	240	380/400	415	440
*	B	C	E	F	S	M	U	Q	L	X

Note: * means coil voltage code

HDZ3 Contactor Relays

Standard: IEC60947-4



Wiring Diagram

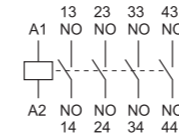

HDZ3-40

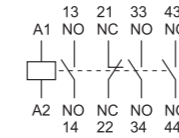

HDZ3-31

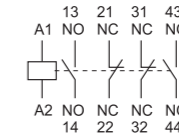

HDZ3-22

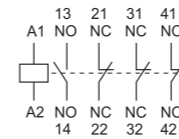

HDZ3-13

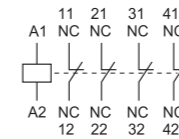

HDZ3-04

Overall and installation dimensions

HDZ3

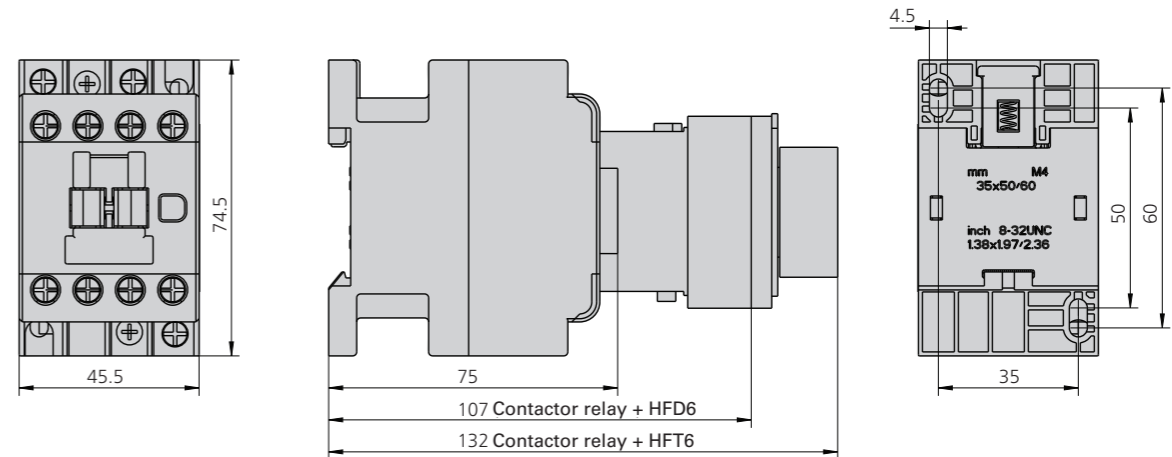

MOTOR MANAGEMENT

HDP6 Motor Circuit Breakers

Standard: IEC60947-4



Range Presentation

HDP6 Motor Control & Protection range is meant to help optimize and secure your installation from HVAC to small Genset applications. It also helps your packaging or pumping businesses to run on a reliable product.

The range covers application up to 32A including wide range of voltage from 230V up to 690V

Features

- ◆ Frame Current: 32A, 80A
- ◆ Setting Current: 0.1-32A, 25-80A

Online Content



HDP6

Selection Code

Range name	Frame size	Setting currents
HDP6	32	P16
HDP6	32: 32A	P16: 0.1-0.16A 32: 24-32A
HDP17Z	80: 80A	40: 25-40A 63: 40-63A 80: 56-80A

Overview of Accessories

HDP6-32

HDP17Z-80

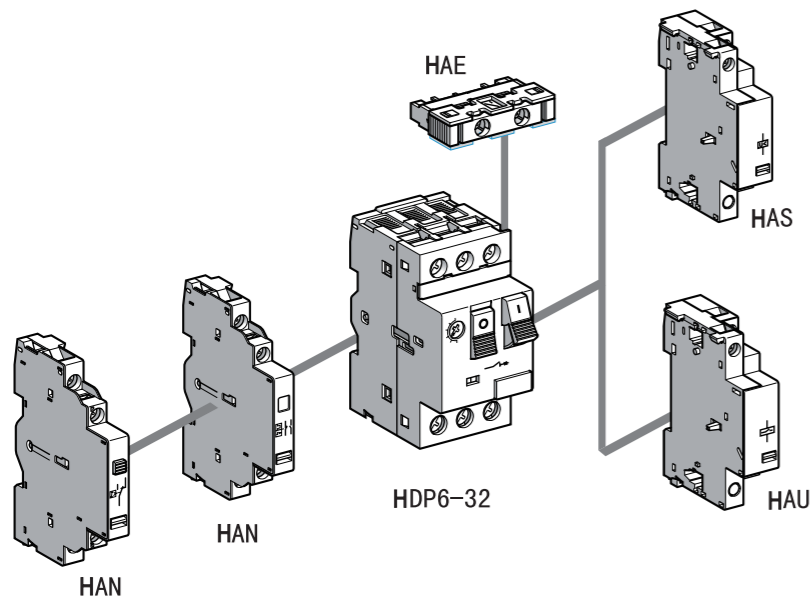

MOTOR MANAGEMENT

HDP6 Motor Circuit Breakers

Standard: IEC60947-4



Technical Parameter									
Rated Isolation Voltage Ui V		690							
Rated Operational Voltage Ue V		230/240, 400/415, 440, 500, 690							
Rated Impulse Withstand Voltage Uimp V		6000							
Rated Frequency Hz		50/60							
Applicable Category		AC - 3A							
Operation Mode		Button Type							
Trip Class		10A							
Electrical Durability Times		100000							
Mechanical Durability Times		100000							
Flash-Over Distance mm		≥ 40							
Accessories		Under-Voltage Release, Shunt Release, Instantaneous Auxiliary Contact (Side and Face-up Installation)							
Rated Current In A		0.16	0.25	0.4	0.63	1	1.6	2.5	4
Setting Current A		0.10-0.16	0.16-0.25	0.25-0.40	0.40-0.63	0.63-1.00	1.00-1.60	1.60-2.50	2.50-4.00
Rated Operating Power KW Class AC-3 50/60 HZ	400V	-	-	-	-	-	0.37	0.75	1.5
	690V	-	-	-	0.37	0.55	1.1	1.5	3
Breaking Capacity KA	400V Icu	100	100	100	100	100	100	100	100
	690V Ics	100	100	100	100	100	100	100	100
	400V Icu	100	100	100	100	100	100	3	3
	690V Ics	100	100	100	100	100	100	2.25	2.25

Technical Parameter											
Rated Isolation Voltage Ui V		690									
Rated Operational Voltage Ue V		230/240, 400/415, 440, 500, 690									
Rated Impulse Withstand Voltage Uimp V		6000									
Rated Frequency Hz		50/60									
Applicable Category		AC - 3A									
Operation Mode		Button Type									
Trip Class		10A									
Electrical Durability Times		100000									
Mechanical Durability Times		100000									
Flash-Over Distance mm		≥ 40									
Accessories		Under-Voltage Release, Shunt Release, Instantaneous Auxiliary Contact (Side and Face-up Installation)									
Rated Current In A		6.3	10	14	18	23	25	32	40	63	80
Setting Current A		4.00-6.30	6.00-10.0	9.00-14.0	13.0-18.0	17.0-23.0	20.0-25.0	24.0-32.0	25.0-40.0	40.0-63.0	56.0-80.0
Rated Operating Power KW Class AC-3 50/60 HZ	400V	2.2	4	5.5	7.5	11	11	15	16	20	25
	690V	4	7.5	9	11	15	18.5	23	18.5	30	40
Breaking Capacity KA	400V Icu	100	100	15	15	15	15	10	30	30	35
	690V Ics	100	100	7.5	7.5	6	6	5	15	15	17.5
	400V Icu	3	3	3	3	3	3	3	5	6	8
	690V Ics	2.25	2.25	2.25	2.25	2.25	2.25	2.25	2.25	2.25	3

Note: Ics means the breaking capacity of rated short circuit operation; Icu means the breaking capacity of rated short circuit limited short circuit.

HDP6 Motor Circuit Breakers

Standard: IEC60947-4



Introduction for Functions

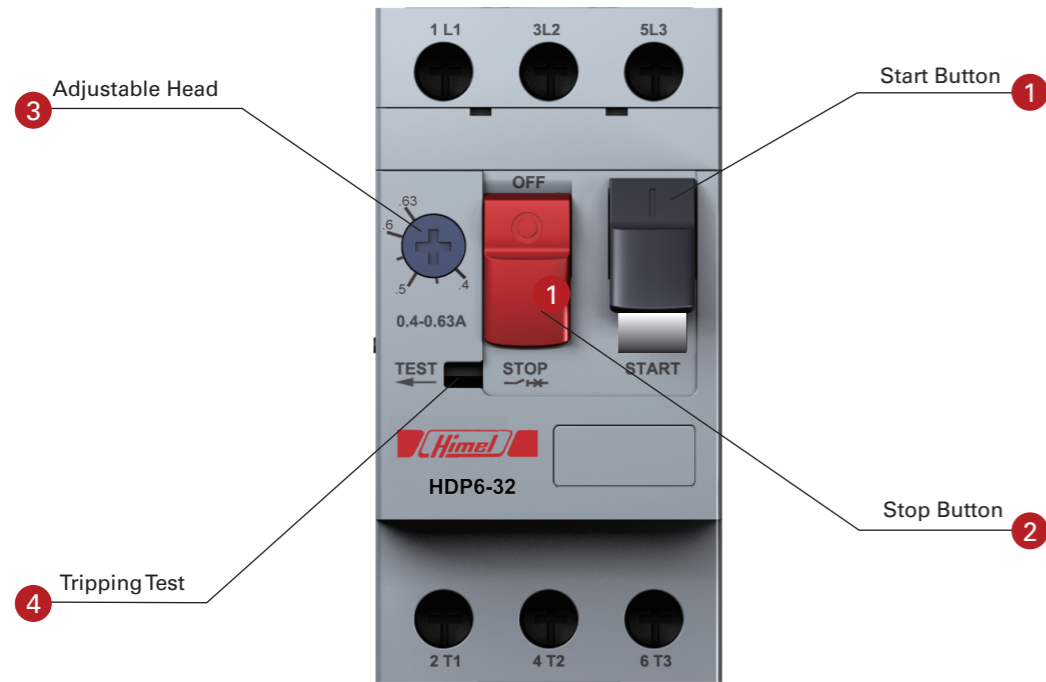

1 Start Button

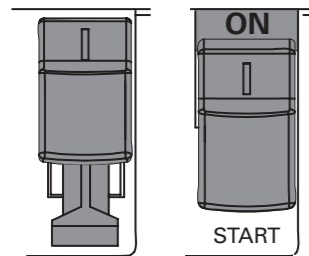

- Press to start HDP6
- After downward pull-out, lock the start button to stop the work

2 Stop Button

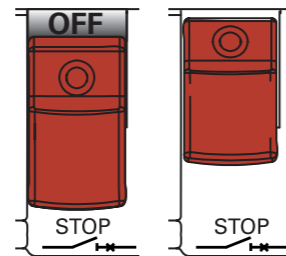

- Press to stop HDP6

3 Adjustable Head



- Set the thermal tripping current

4 Tripping Test



- Can simulate the tripping action, test product performance

HDP6 Motor Circuit Breakers

Standard: IEC60947-4



Breaking Capacity

Setting Current	Ue:230/240V		Ue:400/415V		Ue:440V		Ue:500V		Ue:690V	
	Icu	Ics	Icu	Ics	Icu	Ics	Icu	Ics	Icu	Ics
0.1-0.16A	100kA	100kA	100kA	100kA	100kA	100kA	100kA	100kA	100kA	100kA
0.16-0.25A	100kA	100kA	100kA	100kA	100kA	100kA	100kA	100kA	100kA	100kA
0.25-0.4A	100kA	100kA	100kA	100kA	100kA	100kA	100kA	100kA	100kA	100kA
0.4-0.63A	100kA	100kA	100kA	100kA	100kA	100kA	100kA	100kA	100kA	100kA
0.63-1A	100kA	100kA	100kA	100kA	100kA	100kA	100kA	100kA	100kA	100kA
1-1.6A	100kA	100kA	100kA	100kA	100kA	100kA	100kA	100kA	100kA	100kA
1.6-2.5A	100kA	100kA	100kA	100kA	100kA	100kA	100kA	100kA	3kA	2.25kA
2.5-4A	100kA	100kA	100kA	100kA	100kA	100kA	100kA	100kA	3kA	2.25kA
4-6.3A	100kA	100kA	100kA	100kA	50kA	50kA	50kA	50kA	3kA	2.25kA
6-10A	100kA	100kA	100kA	100kA	15kA	15kA	10kA	10kA	3kA	2.25kA
9-14A	100kA	100kA	15kA	7.5kA	8kA	4kA	6kA	4.5kA	3kA	2.25kA
13-18A	100kA	100kA	15kA	7.5kA	8kA	4kA	6kA	4.5kA	3kA	2.25kA
17-23A	50kA	50kA	15kA	6kA	6kA	3kA	4kA	3kA	3kA	2.25kA
20-25A	50kA	50kA	15kA	6kA	6kA	3kA	4kA	3kA	3kA	2.25kA
24-32A	50kA	50kA	10kA	5kA	6kA	3kA	4kA	3kA	3kA	2.25kA

Remark: Icu Rated Ultimate Short-circuit Breaking Capacity
Ics Rated Service Short-circuit Breaking Capacity

Main Technical Parameters

Fuse gL/gG (When the prospective short-circuit current is greater than the rated ultimate short-circuit breaking capacity Icu, need a spare fuse)

Setting Current	Ue: 230/240V	Ue: 400/415V	Ue: 690V
0.1-0.16A	-	-	-
0.16-0.25A	-	-	-
0.25-0.4A	-	-	-
0.4-0.63A	-	-	-
0.63-1A	-	-	-
1-1.6A	-	-	-
1.6-2.5A	-	-	20
2.5-4A	-	-	32
4-6.3A	-	-	40
6-10A	-	-	40
9-14A	-	80	50
13-18A	-	80	50
17-23A	100	100	50
20-25A	100	100	50
24-32A	100	100	50

Note: '-' no need to use fuse

MOTOR MANAGEMENT

HDP6 Motor Circuit Breakers

Standard: IEC60947-4



3 Phase Motor Rated Power, 50/60Hz, AC-3			
Setting Current	Ue: 230/240V	Ue: 400/415V	Ue: 690V
0.1-0.16A	-	-	-
0.16-0.25A	-	0.06kw	-
0.25-0.4A	-	0.09kw	-
0.4-0.63A	-	0.12kw	0.37kw
0.63-1A	-	0.25kw	0.55kw
1-1.6A	-	0.37kw	1.1kw
1.6-2.5A	0.37kw	0.75kw	1.5kw
2.5-4A	0.75kw	1.5kw	3kw
4-6.3A	1.1kw	2.2kw	4kw
6-10A	2.2kw	4kw	7.5kw
9-14A	3kw	5.5kw	9kw
13-18A	4kw	7.5kw	11kw
17-23A	5.5kw	9kw	15kw
20-25A	5.5kw	11kw	18.5kw
24-32A	7.5kw	15kw	22kw

Order Information

Thermal release Setting current	Magnetic release Current Id	400/415V, 50/60Hz, AC-3 Rated operating power	Recommended Contactor	Reference
0.1-0.16A	1.5A	-	HDC3-0911	HDP632P16
0.16-0.25A	2.4A	0.06kW	HDC3-0911	HDP632P25
0.25-0.4A	5A	0.09kW	HDC3-0911	HDP632P4
0.4-0.63A	8A	0.12kW	HDC3-0911	HDP632P63
0.63-1A	13A	0.25kW	HDC3-0911	HDP6321
1-1.6A	22.5A	0.37kW	HDC3-0911	HDP6321P6
1.6-2.5A	33.5A	0.75kW	HDC3-0911	HDP6322P5
2.5-4A	51A	1.5kW	HDC3-0911	HDP6324
4-6.3A	78A	2.2kW	HDC3-0911	HDP6326P3
6-10A	138A	4kW	HDC3-0911	HDP63210
9-14A	170A	5.5kW	HDC3-1211	HDP63214
13-18A	223A	7.5kW	HDC3-1811	HDP63218
17-23A	327A	9kW	HDC3-2511	HDP63223
20-25A	327A	11kW	HDC3-2511	HDP63225
24-32A	416A	15kW	HDC3-3211	HDP63232
25-40A	480A	16kW	HDC3-4011	HDP17K8040
40-63A	756A	20kW	HDC3-6511	HDP17K8065
56-80A	960A	25kW	HDC3-8011	HDP17K8080

MOTOR MANAGEMENT

HDP6 Motor Circuit Breakers

Standard: IEC60947-4



Accessories

HDP-32 Accessories				
Name	Type	Spec.	Reference	
Undervoltage Release	HAU	110~115V,50Hz;110~127V,60Hz	HAU110	
		220~240V,50/60Hz	HAU220	
		380~400V,50Hz;380~440V,60Hz	HAU380	
		415V,50/60Hz	HAU415	
Shunt Release	HAS	110~115V,50Hz;110~127V,60Hz	HAS110	
		220~240V,50/60Hz	HAS220	
		380~400V,50Hz;380~440V,60Hz	HAS380	
		415V,50/60Hz	HAS415	
Auxiliary Contact	Top	HAE	2NO	HAE20
			1NC+1NO	HAE11
	Side	HAN	2NO	HAN20
			1NC+1NO	HAN11
Auxiliary Contact	Side	HAN	2NO	HDP17Z80A02
			1NC+1NO	HDP17Z80A01

HDP17Z-80 Accessories				
Name	Type	Spec.	Reference	
Auxiliary Contact	Side	HAN	2NO	HDP17Z80A02
			1NC+1NO	HDP17Z80A01

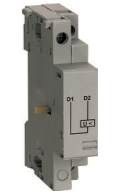

Installation of HAE11 or HAE20

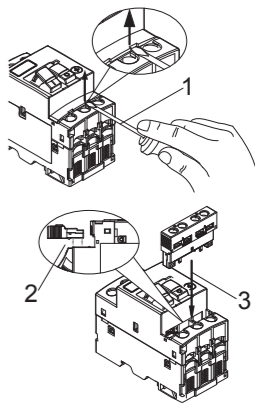

1. Pry the top auxiliary protective cover up;
2. Put the flat surface of the top auxiliary contact close to the circuit breaker;
3. Align the installation position and insert it.

Parameters of instantaneous auxiliary contact

Name	Rated Insulation Voltage Ui	Utilization Category	Rated Operating Voltage	Rated Operating Current	Conventional Thermal Current	
Top Auxiliary Contact	250V	AC-15	24V	2A	2.5A	
			48V	1.25A	2.5A	
			110V	1A	2.5A	
			230V	0.5A	2.5A	
			DC-13	24V	1A	2.5A
				48V	0.3A	2.5A
Side Auxiliary Contact	690V	AC-15	48V	6A	6A	
			110V	4.5A	6A	
			230V	3.3A	6A	
			380V	2.2A	6A	
			DC-13	24V	6A	6A
				48V	5A	6A
			220V	0.5A	6A	

HDP6 Motor Circuit Breakers

Standard: IEC60947-4



Operating Characteristics

No.	Multiples of Current Setting	Tripping time	Initial Conditions	Reference Ambient Air Temperature
Tripping Characteristics for Phase Load Balance				
1	1.05	Non-tripping within 2h	Cold State	+20°C
2	1.2	Tripping within 2h	Immediately after No.1 test	+20°C
3	1.5	Tripping within 2m	Immediately after No.1 test	+20°C
4	7.2	Tripping within 2s $T_p \le 10s$	Cold State	+20°C
Tripping Characteristics for Phase Load Unbalance (Phase Failure)				
	Any 2-Phase	3 rd Phase		
1	1.0	0.9	Non-tripping within 2h	Cold State
2	1.15	0	Tripping within 2h	Immediately after No.1 test
The temperature compensation performance				
1	1.0	Non-tripping within 2h	Cold State	+40°C
2	1.2	Tripping within 2h	Immediately after No.1 test	+40°C
3	1.05	Non-tripping within 2h	Cold State	-5°C
4	1.3	Tripping within 2h	Immediately after No.3 test	-5°C

Thermal Tripping Curve

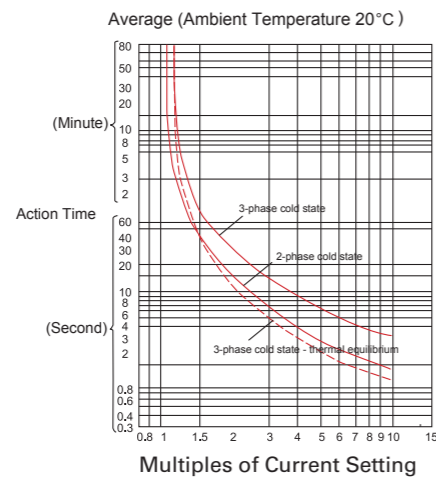

Wiring Diagram

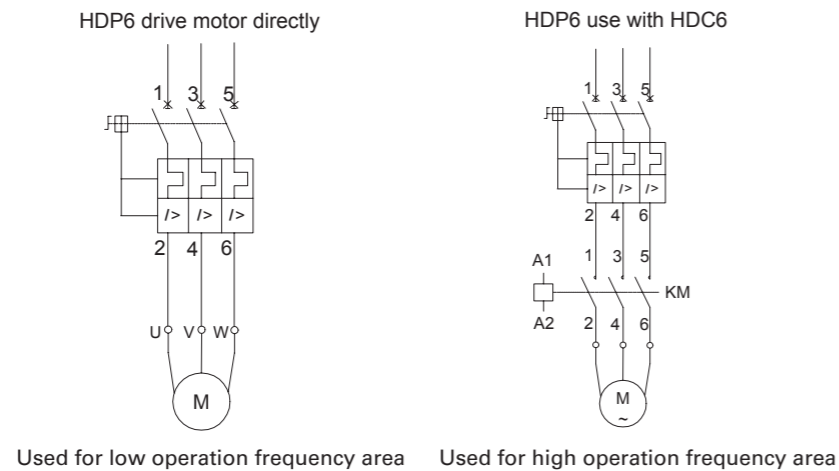

HDP6 Motor Circuit Breakers

Standard: IEC60947-4



Overall Dimension for Installation

HDP6-32

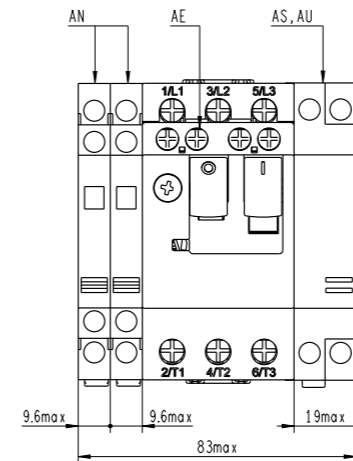
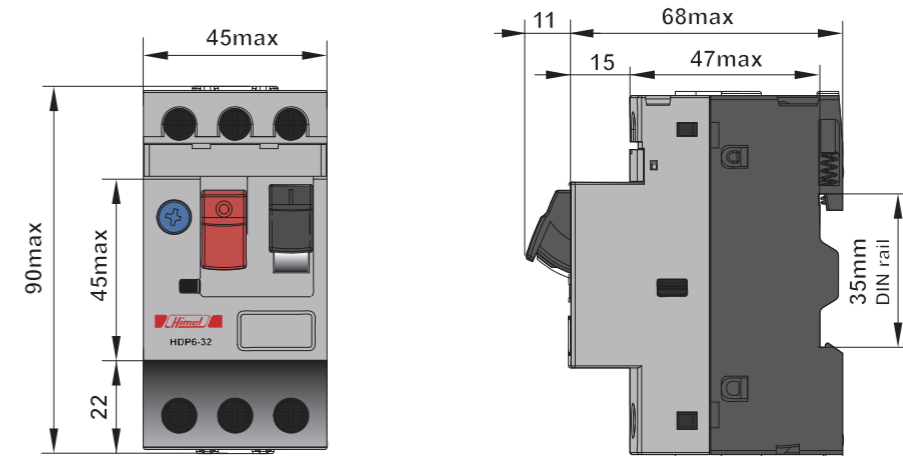

HDP17Z-80

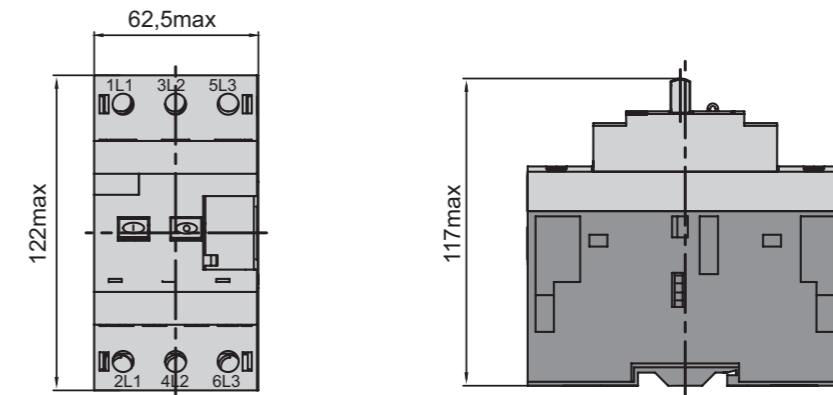

HDS3 Magnetic Starters

Standard: IEC60947-4



Range Presentation

HDS3 is Himel 3 series range of Magnetic Starter mainly used for AC 50/60Hz control system and maximum rated working voltage up to 660V. Direct start and stop of three-phase squirrel cage induction motor with maximum rated working current up to 95A under AC-3 using type, and overload protection is provided for the motor.

Features

- ◆ Frame size 38 with plastic housing
- ◆ Frame size 18/38/95 with metal housing
- ◆ IP54 Protection level
- ◆ With HDC3 series contactor and HDR3s series thermal relay

Online Content



HDS3

Selection Code

Range name	Frame size	Operation type	Rated current	Coil voltage	Coil frequency	Thermal relay	Housing
HDS3	38	B	09	M	7	P16	
HDS3	18: 18A 38: 38A 95: 95A	B: with push button	09: 9A 95: 95A	C: 36V F: 110V S: 127V M: 220/230V Q: 380/400V L: 415V X: 440V	7: 50/60Hz	P16: 0.1-0.16A 1P6: 1.0-1.6 A 93: 80-93A	Default: Plastic M: Metal

Technical Parameters

Magnetic Starters	HDS3-18 Metal			HDS3-38 Metal			HDS3-95 Metal				
	HDS3-38 Plastic										
Rated operating current (Ie) AC-3	9A	12A	18A	25A	32A	38A	40A	50A	65A	80A	95A
Maximum motor power kW (AC-3,380V)	4	5.5	7.5	11	15	18.5	18.5	22	30	37	45
Horse power hp (AC-3,380V)	5.4	7.4	10.1	20.1	24.8	40.2	40.2	44.2	49.6	60.4	60.4
Mechanical endurance 10 thousand times	1200			1000			900		650		
Electrical endurance AC-3 10 thousand times	110			90			65				
Operation frequency AC-3 time/h	1200			600							
Rated insulation voltage (Ui)	690V										
Rated operating voltage (Ue)	240V, 380V/400V, 440V, 660V										
Rated control circuit voltage (Uc)	36V, 110V, 127V, 220/230, 380/400, 415V, 440V										
Coil frequency	50/60Hz										
Operation type	With Pushbutton										
IP grade	IP54										
Certificate	CE, SEMKO										
Standard	IEC 60947-4-1										
Environmental requirement	Altitude	2000m									
	Ambient temperature	-5°C~+40°C									
	Storage temperature	-25°C~+70°C									
	Installation position	The inclination to the vertical plane does not exceed ±5°									
	Rated withstand voltage	6kV									
Humidity requirement	The atmospheric relative humidity does not exceed 50% when the highest ambient temperature is +40°C. It is allowed to have a higher humidity under lower temperature, e.g. up to 90% at +25°C and the dew on the product due to the temperature change should be taken into consideration.										
Installation condition	a. In a medium where is no explosion danger, and the medium has no place where can corrode metal and damage insulated gas and conductive dust; b. In a place where has snow-proof equipment and lack of water vapour; c. In a place without significant shock and vibration.										

HDS3 Magnetic Starters

Standard: IEC60947-4



Order Information

Motor power pe (KW, AC-3, 380V)	Rated current (A)	Frame size		Setting current (A)		AC Contactor type	Thermal overload relay type	Order reference with pushbutton
		HDS3		Range	Code	HDC3	HDR3s	
0.37 0.75 1.5 2.2 3 4 5.5 7.5 11 15 18.5 22 30 37 45	9	HDS3-18 Metallic		0.1~0.16	P16	HDC3-9A	HDR3s-25	HDS318B09*7P16M /HDS338B09*7P16
				0.16~0.25	P25			HDS318B09*7P25M /HDS338B09*7P25
				0.25~0.4	P4			HDS318B09*7P4M /HDS338B09*7P4
				0.4~0.63	P63			HDS318B09*7P63M /HDS338B09*7P63
				0.63~1	1			HDS318B09*701M /HDS338B09*701
				1~1.6	1P6			HDS318B09*71P6M /HDS338B09*71P6
	12	HDS3-38 Plastic		1.6~2.5	2P5	HDS318B09*72P5M /HDS338B09*72P5		
				2.5~4	4	HDS318B09*704M /HDS338B09*704		
				4~6	6	HDS318B09*706M /HDS338B09*706		
				5.5~8	8	HDS318B09*708M /HDS338B09*708		
				7~10	10	HDC3-12A		
				9~13	13	HDC3-18A		
25	HDS3-38 Metallic		12~18	18	HDC3-25A			
			17~25	25	HDS338B25*725M /HDS338B25*725			
			23~32	32	HDC3-32A			
			30~40	38	HDC3-38A			
			32	HDS3-95 Metallic		30~40	40	HDC3-40A
						37~50	50	HDC3-50A
38	HDS3-95 Metallic		48~65	65	HDC3-65A			
			63~80	80	HDC3-80A			
40	HDS3-95 Metallic		80~93	93	HDC3-95A			
38	HDS3-95 Metallic					HDR3s-3	HDS338B32*732M /HDS338B32*732	
							HDS338B38*740M /HDS338B38*740	
							HDS395B40*740	
							HDS395B50*750	
40	HDS3-95 Metallic					HDR3s-93	HDS395B65*765	
							HDS395B80*780	
							HDS395B80*780	
							HDS395B95*793	

HDS3 Magnetic Starters

Standard: IEC60947-4



HDS3 Magnetic Starter is mainly used for control AC 50/60 Hz and maximum rated working voltage in up to 660V. Direct start and stop of three-phase squirrel cage induction motor with maximum rated working current is up to 95A under AC-3 using type, and over protection is provided for the motor.



HDS3 Magnetic Starters

Standard: IEC60947-4



Overall Dimension of Installation (mm)

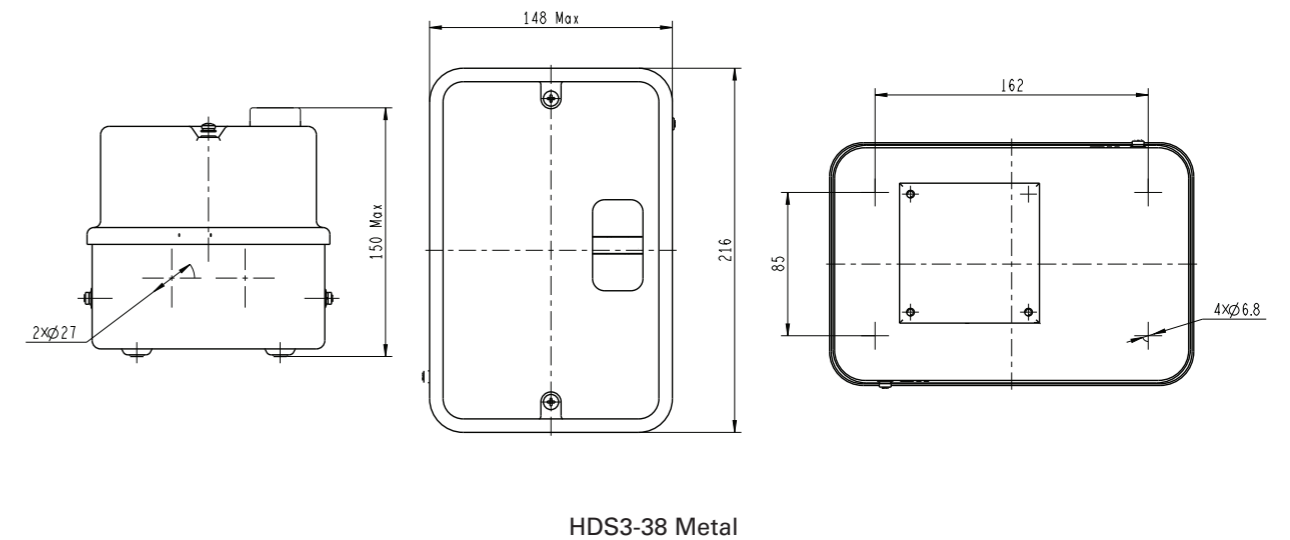
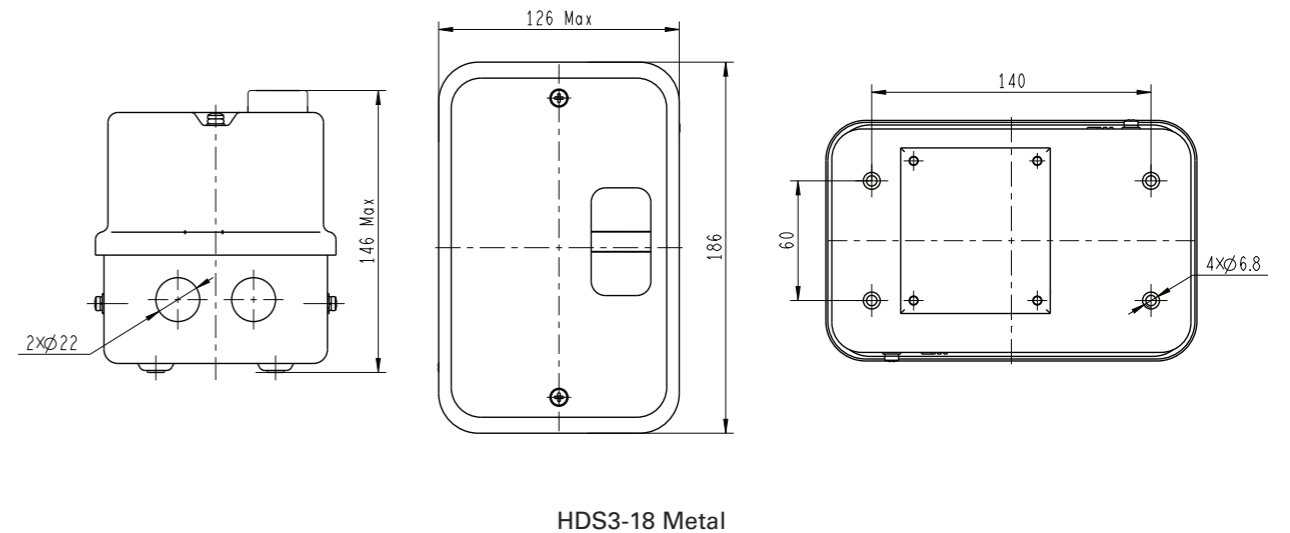

38 frame – Plastic housing

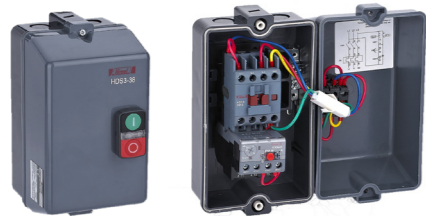

Rated Insolation Voltage (Ui)	690V
Rated Operating Voltage (Ue)	240V, 380V/400V, 440V, 660V
Rated Control Circuit Voltage (Uc)	36V, 110V, 127V, 220/230, 380/400, 415V, 440V
Coil Frequency	50/60Hz
Operation Type	With Pushbutton
IP Grade	IP54
Certification	CE
Standard	IEC 60947-4-1

18/38/95 frame – Metal housing

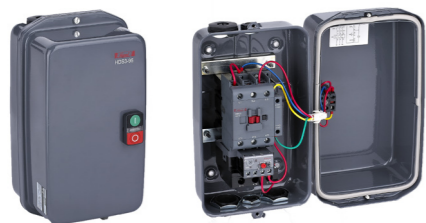

- IP54 Protection level ;
- With better contactor
- and better thermal relay ;
- Better performance ;
- More reliable ;
- RoHS2.0, CE

HDS3 Magnetic Starters

Standard: IEC60947-4



Overall Dimension of Installation (mm)

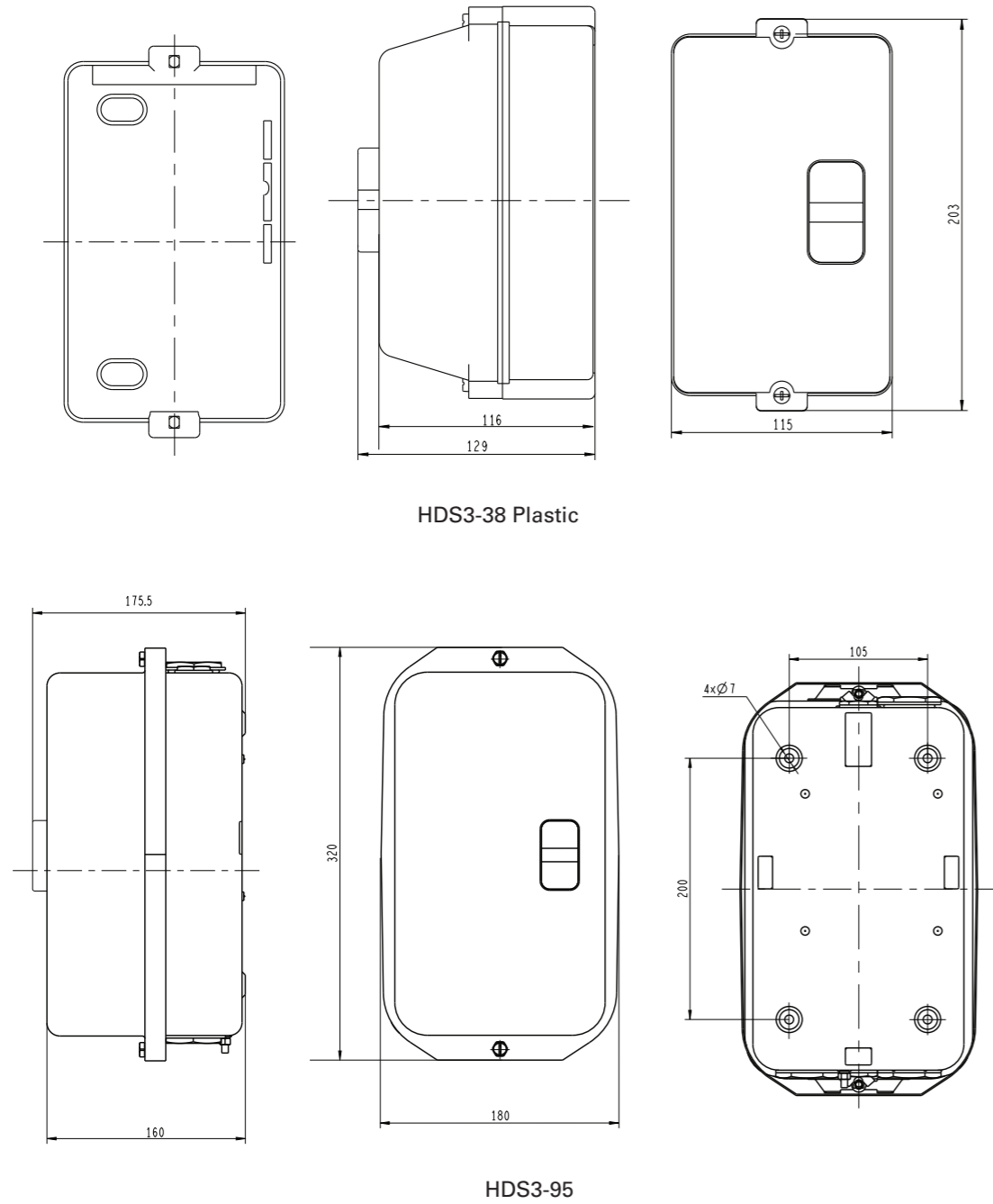

HDS3 Magnetic Starters

Standard: IEC60947-4



Wiring Diagram

