

User Manual for HDB3LT Residual Current Circuit Breaker

- Please carefully read this User Manual before installing and operating the product, and keep it properly for further reference.

Safety Precaution

Please carefully read this manual before the installation, operation, run, maintenance, and inspection of the product, and install and operate the product properly by this manual.



Danger:

- Do not operate the circuit breaker with wet hands;
- Do not touch the live part during operation;
- De-energize the product during maintenance and service;
- Do not use the short circuit way to test the product;



Caution:

- The qualified profession is employed to carry out the installation, maintenance, and service;
- All characteristics of the product have been set in the factory, and cannot be removed or adjusted without permission during operation;
- Please confirm that the rated voltage, rated current, frequency, and characteristics of the product meet the working requirements;
- When wiring, the incoming line shall be connected to the above part and the outgoing line is connected out of the lower; tighten the wiring screw after the wire inserts into the wiring hole; the wire tightening torque is 2.0N•m for the incoming terminal wiring frame, and 1.2N•m for outgoing terminal wiring frame to prevent the wire from loosening or being pulled out. The exposed copper wire end cannot be exposed outside the wiring terminal.
- This product is not suitable for the protection of the electric shock hazard caused by contacting the phase line and neutral line of the protected circuit simultaneously and by contacting the phase line of the protected circuit in the event of the open phase of the neutral line at the incoming terminal;
- With the protection grade IP20, this product has no dustproof function. Therefore, please install this product in a well-sealed terminal box on any dusty occasion;
- If found damaged or abnormal sound when unpacking, please stop the operation of the product immediately and contact the dealer;
- After the disconnection of the product due to electric leakage protection, overload protection, or short circuit protection, first, eliminate the fault and then power on to prevent affecting the service life of the product;
- After installation, do not use the insulation resistance megger tester to measure the insulation resistance between the phase line and the neutral line of the protected line of the product;
- Prevent the product from rain invasion or falling off during the operation, storage, or transport of the product;
- Please dispose of the product wastes when scrapping, and thanks for your cooperation.

Table of Contents

1 Main purpose and scope of application.....	1
2 Introduction to product panel.....	1
3 Normal operation, installation, and transport conditions	2
3.1 Operation and installation conditions	2
3.2 Storage and transport conditions.....	2
4 Technical features.....	2
4.1 Basic specifications and parameters	2
4.2 Rated residual making and breaking capacity.....	3
4.3 Overcurrent trip characteristics.....	3
4.4 Structure feature and working principle.....	3
5 Outline and installation dimensions.....	4
6 Installation and operation (maintenance).....	4
6.1 Installation	4
6.2 Maintenance and service.....	5
6.3 Troubleshooting and solutions.....	6
7 Unpacking inspection	6
8 Company's commitments	6

1 Main purpose and scope of application

HDB3LT residual current circuit breaker is primarily used in an AC 50Hz/60Hz circuit with rated operating voltage 230V/240V and with rated current 6A~50A for short-circuit protection, and used in a power distribution line with rated run short circuit breaking capacity of not greater than 10000A for overload protection and residual current protection as well as for isolation and control, suitable for many fields such as industry, civil residence, and commercial building.

2 Introduction to product panel

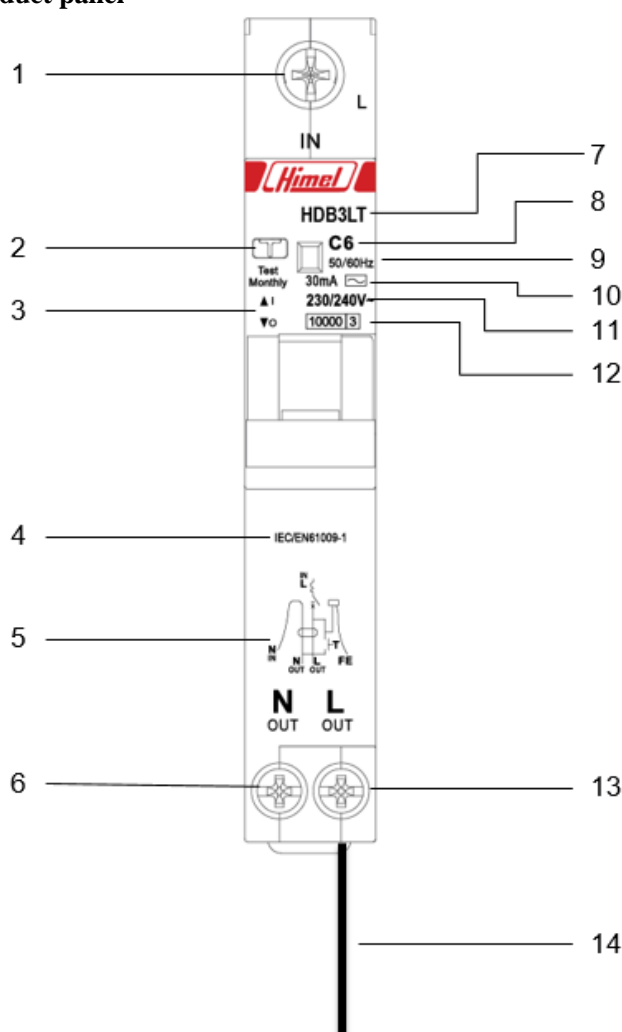

Legends:

1. Incoming terminal of L pole, 2. Test button, 3. Switch ON indicator, 4. Reference standard, 5. Wiring diagram, 6. The outgoing terminal of N pole, 7. Product model, 8. Trip curve and rated current, 9. Rated freq., 10. Rated residual action current, 11. Rated voltage, 12. Rated breaking capacity, 13. Outgoing terminal of L pole, 14. Incoming terminal and ground wire of N pole

3 Normal operation, installation, and transport conditions

3.1 Operation and installation conditions

- a) The upper limit of ambient air temperature does not exceed +60°C, and the lower limit is not below -20°C; the mean temperature does not exceed +35°C within 24 hours;

- b) The altitude of the installation site does not exceed 2000m;
- c) When the temperature is +60°C, the relative humidity of air does not exceed 50%; a large relative humidity is allowed at a lower temperature. For example, the relative humidity does not exceed 90% when at +20°C. Protective measures shall be taken for condensation occurred occasionally due to temperature changes;
- d) The external magnetic field nearby the circuit breaker installation site shall not exceed 5 times the geomagnetic field in any direction;
- e) The product shall be installed in a medium without any explosion risk free of gas or dust enough to cause corrosion to the metal or damage to the insulation, and the installation position shall be vertical and the inclination shall not exceed 10° in any direction;
- f) Installed in a place free of obvious impact vibration or rain and snow invasion;
- g) Grounding method: Connected via the column terminal.
- h) Pollution level: Level 2
- i) Protection grade: IP20 (IP40 when installed in a distribution box, power distribution cabinet, or box)
- j) Installation category: Class II and III

3.2 Storage and transport conditions

- a) The lower temperature limit is not below -40°C, and the upper limit does not exceed +70°C;
- b) The relative humidity (at 25°C) does not exceed 95%;
- c) Please handle the product gently during transport, and do not upside it down to prevent a violent collision.

4 Technical features

4.1 Basic specifications and parameters see Table 1

Table 1 Residual current action characteristics

Rated voltage (V)	Rated current In (A)	Rated residual action current I Δ n (mA)	Rated residual non-action current I Δ no (mA)	Max. breaking time (s)			Rated short-circuit capacity (Icn) and run short-circuit capacity (Ics)			
				I Δ n	2I Δ n	5I Δ n	Rated short-circuit capacity	Power factor COS Φ	Run short-circuit capacity	Power factor COS Φ
AC230/240	6,10,16,20,25,32,40,50	10	5	0.1	0.1	0.04	10000	0.45~0.5	7500	0.45~0.5
		30	15							
		100	50							
		300	150							

4.2 Rated residual making and breaking capacity (I Δ m)

Table 2 Rated residual making and breaking capacity

Rated current (A)	Rated operating voltage (V)	Rated residual making and breaking capacity (I Δ m)	
		Rated breaking capacity	Power factor COS Φ

6~50	AC230/240	7500A	0.45~0.5
------	-----------	-------	----------

4.3 Overcurrent trip characteristics

The overcurrent trip characteristics of the residual current circuit breaker in the normal installation conditions when the reference ambient temperature range is maintained at 30°C to 35°C shall comply with Table 3.

Table 3 Overcurrent release protection characteristics

Type	Test current (A)	Start state	Test time T	Test result	Remarks
B, C	1.13I _n	Cold state	≥1h	No trip	
B, C	1.45I _n	Hot state	<1h	Trip	The current rises to a specified value stably within 5s
B, C	2.55I _n	Cold state	1~60s (I _n ≤32A)	Trip	
			60~120s (I _n >32A)		
B C	3I _n 5I _n	Cold state	≥0.1s	No trip	Turn on the auxiliary switch for power-on
B C	5I _n 10I _n	Cold state	<0.1s	Trip	Turn on the auxiliary switch for power-on

Other technical parameters

- a) Mechanical life: 20000 times
- b) Electrical life: 10000 times

4.4 Structure feature and working principle

The residual current action circuit breaker is primarily composed of a zero-sequence current transformer, an electronic board, a release, a contact operating mechanism, and plastic housing.

The working principle is shown in Fig. 1. In the event of an electric leakage or personal electric shock in the circuit, a signal (induced voltage) is generated from the secondary coil of the zero-sequence current transformer. When the residual action current reaches the action current set value and is enlarged through the electronic line to make the residual current action circuit breaker break to cut off the power for electric leakage protection.

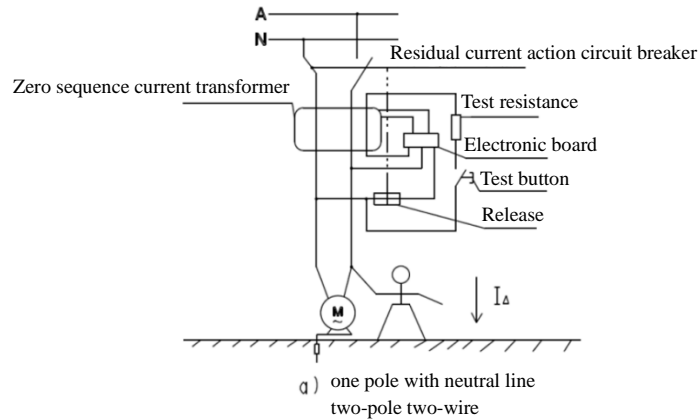

Fig. 1 Schematic diagram of residual current action circuit breaker

5 Outline and installation dimensions

Outline and installation dimensions see Fig. 2

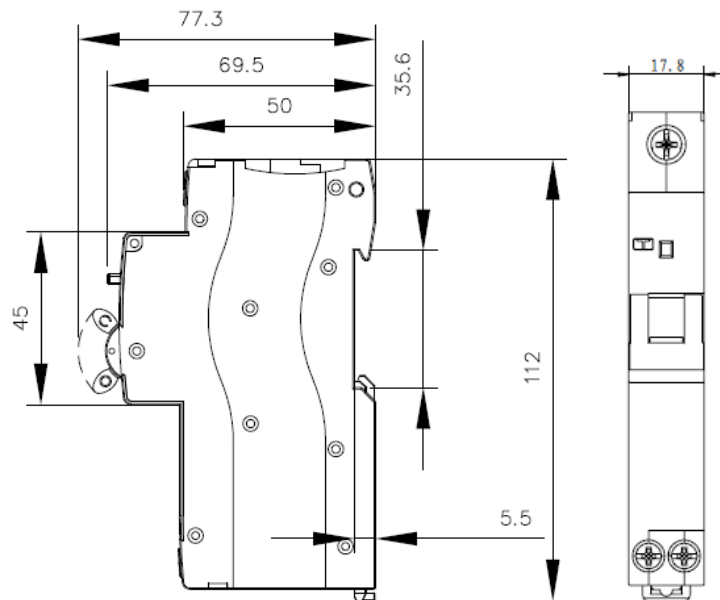

Fig. 2 Outline and installation dimensions

6 Installation and operation (maintenance)

6.1 Installation

- Check whether the product identification is consistent with the used conditions before installation;
- Press the Reset button before power-on;
- Operate the residual current action circuit breaker several times before power-on and check whether the mechanism can work flexibly and reliably without any blockage;
- The incoming terminal shall be connected to the power supply, and the load terminal is connected to the load;
- The **sectional area** of the connected conductor adapts to the rated current of **a** circuit breaker, as shown in Table 4.

Table 4 Correspondence relation between the sectional area of the connected conductor and the rated current of the circuit breaker

Rated current A	6	8, 10	13, 16, 20	25	32	40, 50
The sectional area of wire mm ²	1	1.5	2.5	4	6	10
Wire tightening torque N•m	2.0N•m for incoming terminal wiring frame; 1.2N•m for outgoing terminal wiring frame					

- f) Operate the test button of the residual current action circuit breaker intermittently several times after power-on and check whether the button can work reliably;
- g) The handle moving upwards indicates that the circuit is in the ON state, and the handle moving downwards indicates that the circuit is in the OFF state.
- h) Insert the residual current action circuit breaker into the mounting rail when installation and fix the residual current action circuit breaker onto the rail without any looseness and falling off. To remove the residual current action circuit breaker, push it upwards forcedly, and pull the upper part of the residual current action circuit breaker to dismantle it from the mounting rail.
- i) The reference operating temperature of the residual current action circuit breaker is +30⁺⁵°C. When the ambient temperature changes, its rated value shall be corrected, and the temperature correction coefficient, see Table 5; when multiple residual current action circuit breakers are installed in a closed tank, the temperature inside the tank will rise, and the rated current shall multiply by deteriorating coefficient 0.8.

Table 5 Rated current and temperature correction coefficient table

Rated current A	Rated current corrected value A								
	-20°C	-10°C	0°C	10°C	20°C	30°C	40°C	50°C	60°C
6	7.33	7.05	6.84	6.62	6.30	6	5.64	5.42	5.06
8	9.78	9.44	9.15	8.51	7.98	8	7.1	6.92	6.75
10	12.25	11.87	11.64	11.15	10.62	10	9.30	8.96	8.48
13	15.78	15.34	14.83	14.22	13.75	13	12.10	11.75	10.93
16	19.49	18.72	18.06	17.98	16.96	16	15.04	14.42	13.47
20	24.35	23.68	22.82	22.47	21.20	20	18.80	17.85	16.78
25	30.52	29.61	28.78	28.09	26.50	25	23.25	22.52	21.02
32	38.96	37.68	36.62	35.96	33.92	32	30.08	28.81	26.84
40	48.85	47.13	46.32	45.80	42.80	40	36.80	36.21	33.5
50	61.58	59.52	57.35	55.04	52.59	50	46	44.25	42.36

6.2 Maintenance and service

- a) Maintenance and service must be carried out by a qualified professional;
- b) Make sure the product is de-energized;
- c) The product shall be maintained and serviced once under the normal operation conditions, and the maintenance contents see Table 5;
- d) The residual current action circuit breaker shall be checked regularly (monthly) after operation for some time. Press the test button and check whether the residual current action circuit breaker can work

reliably at the power-on state. If not work normally, please stop it for replacement immediately.

Table 5 Maintenance and service

Item	Content
Appearance	No dust or condensation; clean it if necessary No damaged The housing and wiring terminal is not discolored
Connection of wiring terminal	Tighten it according to the torque listed in Table 3 without any looseness
Handle ON/OFF operation	Flexible operated

6.3 Troubleshooting and solutions

The troubleshooting and solutions of the residual current action circuit breaker see Table 6

Table 6 Troubleshooting and solutions

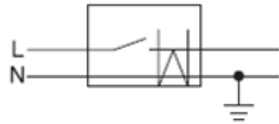
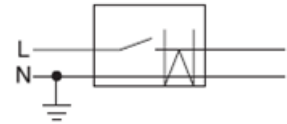
Fault		Cause	Solution
Misoperation	Misoperated by the grounding of the neutral line of the load side of residual current action circuit breaker	<p>The grounding of the neutral line of the load side of the residual current action circuit breaker will make the normal operating current flows in via the grounding point causing misoperation.</p> <p>Residual current action circuit breaker</p>  <p>Incorrect wiring</p>	<p>Connect the ground wire to the neutral line of the power side of the residual current action circuit breaker</p> <p>Residual current action circuit breaker</p>  <p>Correct wiring</p>
	Misoperation of capacitance current due to leakage current and wire	<p>The length of wire tightly laying against the ground at the load side is too long</p> <p>The earth leakage current increases due to the reduction of insulation performance of wire at the load side</p>	<p>Select a residual current action circuit breaker with a slightly large residual action current</p> <p>Replace wire</p>

Failure to operate	Failure to operate due to the residual current action circuit breaker not connected with neutral line	The power side of the residual current action circuit breaker is only connected with the phase line and is not connected with the neutral line	Connect the neutral line at the power side
---------------------------	---	--	--

7 Unpacking inspection

After unpacking, please check whether the product is intact, whether the exposed metal is rusty, or whether the product is defective due to poor transport or storage. If it is found the above phenomenon, do not operate the product anymore, then contact the supplier timely for a solution.

8 Company's commitments

Under the premise that users follow the operation and storage conditions and the product is well sealed, our company will provide repair and replacement service free of charge for any damage or abnormal use due to poor manufacture quality within 36 months from the production date. A paid repair will be provided if the warranty period expires. For any damage caused by one of the following situations, a paid repair will be given even if within the warranty period:

- a) Improper operation, maintenance, or storage;
- b) Modified without permission or improper repair;
- c) Damaged due to falling off or during installation after purchase;
- d) Force majeure such as earthquakes, fires, lightning strikes, abnormal voltages, and secondary disasters;

If you have any questions, please contact our company's dealer or customer service department.

Customer service hotline: xxxxxxxx