

Himel Drives

Smart Pump – HAV SP Series

Variable Speed Drives for Asynchronous Motors

User Manual

07/2022



© 2022 HIMEL



Preface

Thank you for purchasing the HAV-SP series drive developed and produced by Himel

HAV-SP drives are full-featured dedicated drives for parabolic load applications like pumps, fans, and chillers. HAV-SP has a wide range of integrated features like multi-pump control, dry run protection, sensor-less flow and energy calculation, pump cleaning, fire override mode, frost, condensation and hammer effect protections to meet the needs of pump, fans and chillers for modern buildings. HAV-SP also has functions like PID control, simple PLC, multi-speed control and other functions to meet different process requirements.

Before using this drive, the users and relevant technicians shall read this manual carefully to ensure that the drive can be properly installed and operated, so that the drive can perform its best performance.

If there is any change to this user manual, please refer to the new version without notice.

High-performance Drive

User Manual

Version: V1.4

This product implements standards:

The design and production of this product refer to the latest national standards (GB or GB/T), International Electrotechnical Commission Standards (IEC) and International System of Units (SI). The technical parameters of the relevant parts can meet the requirements of national standards (GB or GB/T) and International Electrotechnical Commission Standards (IEC). Main standards:

GB/T 12668.2-2002 Adjustable Speed Electrical Power Drive Systems - Part 2: General Requirements - Rating Specifications for Low Voltage Adjustable Frequency AC Power Drive Systems

GB 12668.3-2012 Adjustable Speed Electrical Power Drive Systems - Part 3: EMC Requirements and Specific Test Methods

GB 12668.501-2013 Adjustable Speed Electrical Power Drive Systems - Part 5: Safety Requirements - Electrical, Thermal and Energy

GB/T 2423.1-2008 Environmental Testing for Electric and Electronic Products - Part 1: Test Methods Tests A: Cold

GB/T 2423.2-2008 Environmental Testing for Electric and Electronic Products - Part 2: Test Methods Tests B: Dry Heat

GB/T 2423.3-2006 Environmental Testing - Part 2: Testing Method - Test Ca: Damp Test, Steady State

GB/T 2423.4-2008 Environmental Testing for Electric and Electronic Products - Part 2: Test method - Test Db: Damp heat, cyclic (12h+12h Cycle)

GB/T 2423.9-2006 Environmental Testing for Electric and Electronic Products - Part 9: Test Methods Tests Cb: Constant damp heat for equipment

GB/T 2423.7-1995 Environmental Testing for Electric and Electronic Products - Part 7: Test Methods Tests Ed: Free Fall

GB/T 2423.22-2012 Environmental Testing for Electric and Electronic Products - Part 2: Test method - Test N: Change of Temperature

GB/T4798.1-2005 Environmental Conditions Existing in the Application of Electric and Electronic Products - Storage

GB/T4798.2-2008 Environmental Conditions Existing in the Application of Electric and Electronic Products - Transport

GB/T4798.3-2007 Environmental Conditions Existing in the Application of Electric and Electronic Products - Work



Danger

The drive must be reliably grounded. If the drive is not reliably grounded, there may be a potential danger of personal injury in the device.

Readers

This user manual is suitable for the following readers.

Drive installers, engineering technicians (electrical engineers, electrical operators, etc.), designers, etc. Please ensure that this user manual reaches the end users.

Notational conventions in this manual



Caution: Moderate or minor injuries may occur due to failure to operate as required.



Danger: Deaths or serious injuries may occur due to failure to operate as required.

Table of Contents

Chapter I Product Specification and Ordering Instructions	6
1.1 Drive series models	6
1.2 Product appearance and installation dimensions	7
1.3 Dimensions of optional base	9
1.4 Keypad size	9
1.5 Installation of remote keypad	11
1.6 Name of each part of this series drives	12
1.7 Braking resistors	13
Chapter II Installation and Wiring of Drive	16
2.1 Drive installation environment	16
2.2. Removal and installation of drive panel	20
2.3 Wiring of main circuit terminals	22
2.4 Control circuit configuration and wiring	26
Chapter III Operation Instructions of Drive	32
3.1 Key function description	32
3.2 Keypad operation methods	32
Chapter IV Function Parameter Table	35
4.1 Function parameter table	35
4.2 Monitoring parameter group U0	97
4.3 Fault record parameter group U1	100
4.4 Fault code summary table	101
Chapter V Basic Operation Instructions	102
5.1 Start operation mode	102
5.2 Start-stop control	105
5.3 Frequency setting	108
5.4 Analog input	110
5.5 Analog output	112

5.6 Digital input	114
5.7 Digital output	119
5.8 Simple PLC	123
5.9 Multistage speed operation	127
5.10 PID control	131
5.11 Multi-pump control	136
5.12 Troubleshooting	144
Appendix I Communication Protocol	151
Appendix II Multi-pump control expansion card applications	156
6.1 Multi-pump control expansion card installation instructions	156
6.2 Multi-pump control expansion card terminal function description	156
6.3 Fault countermeasures and exception handling	157

Chapter I Product Specification and Ordering Instructions

1.1 Drive series models

The input voltage range of this drive is 380V-440VAC and 220V-240V. The adaptive motor power range is 2.2 kW ~ 160 kW. The models of this series drives are shown in Table 1-1.

Table 1-1 Drive Models

Drive model	Rated capacity (kVA)	Rated output current (A)	Adaptable motor (kW)
HAV-SP-4T0022P	3.7	5.0	2.2
HAV-SP-4T0030P	4.9	7.5	3.0
HAV-SP-4T0040P	7.5	8.8	4.0
HAV-SP-4T0055P	8.5	13	5.5
HAV-SP-4T0075P	11	17	7.5
HAV-SP-4T0110P	17	25	11
HAV-SP-4T0150P	21	32	15
HAV-SP-4T0185P	24	37	18.5
HAV-SP-4T0220P	30	45	22
HAV-SP-4T0300P	40	60	30
HAV-SP-4T0370P	50	75	37
HAV-SP-4T0450P	60	90	45
HAV-SP-4T0550P	72	110	55
HAV-SP-4T0750P	100	157	75
HAV-SP-4T0900P	116	180	90
HAV-SP-4T1100P	138	214	110
HAV-SP-4T1320P	167	256	132
HAV-SP-4T1600P	200	307	160
HAV-SP-2T0022P	3.7	10.08	2.2
HAV-SP-2T0030P	4.9	11.5	3.0

Drive model	Rated capacity (kVA)	Rated output current (A)	Adaptable motor (kW)
HAV-SP-2T0040P	7.5	16.2	4.0
HAV-SP-2T0055P	8.5	20.3	5.5
HAV-SP-2T0075P	11	26.7	7.5
HAV-SP-2T0110P	17	39	11
HAV-SP-2T0150P	21	52.5	15
HAV-SP-2T0185P	24	62.4	18.5
HAV-SP-2T0220P	30	73.6	22
HAV-SP-2T0300P	40	98.7	30
HAV-SP-2T0370P	50	121	37
HAV-SP-2T0450P	60	147	45

 Note: If you need models of other power ranges, please consult the manufacturer before ordering!

1.2 Product appearance and installation dimensions

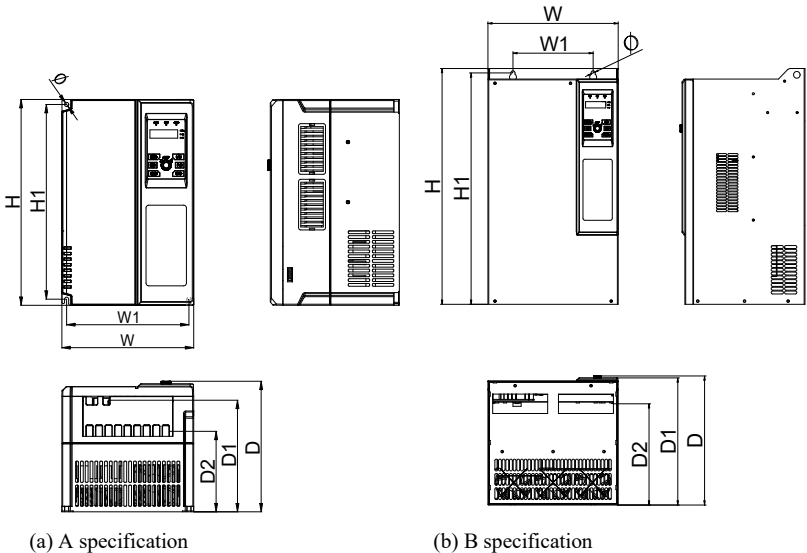
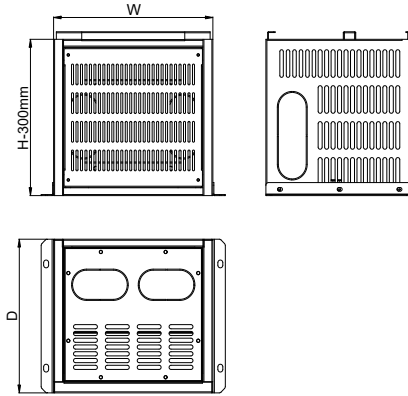

Table 1-2 Drive Appearance and Installation Series Dimensions (Unit: mm)

Drive Model	W	W1	H	H1	D	D1	D2	Mounting hole diameter (Φ)	Reference picture
HAV-SP-4T0022P	120	109	215	204	163	133	85	5.5	(a)
HAV-SP-4T0030P									
HAV-SP-4T0040P									
HAV-SP-4T0055P									
HAV-SP-4T0075P									
HAV-SP-2T0022P									
HAV-SP-2T0030P									
HAV-SP-2T0040P									
HAV-SP-4T0110P	150	138	259	248	181	150	104	5.5	(a)
HAV-SP-4T0150P									
HAV-SP-2T0055P									
HAV-SP-2T0075P									
HAV-SP-4T0185P	205	188	322	305	215	176	130	6.5	(a)
HAV-SP-4T0220P									
HAV-SP-2T0110P									
HAV-SP-4T0300P	235	218	370	350	235	200	146	7	(a)
HAV-SP-4T0370P									
HAV-SP-2T0150P									
HAV-SP-2T0185P									
HAV-SP-4T0450P	305	200	490	470	275	270	211	10	(b)
HAV-SP-4T0550P									
HAV-SP-2T0220P									
HAV-SP-2T0300P									
HAV-SP-4T0750P	320	197	560	543	307	302	240	10	(b)
HAV-SP-4T0900P									
HAV-SP-4T1100P									
HAV-SP-2T0370P									
HAV-SP-2T0450P									
HAV-SP-4T1320P	355	240	678	659	319	314	261	11	(b)
HAV-SP-4T1600P									

Note: 1. The base of HAV-SP-4T0450P~HAV-SP-4T1600P and HAV-SP-2T0220P~HAV-SP-2T0450P are optional.

1.3 Dimensions of optional base



Note: The dimensions of the base in W and D directions are consistent with the corresponding model, as shown in Table 1-2, and the H dimension is fixed at 300mm.

Table 1-3 Base Matching Table

Base jacking model	Adaptable models
HAV-XS-4T0370DZ	HAV-SP-4T0450P~HAV-SP-4T0550P HAV-SP-2T0220P~HAV-SP-2T0300P
HAV-XS-4T0750DZ	HAV-SP-4T0750P~HAV-SP-4T1100P HAV-SP-2T0370P~HAV-SP-2T0450P
HAV-XS-4T1100DZ	HAV-SP-4T1320P~HAV-SP-4T1600P

1.4 Keypad size

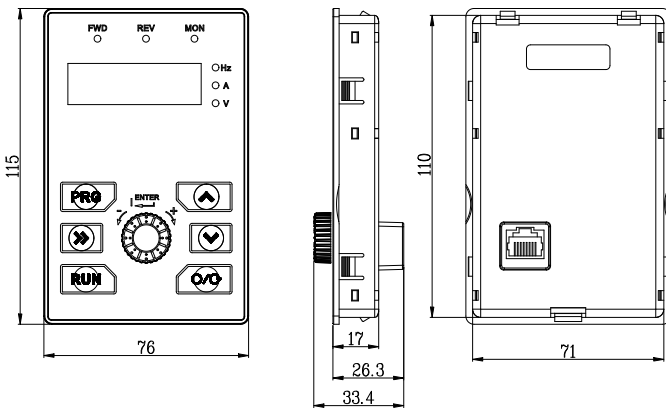

Figure 1-1 Keypad HAV-SP-LKD Size

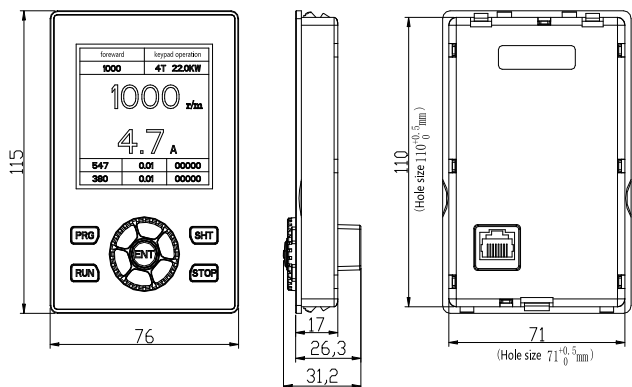

Figure 1-2 Keypad HAV-SP-LCD Size

Table 1-4 Datasheet of HAV-SP-LCD

Item	Description
Display screen size	55*55mm
Display resolution	160*160
Display mode	Blue screen
Keypad interface	RJ45 interface
USB interface	Micro USB
Humidity	Less than 90%RH, no condensation
Vibration	Less than 5.9m/s ²
Environment temperature	-10°C~+50°C
Storage temperature	-40°C~+60°C
Protection class	IP20

1.5 Installation of remote keypad

The remote keypad can be installed in two ways, one is directly installed on an iron plate, and the other is installed on an optional keypad tray.

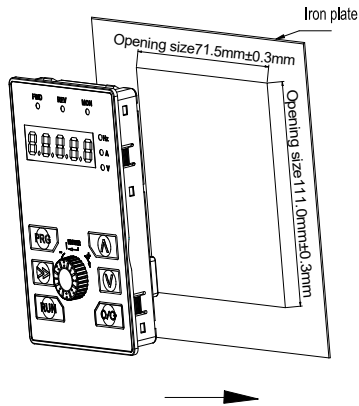

When the remote keypad is installed on an iron plate, the installation process is shown in the figure. Press down the keypad in the direction of the arrow until a "click" sound is heard.

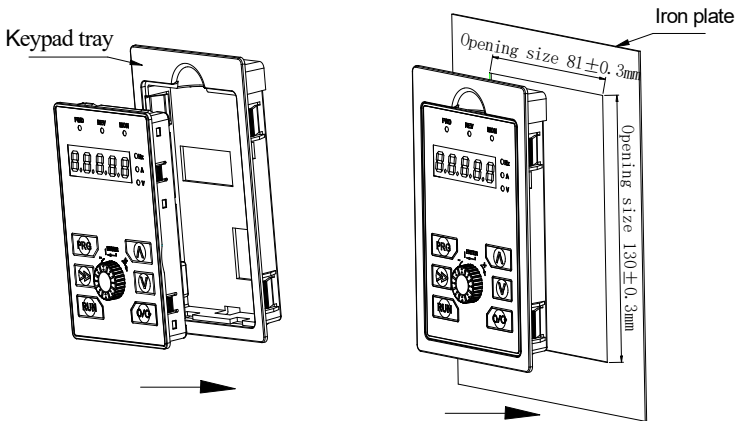

When the remote keypad is installed on an optional keypad tray, the installation process is shown in the figure. Place the keypad into the tray in the direction of the arrow, and press down the entire keypad in the direction of the arrow, until a "click" sound is heard.

1.5.1 Dust-proof sticker for optional parts (schematic diagram of outlet position of outgoing keypad line)

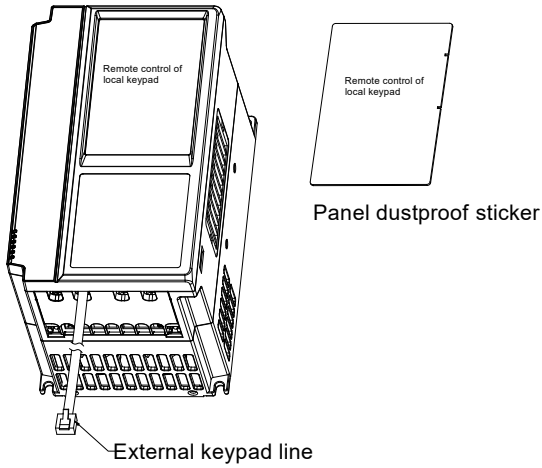

Table 1-5 Dustproof Sticker Model

Dustproof sticker model	Adaptable models
HAV-XS-FCT	HAV-SP-4T0022P~HAV-SP-4T1600P HAV-SP-2T0022P~HAV-SP-2T0450P

1.6 Name of each part of this series drives

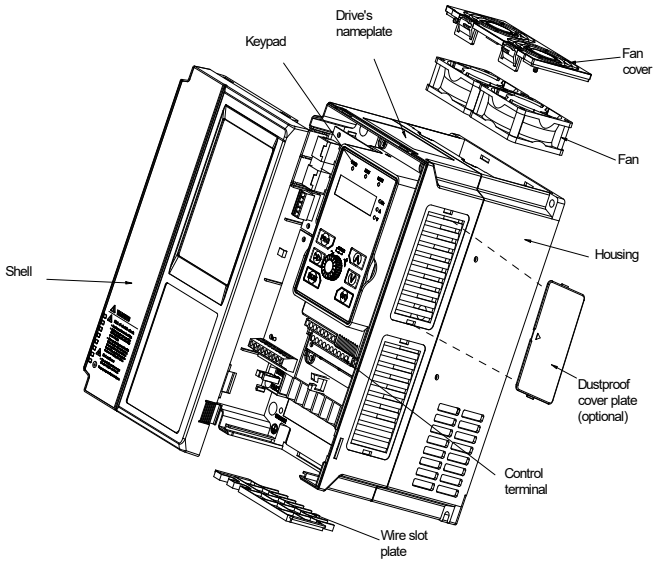

Table 1-6 Dustproof Cover Plate Model

Dustproof cover plate model	Adaptable models
HAV-XS-4T0220 (black)	HAV-SP-4T0022P~HAV-SP-4T0370P HAV-SP-2T0022P~HAV-SP-2T0185P

1.7 Braking resistors

Please select energy consumption braking resistors according to Table 1-6. The wiring of the braking resistors is shown in Figure 1-2.

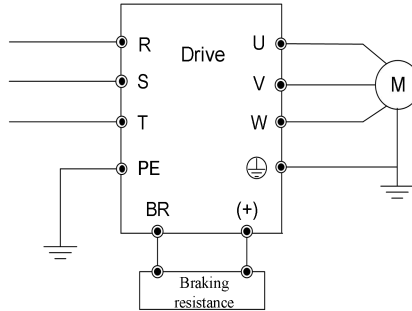

Figure 1-3 Drive and Braking Assembly Wiring Diagram

Note:

1. The power derating of the braking resistor shall not exceed 30%, otherwise there is a risk of fire.
2. For braking standard products of 37kW and below, the built-in braking unit can be used; for braking those of 45kW and above, an external braking unit needs to be added.
3. The wiring length of the braking resistor shall be less than 5m. During the energy consumption braking process, the braking resistor will cause temperature rise due to energy consumption. During installation, pay attention to safety protection and sound ventilation.

The braking resistor resistance and the power are selected according to the actual situation. The greater the system inertia, the shorter the deceleration time required, the more frequent the braking, the greater the power required by the braking resistor and the smaller the resistance required. Table 1-6 is recommended based on general applications.

Table 1-7 Braking Resistor Selection Table (380V)

Specification	Suitable motor power (kW)	Braking resistor recommendation Resistance (Ω)	Braking resistor recommendation Power (W)
HAV-SP-4T0022P	2.2	200	100
HAV-SP-4T0030P	3.0	200	200
HAV-SP-4T0040P	4.0	200	300
HAV-SP-4T0055P	5.5	200	300
HAV-SP-4T0075P	7.5	≥ 80	750
HAV-SP-4T0110P	11	≥ 50	1100
HAV-SP-4T0150P	15	≥ 50	1500
HAV-SP-4T0185P	18.5	≥ 45	1800

Specification	Suitable motor power (kW)	Braking resistor recommendation Resistance (Ω)	Braking resistor recommendation Power (W)
HAV-SP-4T0220P	22	≥ 45	2200
HAV-SP-4T0300P	30	≥ 24	3000
HAV-SP-4T0370P	37	≥ 24	3000

Table 1-8 Braking Resistor Selection Table(220V)

Specification	Suitable motor power (kW)	Braking resistor recommendation Resistance (Ω)	Braking resistor recommendation Power (W)
HAV-SP-2T0022P	2.2	≥ 100	200
HAV-SP-2T0030P	3.0	≥ 75	300
HAV-SP-2T0040P	4.0	≥ 75	300
HAV-SP-2T0055P	5.5	≥ 50	400
HAV-SP-2T0075P	7.5	≥ 45	750
HAV-SP-2T0110P	11	≥ 30	1100
HAV-SP-2T0150P	15	≥ 30	1100
HAV-SP-2T0185P	18.5	≥ 18	1800

1.8 Accessory of HAV-SP

If you need the accessories as follow, please specify when ordering.

Name	Reference	Short Description	Applicable Product
Dust cover	HAV-SP-FCB	Prevent dust from entering the drive	HAV-SP-4T0022P~H AV-SP-4T0370P HAV-SP-2T0022P~H AV-SP-2T0185P
Keypad tray	HAV-SP-JPT	Use when an external keypad is installed	All series
LCD Keypad	HAV-SP-LCD	LCD keypad	All series
Simple IO expansion card	HAV-XS-IO-3DI-R	Expand 3 DI, 1 relay	HAV-SP-4T0022P~H AV-SP-4T1600P HAV-SP-2T0022P~H AV-SP-2T0450P
IO expansion card	HAVSPIO3DI3R	Expand 3 DI, 3 relay	HAV-SP-4T0022P~H AV-SP-4T1600P HAV-SP-2T0022P~H AV-SP-2T0450P
Mounting bracket	HAV-XS-4T*	For embedded installation of drive	*: For detailed model and power matching, please refer to Table 2-2
Mounting base	HAV-XS-4T*	Used for cabinet installation	*: For detailed model and power matching, please refer to Table 1-4
Dustproof sticker	HAV-SP-FCT	Use when an external keypad is installed	All series

Chapter II Installation and Wiring of Drive

2.1 Drive installation environment

2.1.1 Installation environment requirements

- (1) Install in a well-ventilated indoor place. The ambient temperature is required to be within the range of -10°C - 40°C . If the temperature exceeds 40°C , external forced cooling or derating is required.
- (2) Avoid installing in places with direct sunlight, dusty, floating fibers and metal powder.
- (3) Do not install in places with corrosive or explosive gases.
- (4) The humidity is required to be lower than 90%RH, without condensation of water droplets.
- (5) Install in places where the plane fixed vibration is less than 5.9 m/s^2 .
- (6) Try to keep away from electromagnetic interference sources and other electronic instruments and equipment that are sensitive to electromagnetic interference.

2.1.2 Installation direction and space

- (1) Generally, vertical installation shall be adopted.
- (2) Minimum installation intervals and distances are shown in Figure 2-1.
- (3) When multiple drives are installed up and down, the baffle applied in the middle is shown in Figure 2-2.

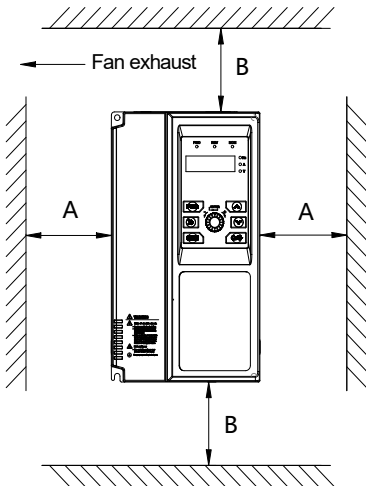

Figure 2-1 Installation Diagram

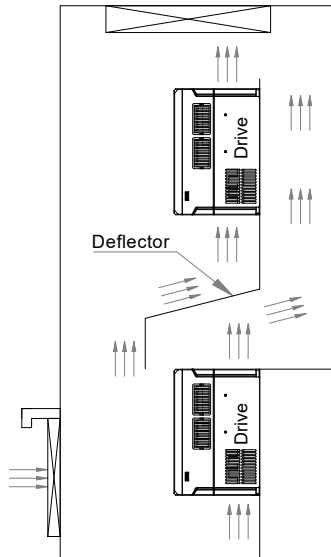

Figure 2-2 Installation Diagram of Multiple Drives

Table 2-1 Installation Space Requirements

Drive model	Installation space (mm)	
	A	B
HAV-SP-4T0022P~HAV-SP-4T0550P HAV-SP-2T0022P~HAV-SP-2T0300P	≥50	≥100
HAV-SP-4T0750P~HAV-SP-4T1600P HAV-SP-2T0370P~HAV-SP-4T0450P	≥50	≥200

2.1.3 Mechanical installation methods and steps

According to different power levels, HAV-SP series has two structures namely plastic and sheet metal. According to different installation applications, there are two installation methods: Wall-mounted and embedded.

1. Wall mounting of plastic structure

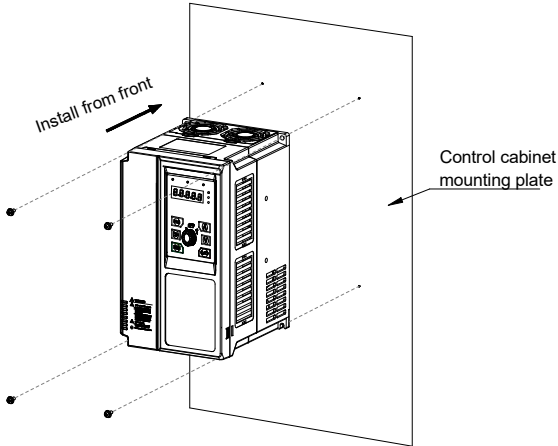

Figure 2-3 Wall-mounted Installation Diagram of Plastic Structure

2. Embedded installation of plastic structure

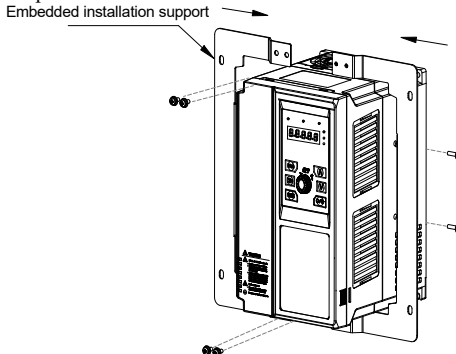

Figure 2-4 Embedded Support Installation Diagram of Plastic Structure

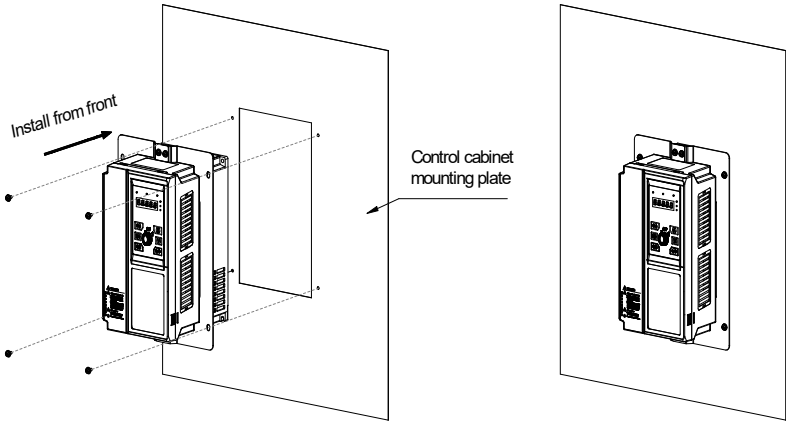

Figure 2-5 Embedded Installation Diagram of Plastic Structure

3. Wall mounting of sheet metal structure

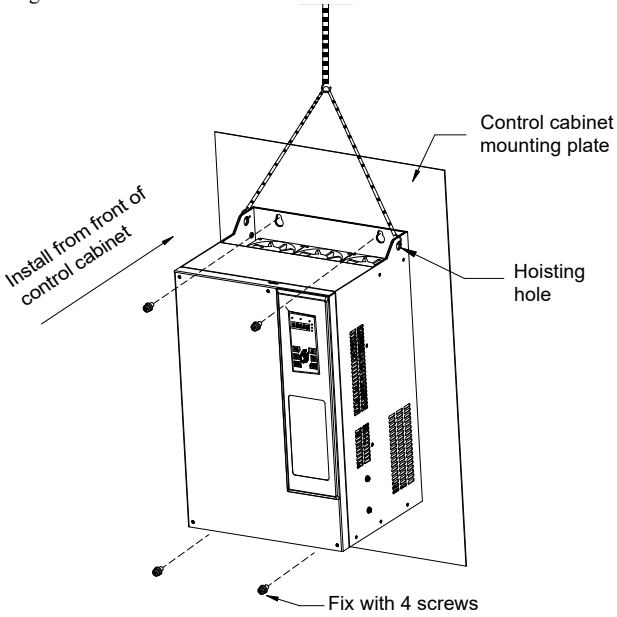

Figure 2-6 Wall-mounted Installation Diagram of Sheet Metal Structure

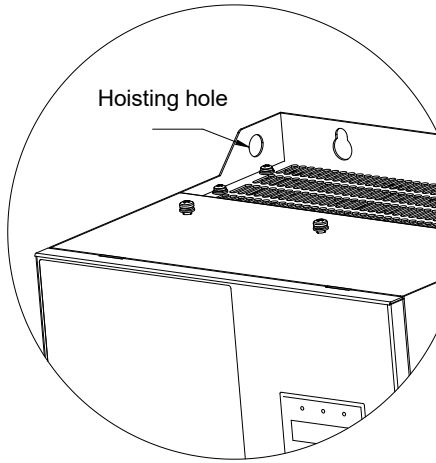

Figure 2-7 Hoisting Diagram of Sheet Metal Structure

4. Embedded installation of sheet metal structure

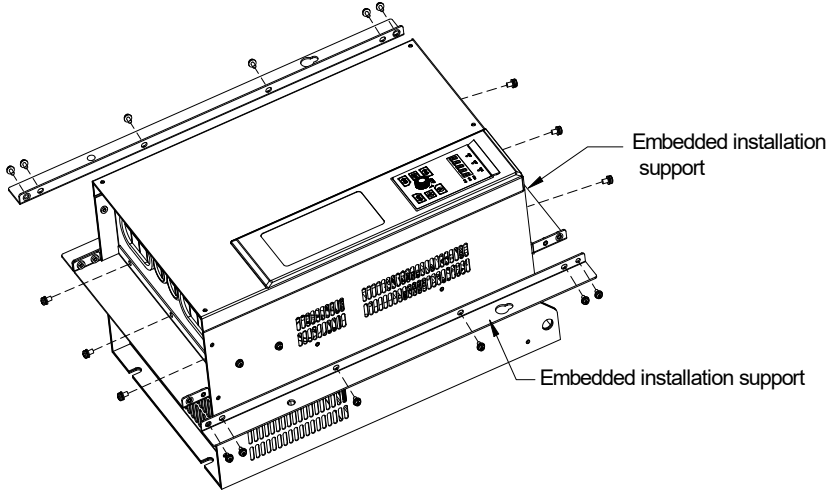

Figure 2-8 External Support Diagram of Sheet Metal Structure

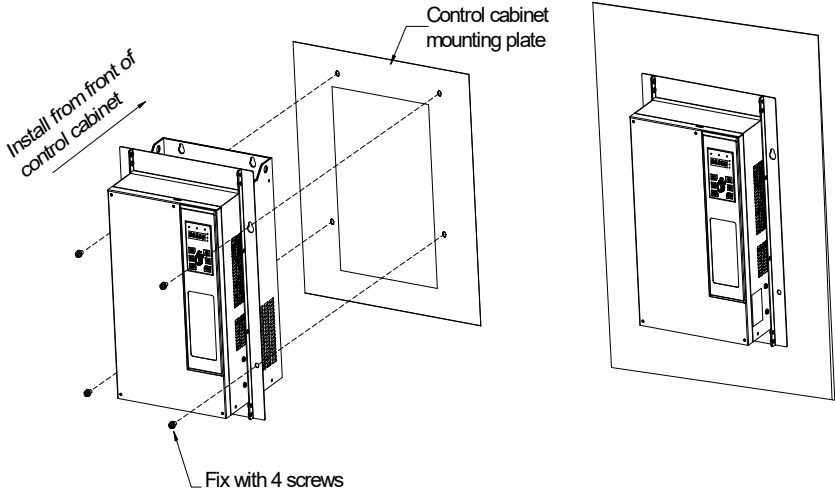

Figure 2-9 Embedded Installation Diagram of Sheet Metal Structure

Table 2-2 Matching Table of Embedded Installation Support

Model of Embedded Installation Support	Adaptable models
HAV-XS-4T0040QRZJ	HAV-SP-4T0022P~HAV-SP-4T0075P HAV-SP-2T0022P~HAV-SP-2T0040P
HAV-XS-4T0075QRZJ	HAV-SP-4T0110P~HAV-SP-4T0150P HAV-SP-2T0055P~HAV-SP-2T0075P
HAV-XS-4T0150QRZJ	HAV-SP-4T0185P~HAV-SP-4T0220P HAV-SP-2T0110P
HAV-XS-4T0220QRZJ	HAV-SP-4T0300P~HAV-SP-4T0370P HAV-SP-2T0015P~HAV-SP-2T0185P
HAV-XS-4T0370QRZJ	HAV-SP-4T0450P~HAV-SP-4T0550P HAV-SP-2T0220P~HAV-SP-2T0300P
HAV-XS-4T0750QRZJ	HAV-SP-4T0750P~HAV-SP-4T1100 HAV-SP-2T0370P~HAV-SP-2T0450P
HAV-XS-4T1320QRZJ	HAV-SP-4T1320P~HAV-SP-4T1600P

2.2. Removal and installation of drive panel

2.2.1 Removal and installation of drive cover plate with plastic case

◆ Remove cover plate

Use tools to jack out the hooks on the left and right sides of the cover plate in direction 1 as shown in Figure 2-10, and then lift the cover plate in direction 2.

◆ Install cover plate

Align the groove above the cover plate with the clip of the main body as shown in Figure 2-11,

and press down the cover plate in direction 1 until a “click” sound is heard.

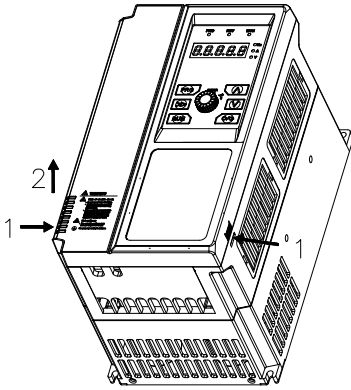

Figure 2-10 Removal of Cover Plate

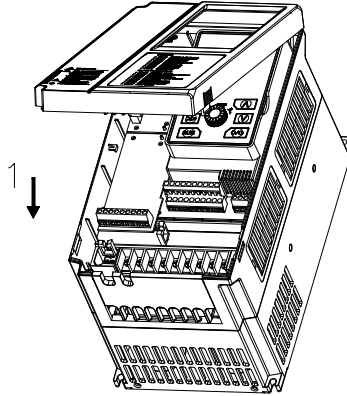

Figure 2-11 Installation of Cover Plate

2.2.2 Removal and installation of sheet metal box cover plate

◆ Remove cover plate

Remove the mounting screws at cover plate 1 in Figure 2-12, and then lift it up in direction 2.

◆ Install cover plate

Insert the clip of the cover plate into the groove of the main body as shown in Figure 2-13, install the cover plate in direction 1, and then fasten the screws at cover plate 2.

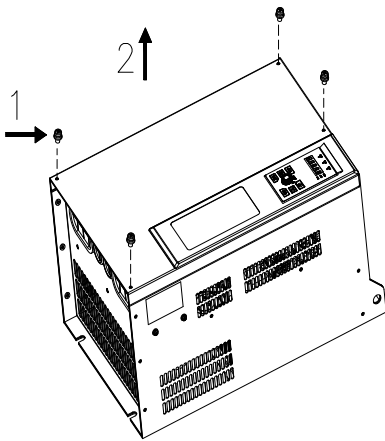

Figure 2-12 Removal of Cover Plate

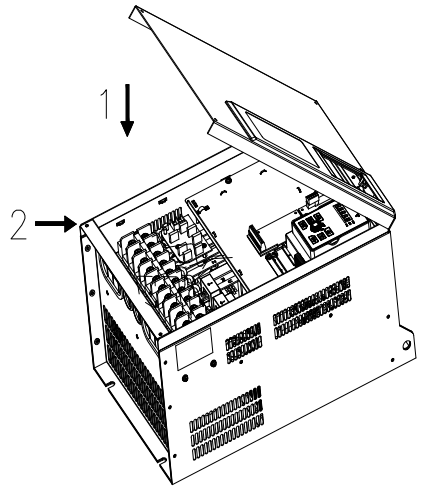

Figure 2-13 Installation of Cover Plate

2.2.3 Removal and installation of keypad

◆ Removal and installation of cover plate

- ◆ Remove the keypad
- ◆ Please refer to 2-10 to 2-13 to remove cover plates

Press groove 1 on both sides of the keypad with your fingers as shown in Figure 2-14, and then take out the keypad body in direction 2.

- ◆ Install the keypad

Insert the network cable into the network port in the control box as shown in Figure 2-15, and insert the other end onto the keypad, and then press down the keypad in the arrow direction until a “click” sound is heard. Never install the keypad from other directions, otherwise it may cause poor contact of the keypad.

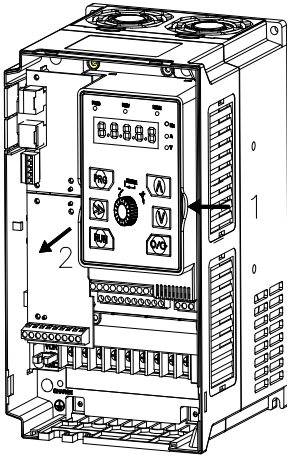

Figure 2-14 Removal of Keypad

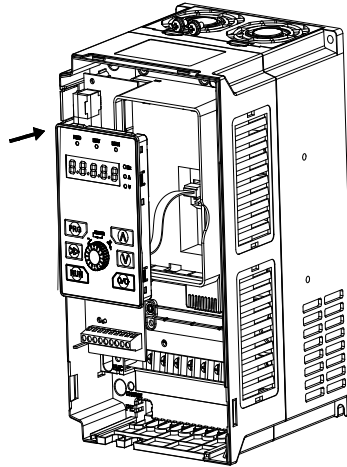

Figure 2-15 Installation of Keypad

2.3 Wiring of main circuit terminals

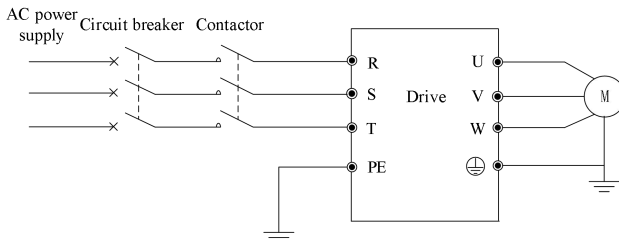

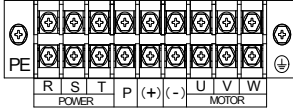

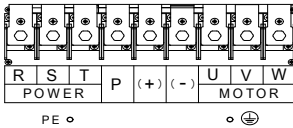



Figure 2-16 Basic Wiring of Main Circuit

2.3.1 Wiring of main circuit terminals

(1)The main circuit input and output terminals are shown in Table 2-3.

Applicable models	Main circuit terminals	Terminal name	Function description
HAV-SP-4T0022P HAV-SP-4T0030P HAV-SP-4T0040P HAV-SP-4T0055P HAV-SP-4T0075P HAV-SP-4T0110P HAV-SP-4T0150P HAV-SP-4T0185P HAV-SP-4T0220P HAV-SP-2T0022P HAV-SP-2T0030P HAV-SP-2T0040P HAV-SP-2T0055P HAV-SP-2T0075P HAV-SP-2T0110P		R, S, T U, V, W (+), BR (+), (-) PE	Three-phase AC 380V input terminal Three-phase AC output terminal Braking resistor wiring terminal Motor ground terminal DC positive and negative bus output terminals, and Protective ground terminal
HAV-SP-4T0300P HAV-SP-4T0370P HAV-SP-2T0150P HAV-SP-2T0185P		R, S, T U, V, W (+), BR (+), (-) PE	Three-phase AC 380V input terminal Three-phase AC output terminal Braking resistor wiring terminal DC positive and negative bus output terminals, and Motor ground terminal Protective ground terminal
HAV-SP-4T0450P HAV-SP-4T0550P HAV-SP-2T0220P HAV-SP-2T0300P		R, S, T U, V, W P, (+) (+), (-)	Three-phase AC 380V input terminal Three-phase AC output terminal Reserved terminal of external DC reactor DC positive and negative bus output terminals, and external brake unit terminals

Applicable models	Main circuit terminals	Terminal name	Function description
			Motor ground terminal
		PE	Protective ground terminal
HAV-SP-4T0750P HAV-SP-2T0370P		R, S, T	Three-phase AC 380V input terminal
		U, V, W	Three-phase AC output terminal
		P, (+)	Reserved terminal of external DC reactor
		(+), (-)	DC positive and negative bus output terminals, and external brake unit terminals
			Motor ground terminal
		PE	Protective ground terminal
HAV-SP-4T0900P HAV-SP-4T1100P HAV-SP-4T1320P HAV-SP-4T1600P HAV-SP-2T0450P		R, S, T	Three-phase AC 380V input terminal
		U, V, W	Three-phase AC output terminal
		P, (+)	Reserved terminal of external DC reactor
		(+), (-)	DC positive and negative bus output terminals, and
			Motor ground terminal
		PE	Protective ground terminal

(2) The selection of main circuit cable diameters, inlet protection circuit breaker QF or fuse in Table 2-4 is as follows:

Model	Circuit breaker (A)	Recommended contactor (A)	Recommended input and output power wires (mm ²)	Control wire (mm ²)
HAV-SP-4T0022P	16	10	2.5	1.0
HAV-SP-4T0030P	20	16	2.5	1.0
HAV-SP-4T0040P	20	16	2.5	1.0
HAV-SP-4T0055P	25	25	4	1.0
HAV-SP-4T0075P	40	32	4	1.0
HAV-SP-4T0110P	63	38	6	1.0
HAV-SP-4T0150P	63	40	6	1.0
HAV-SP-4T0185P	100	50	10	1.0
HAV-SP-4T0220P	100	65	10	1.0
HAV-SP-4T0300P	125	80	16	1.0
HAV-SP-4T0370P	160	95	25	1.0
HAV-SP-4T0450P	200	115	35	1.0
HAV-SP-4T0550P	200	170	35	1.0
HAV-SP-4T0750P	250	205	70	1.0
HAV-SP-4T0900P	315	245	70	1.0
HAV-SP-4T1100P	400	300	95	1.0
HAV-SP-4T1320P	400	300	150	1.0
HAV-SP-4T1600P	630	410	185	1.0

2.4 Control circuit configuration and wiring

2.4.1 Control circuit terminal arrangement is as follows

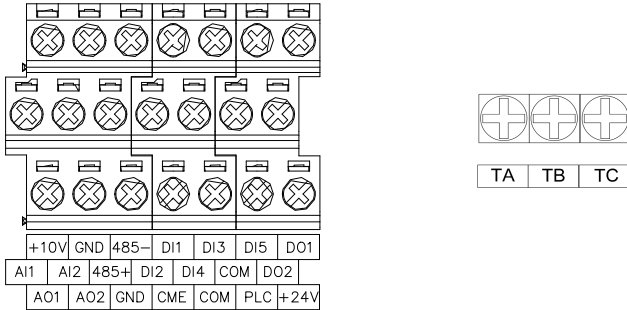

Note: Arrangement Sequence of control plate terminals of HAV-SP-4T0075P and below (HAV-SP-2T0040P and below)

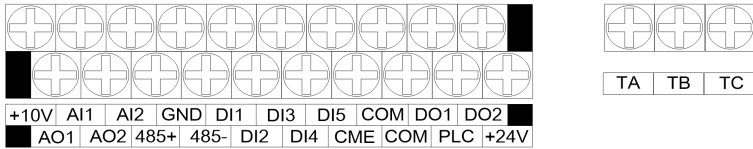

Note: Arrangement Sequence of control plate terminals of HAV-SP-4T0110P and above (HAV-SP-2T0055P and above)

Figure 2-17 Arrangement Sequence of Control Plate Terminals

2.4.2 CN2 terminal function description is shown in Table 2-5.

Table 2-5 Control Terminal Function Table

Category	Terminal Label	Name	Terminal function description	Specification
Communication	485+	RS485 communication interface	RS485 differential signal positive	For standard RS485 communication interface, please use twisted pair or shielded wire.
	485-		RS485 differential signal negative terminal	
Multifunctional output terminal	DO1 DO2	Open collector output terminal	It can be programmed and defined as switch output terminal with multiple functions, see terminal function parameters F6.11 and F6.12 for details, output terminal function introduction (common port: COM)	Optocoupler isolated output Working voltage range: 9-30V Maximum output current: 50mA
Relay output terminal	TA TB TC	Programmable relay Terminal output	No-action: TA-TB is normally off; TA-TC is normally on. Action: TA-TB is normally on; TA-TC is normally off.	Contact rating NO: 5A 250VAC NC: 3A 250VAC
	RA RB RC	Programmable relay Terminal output	No-action: RA-RB normally off; RA-RC normally on; Action: RA-RB normally on; RA-RC normally off	Contact rating NO: 5A 250VAC NC: 3A 250VAC (Note: Expansion card function)
Analog Input	AI1	Analog input AI1	Receive analog current and voltage input (reference ground: GND)	Input voltage range: 0~10V (input impedance: 100K Ω)
	AI2	Analog input AI2	Receive analog current and voltage input (reference ground: GND)	Resolution: 1/1000 Input current range: 0~20mA (Input impedance: 500 Ω) Resolution: 1/1000
Analog output	AO1	Analog output	Provide analog voltage output, which can correspond to 12 physical quantities, default output frequency when leaving the factory (see F5.25 for details)	Voltage output range: 0~10V Current output range: 0~20mA
	AO2	Analog output	Provide analog voltage output, which can correspond to 12 physical quantities, default output frequency when leaving	Voltage output range: 0~10V Current output range: 0~20mA
Multifunctional input terminal	DI1	Multifunctional	It can be programmed and defined as switch input terminal with multiple functions, see Chapter VI terminal function parameters (switch input and output) for input terminal function introduction. (Common port: COM) (See F6.00-6.04 for details)	
	DI2	Multifunctional		
	DI3	Multifunctional		
	DI4	Multifunctional		
	DI5	Multifunctional input terminal 5		
	DI6	Multifunctional	It can be programmed and defined as switch input terminal with multiple	Note: Expansion card function
	DI7	Multifunctional		

Category	Terminal Label	Name	Terminal function description	Specification
	DI8	Multifunctional input terminal 8		
Power supply	10V	+10V power	Provides +10V power supply for	Maximum output
	GND	+10V power	Reference ground of analog signal and	COM and GND are internally isolated from each other
	COM	+24V power supply common	Digital signal input and output common port	
	+24V	+24V power	Digital signal power supply	Maximum output
	PLC	Multifunctional	Common port of DI1-DI5	Shot-circuited to 24V
	CME	Digital output	Multifunctional output terminal	Short-circuited to COM

2.4.3 Wiring of analog input and output terminals

AI1 and AI2 terminals receive analog signal input and select input voltage (0~10V) or input current (0~20mA) through jumpers J1 and J2. Terminal wiring mode is shown in Figure 2-18(a):

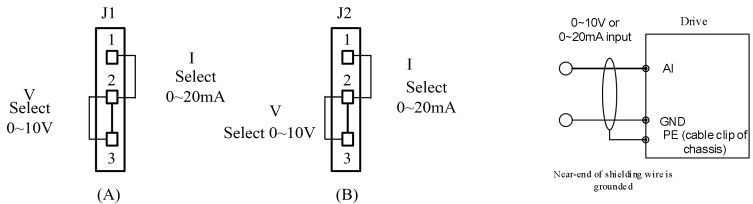

Figure 2-18(a) Analog Input Terminal Wiring

The analog outputs AO1 and AO2 can output both voltage and current, which can be selected by jumpers J3 and J4. AO1 and AO2 are default to 0~10v voltage output, and the corresponding output physical quantities are set by parameters F5.25 and F5.26.

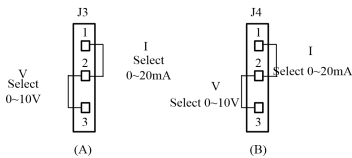

Figure 2-18(b) Analog Output Terminal Wiring

2.4.4 Wiring mode of drive control circuit

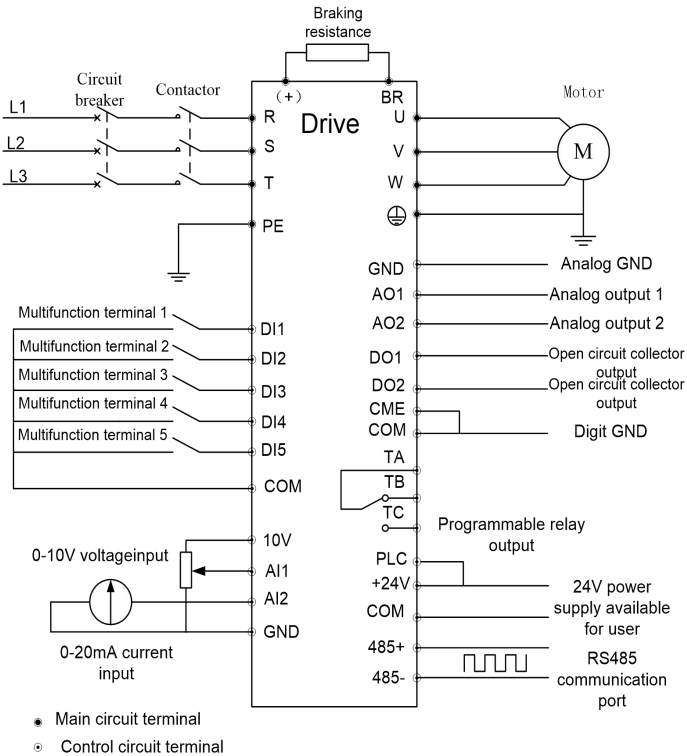

Figure 2-19 Basic Operation Wiring Diagram

Applicable models: HAV-SP-4T0370P and below

HAV-SP-2T0185P and below

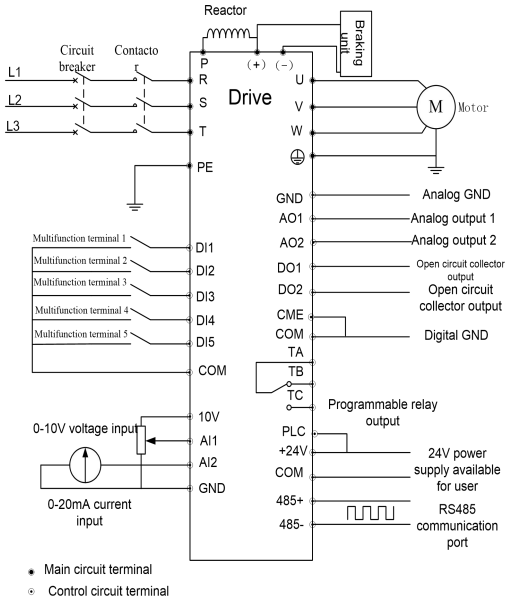

Figure 2-20 Basic Operation Wiring Diagram

Applicable models: HAV-SP-4T0450P and above

HAV-SP-2T0220P and above

2.4.5 Wiring of signal input terminal

NPN and PNP mode switching terminals are shown in Figure 2-21 to Figure 2-24.

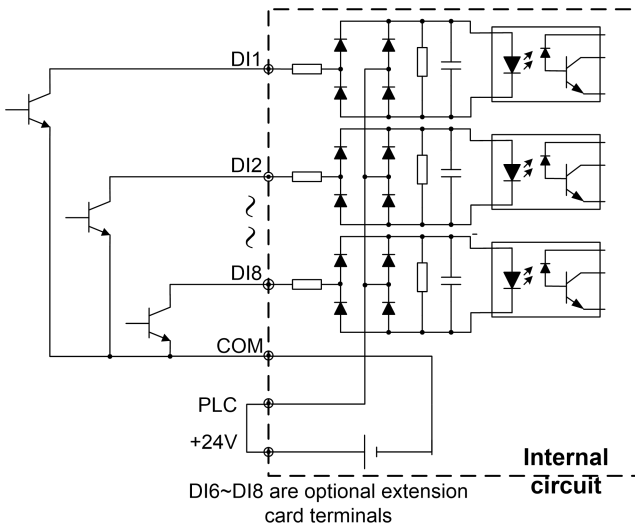

Figure 2-21 NPN Diagram of Internal Power Supply (OC)

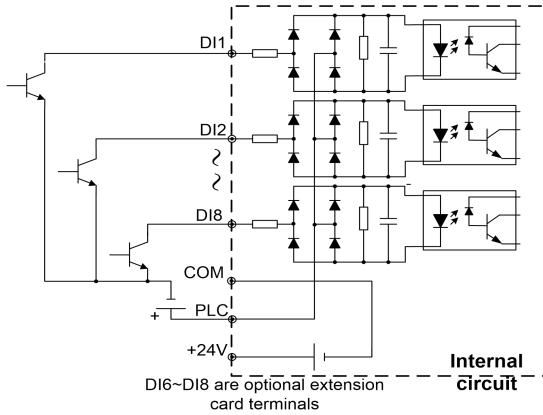

Figure 2-22 NPN Diagram of External Power Supply (OC)

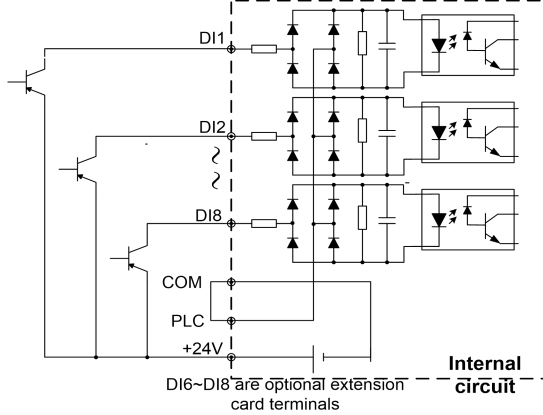

Figure 2-23 PNP Diagram of Internal Power Supply (OE)

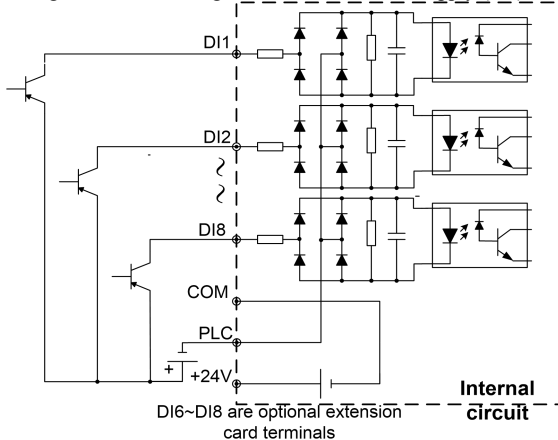













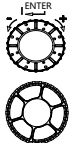





Figure 2-24 PNP Diagram of External Power Supply (OE)

Chapter III Operation Instructions of Drive

3.1 Key function description

The key functions of HAV-SP-LKD and HAV-SP-LCD are defined in Table 3-1.

Table 3-1 Keypad Function Table

Key	Name	Label in the manual	Function description
	Program/Exit key		Enter or exit programming state
	Run key		In the keypad mode, press this key to run the drive.
	Stop key		When the drive is in the normal running state, if the drive's running instruction channel is set to the keypad stop effective mode, press this key and the drive will stop according to the set mode. When the drive is in the fault state, press this key to reset the drive and return to the normal stop state.
	Increment key		Increase data or function code
	Decrement key		Decrease data or function code
	Shift key		In the edit state, you can select the modification bit of the set data
	Rotary encoder		When pressed down, it is the  key, you can enter the drop-down menu or confirm data. When the input frequency channel is set to keypad, the rotary encoder can modify the set frequency of the drive.
	Enter key		Enter menu or data confirmation
	SHT		Shift between digits

3.2 Keypad operation methods

You can perform various operations on the drive by operating the keypad, as follows:

3.2.1 Shortcut monitoring parameter view

6 shortcut parameters are fixedly displayed in the shortcut monitoring interface, which can be switched by the Up or Down key. When the ENT key is pressed down in this interface, it will immediately return to the first shortcut parameter, and the 6 shortcut parameter sequence list is as follows.

Shortcut parameter 1	Determined by function code FC.17
Shortcut parameter 2	Output current
Shortcut parameter 3	Bus voltage
Shortcut parameter 4	Set frequency
Shortcut parameter 5	AI1
Shortcut parameter 6	Terminal state 1

The above is the shortcut display in the general mode, which will vary with different industry characteristics in other industry selections.

3.2.2 Settings of function code parameters

The function parameter system of this drive includes function code F0~FF group, monitoring parameter U0 group, and fault record parameter U1 group. Each function group includes several function codes. The function code is identified by (function code group number + function code number). For example, "F5.08" indicates the 8th function code of the 5th function group.

Function code setting example:

Example 1: Change the forward jog frequency setting from 5Hz to 10Hz (F2.20 changed from 5.00Hz to 10.00Hz)

1) Press the **PRG** key to enter the programming state, the digital tube displays function parameter "-F0-", and press the **▲** key to make the LED digital tube display "-F2-".

2) Press **ENT**, you can see the digital tube displays function parameter "F2.00".

3) Press the **▲** key to make the digital tube display function parameter "F2.20".

4) Press the **ENT** key, you will see the data (5.00) corresponding to F2.20, meanwhile, the LED (Hz) corresponding to its unit frequency lights up.

5) Press the **▶▶** key, if flashes, shift to the highest bit "5", and press the **▲** key five times, to change to **10.00**.

6) Press the **ENT** key, if the parameter does not flash, it indicates the modification is successful.

7) Press the **PRG** key, to exit the programming state.

Note: In P.off state, it is forbidden to modify the function code parameter.

3.2.3 Jog function operation

Use the keypad to perform the jog operation of the drive:



1) Press the **PRG** key three times to enter the jog operation state, and the digital tube displays function parameter "JOG-".



2) Press and hold the Up key to forward and jog.

3) Press and hold the Down key to reverse and jog.

3.2.4 Parameter upload and download operations

The external keypad has the functionality of uploading and downloading the function code.

1) On the external keypad, press the  key + the  key, to execute the function code uploading function. The external keypad reads all the function code values from the control board, and then writes into the keypad memory chip.

2) On the external keypad, press the  key + the  key, to execute the function code downloading function. The external keypad reads all the function code values from the memory chip, and then writes into the drive control board chip. However, when downloading, the keypad will automatically distinguish the software version, drive voltage level, and drive power level. The specific conditions are as follows:

a. If the downloaded function code is inconsistent with the drive software version of the parameter to be downloaded, it will not be downloaded and an E028 fault will be reported.

b. If the downloaded function code is inconsistent with the drive voltage level of the parameter to be downloaded (e.g. the downloaded function code is of 2S model, but the drive is of 4T model), it will not be downloaded and an E028 fault will be reported.

c. If the downloaded drive model parameter is inconsistent with the drive model of the drive whose parameter are being downloaded, the download will not be performed and an E028 fault will be reported.

d. If the software of drive is consistent with the software version, voltage level, and machine model of the parameters to be downloaded, but the power level is inconsistent, the “F3 group: Motor related parameters” will not be downloaded, and other parameters will be downloaded normally.

e. If the downloaded function code is consistent with the drive’s software version, voltage level, machine model, and power level of the parameters to be downloaded, all parameters will be downloaded

Chapter IV Function Parameter Table

4.1 Function parameter table

Description of symbols in the table:

- × - Indicates this parameter cannot be changed during the operation.
- - Indicates this parameter can be changed during the operation.
- - Indicates the actual test parameter, which cannot be changed.
- * - Indicates this parameter is the reserved parameter of the manufacturer, which is prohibited to be changed.

Parameter Code	Parameter name	Parameter detailed description	Minimum Unit	Factory value	Change								
F0 group: System management parameters													
F0.00	Parameter operation protection	0: Password operation. You can view the function code value without entering a password, but you cannot change it. You need to enter the correct password in F0.05 before changing the function code. 1: Password operation. You cannot view the function code value when no password is entered, and the function code will display "----". You need to enter the correct password in F0.05 before viewing and changing the function code. Note: This function will take effect only after setting the function code operation password in F0.05.	1	0	○								
F0.01	Reserved	-	-	-	*								
F0.02	Drive operation deadline	Set range: 0~Maximum timing 65535h 0 indicates unlimited.	1h	0h	○								
F0.03	Parameter initialization	0: No operation 1: Restore the factory settings (the drive model, running time, and fault records will not be restored) 2: Clear the fault memory information (clear fault memory parameters of U1 group)	1	0	×								
F0.04	Industry code	0: Universal drive 1: Special drive for water supply Note: Changing the industry code will restore other function codes to their factory settings. The factory value of part of function codes of the special drive for water supply is restored according to the following list: <table border="1" style="margin-left: auto; margin-right: auto; border-collapse: collapse;"> <thead> <tr> <th style="text-align: center;">Function code</th> <th style="text-align: center;">Factory value</th> </tr> </thead> <tbody> <tr> <td style="text-align: center;">F1.01</td> <td style="text-align: center;">1</td> </tr> <tr> <td style="text-align: center;">F1.02</td> <td style="text-align: center;">8</td> </tr> <tr> <td style="text-align: center;">F8.14</td> <td style="text-align: center;">4ms</td> </tr> </tbody> </table>	Function code	Factory value	F1.01	1	F1.02	8	F8.14	4ms	1	0	×
Function code	Factory value												
F1.01	1												
F1.02	8												
F8.14	4ms												

Parameter Code	Parameter name	Parameter detailed description	Minimum Unit	Factory value	Change				
		<table border="1"> <tr> <td>F8.15</td> <td>5.0%</td> </tr> <tr> <td>FC.17</td> <td>14</td> </tr> </table>	F8.15	5.0%	FC.17	14			
F8.15	5.0%								
FC.17	14								
F0.05	Function code operation password	<p>Setting range: 0~65535 0 indicates no password, set any non-zero number, the password protection function will take effect immediately, please keep the set password in mind. After setting the password, if you want to clear the password, you must enter the correct password first, and then set the password value to 0. After setting the password, if you want to change the password, you must clear the password before you can set a new password. Note: The password protection authority is set in F0.00, which is used to prohibit unauthorized personnel from viewing and changing the function code parameters.</p>	1	0	○				
F1 group :Basic operating parameters									
F1.00	Control method	<p>0: Reserved 1: V/F control: Sound versatility, and stable operation, can effectively improve low-frequency torque and suppress current oscillation, with slip compensation and automatic voltage adjustment functions, further improving control accuracy.</p>	1	1	×				
F1.01	Run command channel selection	<p>0: Keypad run command channel: By the RUN key, and the STOP key, you can control the drive to run and stop, press and hold the ▲ key and the ▼ key in the “JOG-” interface, you can perform forward jog and reverse jog. 1: Terminal run command channel: Control the running and stopping of the drive through the multifunctional input terminal forward, reverse, forward jog, reverse jog, etc. (The corresponding multifunctional input terminal’s function must be defined by the F6 and Fd parameter groups). 2: Serial port run command channel: Control the running and stopping of the drive through communication.</p>	1	0	○				

Parameter Code	Parameter name	Parameter detailed description	Minimum Unit	Factory value	Change
F1.02	Main frequency X input channel selection	<p>0: Keypad digital potentiometer input. The frequency is set by adjusting the digital potentiometer on the panel.</p> <p>1: Digital input 1, setting frequency by modifying function code F1.05 (corresponding to auxiliary frequency Y) or F1.07 (corresponding to main frequency X).</p> <p>2: Digital input 2. The frequency is adjusted by setting the UP/DN function through the multifunctional input terminal.</p> <p>3: Digital input 3, communication input. The frequency is set by the serial port frequency set command.</p>	1	0	○
F1.03	Auxiliary frequency Y input channel selection	<p>4: AI1 input, frequency setting is determined by AI1 terminal analog voltage/current, input range: DC 0~10V or DC 0~20mA (J1 jumper selection), and the corresponding frequency curve is set in F5.00~F5.05 function code.</p> <p>5: AI2 input, frequency setting is determined by AI2 terminal analog voltage/current, input range: DC 0~10V or DC 0~20mA (AI2 jumper selection), and the corresponding frequency curve is set in F5.00~F5.05 function code.</p> <p>6: Terminal pulse input, the frequency setting is determined by the terminal pulse frequency (input by DI5, and the function code F6.19 needs to be set to “high-frequency pulse input” function before use), the input pulse signal frequency range is 0~50.0kHz, and the corresponding frequency curve is set in F5.19~F5.23 function code.</p> <p>7: Multistage instruction input, the drive runs in multistage instruction mode, selects multistage speed operation or simple PLC operation through function code F9.00.</p> <p>When multistage speed operation is selected, set the multistage speed terminal combination through group F6 and Fd to select the current running stage, and determine the current running frequency and acceleration/deceleration time through group F9 function code.</p> <p>When simple PLC operation is selected, determine the PLC operation mode, the number of operation stages, the phase operation frequency, the phase operation direction, and the phase operation time</p>	1	1	○

Parameter Code	Parameter name	Parameter detailed description	Minimum Unit	Factory value	Change
		through group F9 function code. 8: PID input, the drive operation mode is process PID control, and the operation frequency is the frequency value after PID action. In this case, you need to set PID related functions through group F8. 9-15: Reserved			
F1.04	Frequency source combination mode	0: X, the current frequency is set to the main frequency X. 1: Y, the current frequency is set to the auxiliary frequency Y. 2: X+Y, the current frequency is set to the main frequency X + the auxiliary frequency Y. 3: X-Y, the current frequency is set to the main frequency X - the auxiliary frequency Y. 4: Max (X,Y). The larger of the main frequency X and the auxiliary frequency Y is the set frequency. 5: Min (X,Y). The smaller of the main frequency X and the auxiliary frequency Y is the set frequency. Note: If the X and Y directions are not the same, the frequency direction after the combination of 2 and 3 is based on the main frequency X, while 4 and 5 is based on the selected frequency direction. Besides the calculation during combination is based on the absolute value of the main and auxiliary frequencies, if the calculated value is less than 0, it will run at zero frequency. The combination mode can be switched through the multifunctional input terminal (group F6).	1	0	○
F1.05	Digital setting of auxiliary frequency Y	Set range: Lower limit frequency~upper limit frequency When the auxiliary frequency Y input channel is selected to “digital setting 1”, this function code value is the frequency set value of the auxiliary frequency Y.	0.01Hz	50.00Hz	○
F1.06	Maximum output frequency	Set range: Upper limit frequency~650.00Hz	0.01Hz	50.00Hz	×

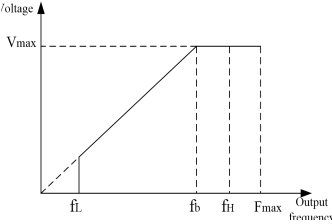
Parameter Code	Parameter name	Parameter detailed description	Minimum Unit	Factory value	Change
		 <p>1. The maximum output frequency is the highest frequency allowed by the drive, such as f_{max} shown in the figure.</p> <p>2. The rated frequency of F3.04 is the corresponding minimum frequency when the drive outputs the highest voltage, such as f_b shown in the figure.</p> <p>3. The maximum output voltage of F3.05 is the corresponding output voltage when the drive outputs the rated frequency, such as V_{max} shown in the figure.</p> <p>Note: Be sure to set f_{max}, f_b, and V_{max} according to the motor parameters, otherwise the equipment may be damaged.</p>			
F1.07	Main frequency X digital setting	Set range: Lower limit frequency~upper limit frequency When the main frequency X input channel is selected to “digital setting 1”, this function code value is the frequency set value of the main frequency X.	0.01Hz	50.00Hz	○
F1.08	Reserved	-	-	-	*
F1.09	Upper limit frequency	Set range: Lower limit frequency~maximum output frequency The upper limit frequency is the upper limit value of the output frequency of the drive. The value shall be less than or equal to the maximum output frequency. When the set frequency is higher than the upper limit frequency, it runs at the upper limit frequency.	0.01Hz	50.00Hz	○
F1.10	Lower limit frequency	Set range: 0.00~upper limit frequency The lower limit frequency is the lower limit value of the drive output frequency. When the set frequency is lower than the lower limit frequency, it runs at the lower limit frequency. Note: Maximum output frequency \geq upper limit frequency \geq lower limit frequency	0.01Hz	0.00Hz	○

Parameter Code	Parameter name	Parameter detailed description	Minimum Unit	Factory value	Change
F1.11	Acceleration time 1	<p>Set range: 0.01 ~ 600.00</p> <p>1. The acceleration time refers to the time required for the drive to accelerate from zero frequency to the rated frequency of the motor, as shown in t1 in the figure.</p> <p>2. The deceleration time refers to the time required for the drive to decelerate from the rated frequency to zero frequency of the motor, as shown in t2 in the following figure.</p>			○
F1.12	Deceleration time 1	<p>3. There are four groups of acceleration and deceleration time parameters for this series of drives. Other acceleration and deceleration time (2, 3, 4) are defined in parameters F2.14 ~ F2.19. The factory default acceleration/deceleration time is acceleration/deceleration time 1. To select other acceleration and deceleration time groups, you must select them by terminal (see group F6 parameters). The acceleration and deceleration times during the motor parameter self-tuning operation are set in F3.13 separately. The acceleration and deceleration times during jog operation are set in F2.22 and F2.23 separately.</p> <p>4. The acceleration time is only valid for normal acceleration process, excluding start DC braking time and start frequency hold time. The deceleration time is only valid for normal deceleration process, excluding stop DC braking time.</p> <p>Note: The default unit is s. For the selection of acceleration/deceleration time unit, see FC.07.</p>	0.01	Model determination	○
F1.13	Acceleration/deceleration filtering time	<p>Set range: 0 ~ 1000ms (0 indicates on filter)</p> <p>Acceleration/deceleration filter time constant. The longer the filter time is, the longer the actual acceleration/deceleration time that set.</p>	1ms	0ms	○
F1.14	Reserved	-	-	-	*
F1.15	Reserved	-	-	-	*
F1.16	Reserved	-	-	-	*

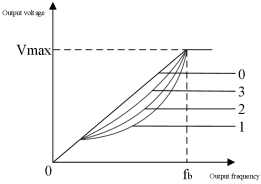
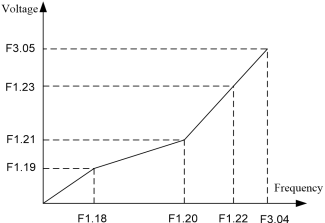
Parameter Code	Parameter name	Parameter detailed description	Minimum Unit	Factory value	Change
F1.17	V/F curve setting	<p>The V/F setting mode is defined in this function code, to meet the needs of different load characteristics. According to the definition, you can select 4 fixed curves and 1 custom curve.</p> <p>0: Straight line V/F, as shown in curve 0 in the figure.</p> <p>1: User-defined V/F curve, see F1.18~F1.23 function code setting for details.</p> <p>2: Reduced torque characteristic curve 1 (2.0 power), as shown in curve 1 in the figure.</p> <p>3: Reduced torque characteristic curve 2 (1.7 power), as shown in curve 2 in the figure.</p> <p>4: Reduced torque characteristic curve 3 (1.2 power), as shown in curve 3 in the figure.</p>  <p>Note: Curves 1, 2, and 3 are suitable for variable torque loads of fans and pumps. Users can adjust according to the load characteristics to achieve the best energy saving effect.</p>	1	0	×
F1.18	V/F frequency value F1	F1.18 set range: 0.00~F1.20 F1.19 set range: 0~F1.21 F1.20 set range: F1.18~F1.22	0.01Hz	12.50Hz	×
F1.19	V/F voltage value V1	F1.21 set range: F1.19~F1.23 F1.22 set range: F1.20~F3.04 F1.23 set range: F1.21~100.0%	0.1%	25.0%	×
F1.20	V/F frequency value F2		0.01Hz	25.00Hz	×
F1.21	V/F voltage value V2		0.1%	50.0%	×
F1.22	V/F frequency value F3	When the F1.17V/F curve is set to 1, the user can customize the V/F curve through F1.18~F1.23, as shown in the figure. The V/F curve is defined by adding (V1, F1),	0.01Hz	37.50Hz	×

Parameter Code	Parameter name	Parameter detailed description	Minimum Unit	Factory value	Change												
F1.23	V/F voltage value V3	<p>(V2, F2), and (V3, F3) three-point line, to adapt to special load characteristics.</p> <p>2. This function parameter group is used to flexibly set the V/F curve required by the user. Note: $V1 < V2 < V3$, $F1 < F2 < F3$, setting the low-frequency voltage too high may cause the motor to overheat or even get burned, and the drive may also have overcurrent stall or overcurrent protection. It shall be set according to the load characteristics of the motor.</p>	0.1%	75.0%	×												
F1.24	Running direction setting	<p>0: Forward 1: Reverse The direction of the motor can be changed by changing this function code. Its function is equivalent to changing the direction of rotation of the motor by adjusting any two lines of the motor lines U, V, and W. Note: After the function code parameters are restored to the factory setting, the motor running direction will be restored to the factory value. Use with caution on the occasions that it is forbidden to change the motor steering after system debugging. Set range: 1~15kHz</p>	1	0	○												
F1.25	Carrier frequency setting	<table border="1" style="margin-left: auto; margin-right: auto;"> <thead> <tr> <th>Carrier frequency</th> <th>Motor noise</th> <th>Leakage current</th> <th>Interference</th> </tr> </thead> <tbody> <tr> <td>Decrease</td> <td style="text-align: center;">↑</td> <td style="text-align: center;">↓</td> <td style="text-align: center;">↓</td> </tr> <tr> <td>Increase</td> <td style="text-align: center;">↓</td> <td style="text-align: center;">↑</td> <td style="text-align: center;">↑</td> </tr> </tbody> </table> <p>1. Advantages of high carrier frequency: Ideal current waveform, less current harmonics, and low motor noise. 2. Disadvantages of high carrier frequency: The switching loss increases, the drive temperature rises and the output ability of the drive is affected. Under high carrier frequency, the drive needs to be derated; at the same time, the leakage current of the drive increases, and the external electromagnetic interference increases. 3. The use of low carrier frequency is contrary to the above situation. Too low carrier frequency will cause low frequency operation instability, torque decrease and even oscillation. 4. When the drive leaves the factory, the manufacturer has set the carrier frequency reasonably. Generally, users do not need</p>	Carrier frequency	Motor noise	Leakage current	Interference	Decrease	↑	↓	↓	Increase	↓	↑	↑	1kHz	Model determination	○
Carrier frequency	Motor noise	Leakage current	Interference														
Decrease	↑	↓	↓														
Increase	↓	↑	↑														

Parameter Code	Parameter name	Parameter detailed description	Minimum Unit	Factory value	Change
		to change this parameter.			
F1.26	Overmodulation factor	Setting range: 100~150% This function enables PWM to work when the modulation ratio is greater than 1, which can increase the output voltage of the drive. Thereby increasing the torque output and effectively improving the maximum load capacity of the motor but the harmonic components of the output voltage will increase and cause the temperature of the motor to rise.	1%	110%	×
F1.27	Automatic carrier frequency adjustment	0: disable 1: enable When the automatic adjustment of the carrier frequency is enabled, the drive will automatically adjust the carrier frequency according to the temperature.	1	0	○
F2 group: Start-stop control					
F2.00	Start operation mode	LED single digit: Start mode 0: Start from the start frequency: Start at the start frequency set by F2.01, and accelerate to the set frequency after running the hold time set by F2.02 at this frequency. 1: Brake first and then start from the start frequency: First start with the DC braking current set in F2.03 and the DC braking time	11	00	×

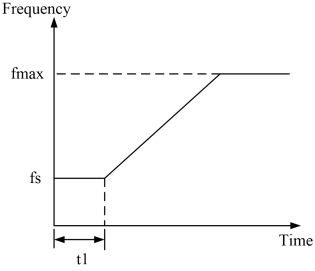
Parameter Code	Parameter name	Parameter detailed description	Minimum Unit	Factory value	Change
		<p>set in F2.04 for DC braking and then start from the start frequency.</p> <p>2: Speed tracking and restart: Track the current speed and direction of the motor, and perform smooth start without impact on the motor that is still rotating.</p> <p>LED tens digit: Speed tracking mode</p> <p>0: Track down from the frequency of shutdown, usually this method is used.</p> <p>1: Track down from the maximum frequency, suitable for power generation load.</p>			
F2.01	Start frequency	<p>F2.01 set range: 0.20~60.00Hz</p> <p>F2.02 set range: 0.0~10.0s</p> 	0.01Hz	0.50Hz	○
F2.02	Start frequency hold time	<p>1. The start frequency refers to the initial frequency of the drive at start. As shown in f_s in the figure, setting a proper start frequency can increase the torque at start.</p> <p>2. Within the hold time of the start frequency, as shown as t_1 in the figure, the output frequency of the drive is the start frequency, and then operate from the start frequency to the target frequency.</p> <p>3. The start frequency value is not limited by the lower frequency limit.</p>	0.1s	0.0s	○
F2.03	Start DC braking current	<p>F2.03 set range: 0.0~150.0% drive rated current</p> <p>F2.04 set range: 0.0~30.0S (0.0 indicates the DC braking is not active)</p>	0.1%	100.0%	○

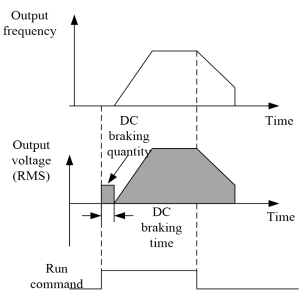
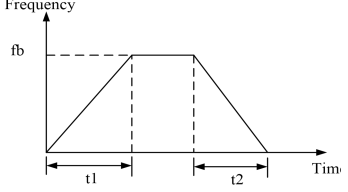
Parameter Code	Parameter name	Parameter detailed description	Minimum Unit	Factory value	Change
F2.04	Start DC braking time	 <p>The process of brake first and then restart from the start frequency, as shown in the figure: When the drive is put into operation, first perform the DC braking before starting according to the DC braking current and the DC braking time set by F2.03 and F2.04; then start from this frequency and operate the set time according to the regulations of F2.01 and F2.02; then enter the normal acceleration phase according to parameters such as the set acceleration and deceleration times, the acceleration and deceleration time methods, etc. and accelerate to the set frequency.</p>	0.1s	0.0s	○
F2.05	Acceleration/deceleration mode selection	<p>0: Linear acceleration/deceleration: The output frequency increases or decreases linearly</p>  <p>1: Reserved</p>	1	0	×
F2.06	Start protection selection (only valid for two-wire control)	<p>This function realizes whether the drive automatically starts running when the drive is powered on, the fault is cleared, or the command channel is switched to the terminal two-wire mode.</p> <p>0: If the run command is valid, the drive does start, and the drive is in the running protection state. The drive will not run until the run command terminal is canceled and then the terminal is enabled.</p> <p>1: If the run command is valid, the drive speed tracking starts.</p>	1	0	×

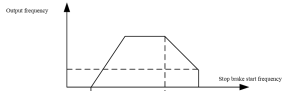
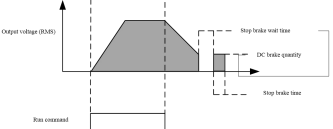
Parameter Code	Parameter name	Parameter detailed description	Minimum Unit	Factory value	Change
		Note: For safety, be cautious when setting to 1.			
F2.07	Start protection wait time	Set range: 0.0~10.0s	0.1s	0.0s	○
F2.08	Stop mode	0: Deceleration stop: After receiving the stop command, the drive will gradually reduce the output frequency according to the deceleration time, and stop when the frequency reaches to zero. 1: Free running stop: After receiving the stop command, the drive immediately stops the output, and the load stops freely according to the mechanical inertia. 2: Deceleration stop + DC braking: After receiving the stop command, the drive reduces the output frequency according to the deceleration time, and starts the DC braking when reaching the stop braking start frequency.	1	0	×
F2.09	DC braking start frequency at stop	F2.09 set range: 0.00~60.00Hz F2.10 set range: 0.00~10.00s F2.11 set range: 0.0~150.0% drive rated current F2.12 set range: 0.0~60.0S (0.0 indicates the DC braking does not act) F2.13 set range: 0~1	0.01Hz	0.00Hz	○
F2.10	DC braking wait time at stop		0.01s	0.10s	○
F2.11	DC braking current at stop		0.1%	100.0%	○
F2.12	DC braking time at stop	1. DC braking start frequency at stop: Means that the drive starts DC braking when reaching this frequency during the deceleration stop. 2. DC braking wait time at stop: During decelerating and stopping, the time interval from the moment when the operation frequency reaches the start frequency of braking to the moment when the DC braking is applied. 3. DC braking current at stop: Refers to the DC braking amount that added. The larger the current, the stronger the DC	0.1s	0.0s	○

Parameter Code	Parameter name	Parameter detailed description	Minimum Unit	Factory value	Change
F2.13	Action selection within DC braking wait time at stop	braking effect. 4. DC braking time at stop: The duration of the DC braking amount. When the time is set to 0, the DC braking is disabled. 5. Action selection during stop DC braking wait time: Refers to the operation status of the drive during the braking wait time. When set to 0, it indicates no output, when set to 1, it indicates to run at the braking start frequency.	1	1	○
F2.14	Acceleration time 2	Set range: 0.01~600.00 For specific definition, see F1.11 and F1.12. Note: The default unit is s. For the selection of acceleration/deceleration time unit, see FC.07.	0.01	Model determination	○
F2.15	Deceleration time 2				○
F2.16	Acceleration time 3				○
F2.17	Deceleration time 3				○
F2.18	Acceleration time 4				○
F2.19	Deceleration time 4				○
F2.20	Jog run frequency	Set range: 0.10~F1.09 Define the frequency during jog operation.	0.01Hz	5.00Hz	○
F2.21	Jog interval time	Set range: 0.0~100.0s	0.1s	0.0s	○
F2.22	Jog acceleration time	Set range: 0.01~600.00s 1. The acceleration time refers to the time required for the drive to accelerate from zero frequency to the jog run frequency F2.20 of the motor.	0.01s	6.00s	○
F2.23	Jog deceleration time	2. The jog deceleration time refers to the time required for the drive to decelerate from the jog run frequency F2.20 to zero frequency of the motor.			○
F2.24	Jump frequency 1	F2.24 set range: 0.00~650.00Hz	0.01Hz	0.00Hz	×
F2.25	Hop frequency 1 range	F2.25 set range: 0.00~30.00Hz F2.26 set range: 0.00~650.00Hz F2.27 set range: 0.00~30.00Hz F2.28 set range: 0.00~650.00Hz	0.01Hz	0.00Hz	×
F2.26	Hop frequency 2	F2.29 set range: 0.00~30.00Hz	0.01Hz	0.00Hz	×

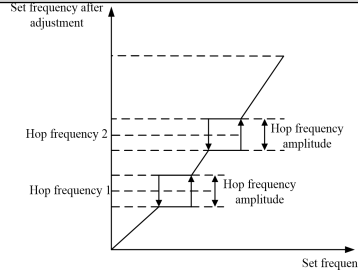
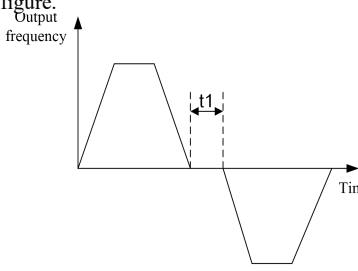
Parameter Code	Parameter name	Parameter detailed description	Minimum Unit	Factory value	Change
F2.27	Hop frequency 2 range		0.01Hz	0.00Hz	×
F2.28	Hop frequency 3		0.01Hz	0.00Hz	×
F2.29	Hop frequency 3 range		<p>1. Set the hopping frequency can make the drive avoid the mechanical resonance point of the load. When the hopping frequency is set to 0, this function is invalid. Once these hopping points are set, the drive will automatically avoid stable operation at these frequency points during operation.</p> <p>2. During the acceleration and deceleration, the output frequency of the drive can cross the hopping frequency zone normally.</p>	0.01Hz	0.00Hz
F2.30	Forward and reverse dead zone time	<p>Set range: 0.00~360.00s</p> <p>The forward and reverse dead zone time refers to the transition interval for which the drive waits at the output zero frequency for the transition from the current operating direction to the opposite operating direction after receiving the reverse run command, shown as t1 in the figure.</p> 	0.01s	0.01s	×
F2.31	Terminal Jog	0: Enable 1: Disable			
F2.32	Zero frequency thresholds	Setting range: 0.00~650.00Hz			

Parameter Code	Parameter name	Parameter detailed description	Minimum Unit	Factory value	Change																																												
F2.33	Display selection	LED units digit: quick parameter display selection 0: Display 6 quick parameters. check Chapter 3 for details 1: Display 1 quick parameter, determined by FC.17 LED tens digit: U group display selection 0: Display group U 1: Group U is not displayed																																															
F3 group: Motor and torque control parameters																																																	
F3.00	Motor model code	Set range: 1~28 The motor model code indicates the power code. Partial codes are as follows: <table border="1" style="margin-left: 20px;"> <thead> <tr> <th>Model code</th> <th>Motor power</th> </tr> </thead> <tbody> <tr><td>8</td><td>4T 5.5kW</td></tr> <tr><td>9</td><td>4T 7.5kW</td></tr> <tr><td>10</td><td>4T 11.0kW</td></tr> <tr><td>11</td><td>4T 15.0kW</td></tr> <tr><td>12</td><td>4T 18.5kW</td></tr> <tr><td>13</td><td>4T 22.0kW</td></tr> <tr><td>14</td><td>4T 30.0kW</td></tr> <tr><td>15</td><td>4T 37.0kW</td></tr> <tr><td>16</td><td>4T 45.0kW</td></tr> <tr><td>17</td><td>4T 55.0kW</td></tr> <tr><td>18</td><td>4T 75.0kW</td></tr> <tr><td>19</td><td>4T 90.0kW</td></tr> <tr><td>20</td><td>4T 110kW</td></tr> <tr><td>21</td><td>4T 132kW</td></tr> <tr><td>22</td><td>4T 160kW</td></tr> <tr><td>23</td><td>4T 185kW</td></tr> <tr><td>24</td><td>4T 200kW</td></tr> <tr><td>25</td><td>4T 220kW</td></tr> <tr><td>26</td><td>4T 250kW</td></tr> <tr><td>27</td><td>4T 280kW</td></tr> <tr><td>28</td><td>4T 315kW</td></tr> </tbody> </table> Note: 1. When the factory value is restored, this function code will be restored to the default parameters the same as the drive power. 2. When this function code is reset, F3.01~F3.10 motor parameters can be initialized.	Model code	Motor power	8	4T 5.5kW	9	4T 7.5kW	10	4T 11.0kW	11	4T 15.0kW	12	4T 18.5kW	13	4T 22.0kW	14	4T 30.0kW	15	4T 37.0kW	16	4T 45.0kW	17	4T 55.0kW	18	4T 75.0kW	19	4T 90.0kW	20	4T 110kW	21	4T 132kW	22	4T 160kW	23	4T 185kW	24	4T 200kW	25	4T 220kW	26	4T 250kW	27	4T 280kW	28	4T 315kW	1	Model determination	×
Model code	Motor power																																																
8	4T 5.5kW																																																
9	4T 7.5kW																																																
10	4T 11.0kW																																																
11	4T 15.0kW																																																
12	4T 18.5kW																																																
13	4T 22.0kW																																																
14	4T 30.0kW																																																
15	4T 37.0kW																																																
16	4T 45.0kW																																																
17	4T 55.0kW																																																
18	4T 75.0kW																																																
19	4T 90.0kW																																																
20	4T 110kW																																																
21	4T 132kW																																																
22	4T 160kW																																																
23	4T 185kW																																																
24	4T 200kW																																																
25	4T 220kW																																																
26	4T 250kW																																																
27	4T 280kW																																																
28	4T 315kW																																																
F3.01	Rated power	F3.01 set range: 0.4~999.9kW F3.02 set range: 0.1~6553.5A F3.03 set range: 1~65535rpm	0.1kW	Model determination	×																																												

Chapter IV Function Parameter Table

Parameter Code	Parameter name	Parameter detailed description	Minimum Unit	Factory value	Change
F3.02	Rated current	F3.04 set range: 1.00~650.00Hz F3.05 set range: 1~480V 1. Set the parameters of the controlled asynchronous motor.	0.1A		×
F3.03	Rated speed	2. In order to ensure the control performance, make sure to set the values of F3.01~F3.05 correctly according to the nameplate parameters of the asynchronous motor.	1rpm		×
F3.04	Rated frequency	3. This drive provides parameter self-tuning function. The accurate parameter self-tuning comes from the accurate settings of the motor nameplate parameters.	0.01Hz		×
F3.05	Rated voltage	4. In order to ensure the control performance, please configure the motor according to the standard adapter motor of the drive. If the gap between the motor power and the standard adapter motor is too large, the control performance of the drive will decrease significantly.	1V		×
F3.06	No-load current I0	F3.06 set range: 0.1~6553.5A F3.07 set range: 0.000~50.000Ω	0.1A		×
F3.07	Stator resistance R1	F3.08 set range: 0.0~6553.5mH F3.09 set range: 0.000~50.000Ω F3.10 set range: 0.0~6553.5mH	0.001Ω	Model determination	○
F3.08	Leakage inductance X	1. After changing the motor model code F3.00, the drive automatically sets the parameters of F3.06~F3.10 to the parameters of the corresponding motor.	0.1mH		○
F3.09	Rotor resistance R2	2. If the parameters of the motor are known, please write the values in F3.06~F3.10 accordingly. If the motor parameter self-tuning is performed, the set values of F3.06~F3.10 will be updated automatically after the tuning is completed normally.	0.001Ω		○
F3.10	Mutual inductance Xm	3. These parameters are the reference parameters for drive control and have direct impact on control performance. Note: Users shall not change this group of parameters at random.	0.1mH		○
F3.11	Motor poles	2~14	2		4

Parameter Code	Parameter name	Parameter detailed description	Minimum Unit	Factory value	Change
F3.12	Parameter self-tuning	<p>0: No action 1: Action (motor rotation): Perform comprehensive self-tuning of motor parameters. It is recommended to use rotary self-tuning for occasions with high control accuracy requirements. Note: Before starting the self-tuning, make sure that the motor is stopped and remove the load form motor shaft, otherwise the self-tuning cannot be performed normally. Parameter self-tuning steps: 1. According to the characteristics of the motor, set the function codes “F3.01 rated power” and “F3.02 rated current”, “F3.03 rated speed”, “F3.04 rated frequency”, “F3.05 rated voltage”, and “F3.11 motor poles” correctly. 2. Set F3.12 to 1, press the ENT key, and then press the RUN key to start parameter self-tuning. In this case, the keypad displays “STU--”. 3. When the keypad no longer displays “STU--”, it indicates that the parameter self-tuning is completed, and the set value of F3.12 will be set to 0 automatically.</p>	1	0	×
F3.13	Self-tuning acceleration and deceleration speeds	<p>0.01~600.00s Set acceleration/deceleration time during self-tuning no-load test.</p>	0.01s	Model determination	○
F3.14	Self-tuning current	<p>1~100% motor rated current Set the current during self-tuning DC test.</p>	1%	25%	×
F5 group: Analog terminal parameters					
F5.00	All minimum value	<p>F5.00 set range: 0.00~F5.02 F5.01 set range: -100.0%~100.0% F5.02 set range: F5.00~10.00V</p>	0.01V	0.00V	○
F5.01	Set value corresponding to All minimum value	<p>F5.03 set range: -100.0%~100.0% F5.04 set range: 0.00~10.00V F5.05 set range: 0~1000ms F5.06 set range: 0.00~F5.08 F5.07 set range: -100.0%~100.0%</p>	0.1%	0.0%	○
F5.02	All maximum value	<p>F5.08 set range: F5.06~10.00V F5.09 set range: -100.0%~100.0% F5.10 set range: 0.00~10.00V</p>	0.01V	10.00V	○

Parameter Code	Parameter name	Parameter detailed description	Minimum Unit	Factory value	Change	
F5.03	Set value corresponding to AI1 maximum value	<p>F5.11 set range: 0~1000ms</p> <p>1. The function code defines the relationship between the analog input voltage and the corresponding set value of the analog input. When the analog input voltage exceeds the set maximum or minimum input range, it will be calculated with the maximum or minimum input.</p> <p>2. When analog input is current input, a current of 0~20mA corresponds to a voltage of 0~10V.</p> <p>3. In different applications, the nominal values corresponding to the analog setting 100.0% are different, please refer to the instructions of applications for details. The following legend illustrates the different settings:</p>	0.1%	100.0%	○	
F5.04	AI1 zero drift setting		0.01V	0.00V	○	
F5.05	AI1 filter time		1ms	10ms	○	
F5.06	AI2 minimum value		0.01V	0.00V	○	
F5.07	Set value corresponding to AI2 minimum value		0.1%	0.0%	○	
F5.08	AI2 maximum value		0.01V	10.00V	○	
F5.09	Set value corresponding to AI2 maximum value		0.1%	100.0%	○	
F5.10	AI2 zero drift setting		0.01V	0.00V	○	
F5.11	AI2 filter time		<p>4. Filter time of analog input: Adjust the sensitivity of the analog input. Increasing this value appropriately can enhance the anti-interference of the analog quantity, but will weaken the sensitivity of the analog input.</p> <p>5. Analog zero drift setting: Generally, there will be some zero drift in the analog quantity. On some occasions with high accuracy requirements, the zero drift setting will achieve a better corresponding effect.</p> <p>Note: Analog AI1 supports 0~10V/0~20mA input (selected by jumper J1), and analog AI2 supports 0~10V/0~20mA input (selected by jumper J2).</p>	1ms	10ms	○
F5.12	Reserved		-	-	*	
F5.13	Reserved	-	-	*		
F5.14	Reserved	-	-	*		
F5.15	Reserved	-	-	*		

Parameter Code	Parameter name	Parameter detailed description	Minimum Unit	Factory value	Change
F5.16	Reserved	-	-	-	*
F5.17	Reserved	-	-	-	*
F5.18	Analog automatic zero drift adjustment	Set range: 0~1 When set to 1, the automatic zero drift adjustment of the analog quantity must be performed. It must be ensured that there is no external analog input quantity input.	0	0	○
F5.19	PULSE minimum input	0.00~F5.21	0.01KHz	0.00KHz	○
F5.20	Corresponding setting of PULSE minimum input	-100.0%~100.0%	0.1%	0.0%	○
F5.21	PULSE maximum input	F5.19~50.00KHz	0.01KHz	50.00KHz	○
F5.22	Corresponding setting of PULSE maximum input	-100.0%~100.0%	0.1%	100.0%	○
F5.23	PULSE filter time	0~1000ms	1ms	10ms	○
F5.24	HDO function selection	0: Running frequency (0~Maximum output frequency) 1: Set frequency (0~Maximum output frequency) 2: Output current (0~2 times rated current)	1	5	○
F5.25	AO1 function selection	3: Output torque (0~2 times rated torque) 4: Output voltage (0~1.2 times rated voltage)	1	0	○
F5.26	AO2 function selection	5: Bus voltage (0~1000V) 6: AI1 (0~10V/0~20mA) 7: AI2 (0~10V/0~20mA) 8: Reserved 9: Output power (0~2 times rated frequency) 10: Pulse input (0~50.00KHz) 11: Communication setting (0~F1.06) 12: Operating frequency after compensation (0~maximum output frequency)	1	1	○
F5.27	HDO output lower limit	F5.27 set range: 0.0~F5.29 F5.28 set range: 0.00~50.00KHz	0.1%	0.0%	○

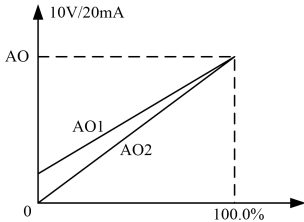
Parameter Code	Parameter name	Parameter detailed description	Minimum Unit	Factory value	Change
F5.28	HDO output frequency corresponding to lower limit	F5.29 set range: F5.27~100.0% F5.30 set range: 0.00~50.00KHz F5.31 set range: 0.0~F5.33 F5.32 set range: 0.00~10.00V F5.33 set range: F5.31~100.0%	0.01KHz	0.00KHz	○
F5.29	HDO output upper limit	F5.34 set range: 0.00~10.00V F5.35 set range: 0.0~F5.37 F5.36 set range: 0.00~10.00V	0.1%	100.0%	○
F5.30	HDO output frequency corresponding to upper limit	F5.37 set range: F5.35~100.0% F5.38 set range: 0.00~10.00V 1. The function code defines the corresponding relationship between the output value and the analog output. When the output value exceeds the set maximum output or minimum output range, it will be calculated as either upper limit output or lower limit output.	0.01KHz	50.00KHz	○
F5.31	AO1 output lower limit	2. When the analog output is current output, 1mA current is equivalent to 0.5V voltage.	0.1%	0.0%	○
F5.32	AO1 output voltage corresponding to lower limit	3. In different applications, the analog output corresponding to 100% of the output value is different. The following legend illustrates the different settings:	0.01V	0.00V	○
F5.33	AO1 output upper limit	 <p style="text-align: center;">10V/20mA</p>	0.1%	100.0%	○
F5.34	AO1 output voltage corresponding to upper limit		0.01V	10.00V	○
F5.35	AO2 output lower limit		0.1%	0.0%	○
F5.36	AO2 output voltage corresponding to lower limit		0.01V	0.00V	○
F5.37	AO2 output lower limit		0.1%	100.0%	○
F5.38	AO2 output voltage corresponding to upper limit		0.01V	10.00V	○
F5.39	Reserved	-	-	-	*
F5.40	Reserved	-	-	-	*

Parameter Code	Parameter name	Parameter detailed description	Minimum Unit	Factory value	Change
F6 group: Digital terminal parameters					
F6.00	Function selection of multi-function input terminal DI1	0: No function 1: Forward running FWD (edge+ level) 2: Reverse running REV (edge+ level) 3: Three-wire control Sin (level) 4: Forward jog (level) 5: Reverse jog (level) 6: Free stop (level) 7: Fault reset (edge signal) 8: Run pause (level) 9: External fault input 10: Frequency setting increase (UP) 11: Frequency setting decreases (DOWN) 12: Multistage speed terminal 1 13: Multistage speed terminal 2 14: Multistage speed terminal 3 15: Multistage speed terminal 4 16: Acceleration/deceleration time selection 1 17: Acceleration/deceleration time selection 2 18: PLC pause 19: PLC operation stop and reset 20: PID control pause 21: PID parameter switching 22: Counter trigger 23: Counter reset 24: Length reset	1	1	×
F6.01	Function selection of multi-function input terminal DI2	25: Acceleration/deceleration prohibited (level) 26: Immediate DC braking 27: UP/DOWN setting cleared 28: Control command switched to keypad 29: Control command switched to terminal 30: Control command switched to communication		2	
F6.02	Function selection of multi-function input terminal DI3	31: Frequency source switched to the main frequency X 32: Frequency source switched to auxiliary frequency Y 33: High-frequency pulse count reset 34: reserved 35: Water shortage signal 36: reserved 37: reserved 38: Fire override mode 39: Pump A maintenance signal 40: Pump B maintenance signal		7	

Parameter Code	Parameter name	Parameter detailed description	Minimum Unit	Factory value	Change
F6.03	Function selection of multi-function input terminal DI4	41: Pump C maintenance signal Note: The function assigned to different terminals cannot be the same. If the functions of the two terminals are set to the same, the DI ports ranked first will work first, and the latter ones will not work. Detailed description of terminal functions: 1~3: Forward running FWD, reverse running REV, three-wire running control Sin: For terminal two-wire and three-wire control signals, see function code F6.09 description for details.		12	
F6.04	Function selection of multi-function input terminal DI5	4~5: Forward jog and reverse jog: Used for jog running control under terminal run command mode, the jog running frequency, jog interval time and jog acceleration/deceleration time are defined in F2.20~F2.23. 6: Free stop: If the function of this terminal is valid, the drive immediately terminates the output, and the load stops freely according to its mechanical inertia. 7: Fault reset: When a fault alarm occurs in the drive, the fault can be reset through this terminal. Its function is consistent with the STOP key function of the keypad.		13	
F6.05	Multi-function input terminal DI6 function selection (expansion card)	8: Running pause: If this terminal is valid during running, the drive will decelerate to zero frequency running according to the deceleration time. This function is invalid during jog running. 9: External fault input: The fault signals of external devices can be input through this terminal, which is convenient for the drive to monitor the faults of external devices. After receiving fault signals from external devices, the drive displays "E015", which is the fault alarm of external devices.		0	
F6.06	Multi-function input terminal DI7 function selection (expansion card)	10~11: Frequency setting increase UP, and frequency setting decrease DOWN: The frequency increase or decrease is realized through the control terminal, to perform remote control replacing the keypad. It is effective when the main frequency F1.02 = 2 or the auxiliary frequency F1.03 = 2, the acceleration/deceleration rate is set by F6.10. 12~15: Multistage speed terminals 1~4: By selecting the terminal ON/OFF		0	

Parameter Code	Parameter name	Parameter detailed description	Minimum Unit	Factory value	Change																																								
F6.07	Multi-function input terminal DI8 function selection (expansion card)	combination of these functions, you can define up to 16 stages of multi-speed running. The frequency of multistage instructions, acceleration/deceleration time, and the rotating direction are set in group F9.		0																																									
		<table border="1"> <thead> <tr> <th>K4</th> <th>K3</th> <th>K2</th> <th>K1</th> <th>Frequency setting</th> </tr> </thead> <tbody> <tr> <td>OFF</td> <td>OFF</td> <td>OFF</td> <td>OFF</td> <td>Multistage instruction 1</td> </tr> <tr> <td>OFF</td> <td>OFF</td> <td>OFF</td> <td>ON</td> <td>Multistage instruction 2</td> </tr> <tr> <td>OFF</td> <td>OFF</td> <td>ON</td> <td>OFF</td> <td>Multistage instruction 3</td> </tr> <tr> <td>OFF</td> <td>OFF</td> <td>ON</td> <td>ON</td> <td>Multistage instruction 4</td> </tr> <tr> <td>OFF</td> <td>ON</td> <td>OFF</td> <td>OFF</td> <td>Multistage instruction 5</td> </tr> <tr> <td>OFF</td> <td>ON</td> <td>OFF</td> <td>ON</td> <td>Multistage instruction 6</td> </tr> <tr> <td>OFF</td> <td>ON</td> <td>ON</td> <td>OFF</td> <td>Multistage instruction 7</td> </tr> </tbody> </table>	K4			K3	K2	K1	Frequency setting	OFF	OFF	OFF	OFF	Multistage instruction 1	OFF	OFF	OFF	ON	Multistage instruction 2	OFF	OFF	ON	OFF	Multistage instruction 3	OFF	OFF	ON	ON	Multistage instruction 4	OFF	ON	OFF	OFF	Multistage instruction 5	OFF	ON	OFF	ON	Multistage instruction 6	OFF	ON	ON	OFF	Multistage instruction 7	
		K4	K3			K2	K1	Frequency setting																																					
		OFF	OFF			OFF	OFF	Multistage instruction 1																																					
		OFF	OFF			OFF	ON	Multistage instruction 2																																					
		OFF	OFF			ON	OFF	Multistage instruction 3																																					
		OFF	OFF			ON	ON	Multistage instruction 4																																					
		OFF	ON			OFF	OFF	Multistage instruction 5																																					
OFF	ON	OFF	ON	Multistage instruction 6																																									
OFF	ON	ON	OFF	Multistage instruction 7																																									
F6.08	Reserved	OFF	ON	ON	ON	Multistage instruction 8																																							
		ON	OFF	OFF	OFF	Multistage instruction 9																																							
		ON	OFF	OFF	ON	Multistage instruction 10																																							
		ON	OFF	ON	OFF	Multistage instruction 11																																							
		ON	OFF	ON	ON	Multistage instruction 12																																							
		ON	ON	OFF	OFF	Multistage instruction 13																																							
		ON	ON	OFF	ON	Multistage instruction 14																																							
		ON	ON	ON	OFF	Multistage instruction 15																																							
		ON	ON	ON	ON	Multistage instruction 16																																							
		16~17: Acceleration/deceleration time selection 1~2: The ON/OFF combination of acceleration/deceleration time terminals 1 and 2 can realize the selection of acceleration/deceleration time 1~4.																																											
			K2	K1	Acceleration/deceleration time selection																																								
			OFF	OFF	Acceleration/deceleration time 1																																								
			OFF	ON	Acceleration/deceleration time 1																																								
			ON	OFF	Acceleration/deceleration time 3																																								
			ON	ON	Acceleration/deceleration time 4																																								

Parameter Code	Parameter name	Parameter detailed description	Minimum Unit	Factory value	Change
		<p>18: PLC pause: Used to pause the running PLC process. When this terminal is valid, drive runs at zero frequency. The PLC running is not counted.</p> <p>19: PLC running stop and reset: PLC is prohibited from starting when the terminal is valid, deceleration and stop control is implemented for the PLC running process, and the PLC is reset to the initial state.</p> <p>20: PID control pause: PID is temporarily pause, and the drive maintains the current output frequency without performing PID adjustment.</p> <p>21: PID parameter switching: When the PID parameter switching condition (F8.12) is set to 1 (via terminal switching), the F8.06~F8.08 are used for PID parameters when the terminal is invalid, and F8.09~F8.11 are used when the terminal is valid.</p> <p>22: Counter trigger: Count pulse input port of the built-in counter, the highest pulse frequency: 200Hz, and the current count value is stored when power is off. See function codes F6.22 and F6.23 for details.</p> <p>23: Counter reset: Clear the built-in counter of the drive and use it in conjunction with function 22 (counter trigger signal input).</p> <p>24: Length reset: When the function terminal is valid, the actual length is cleared to zero.</p> <p>25: Acceleration/deceleration prohibition: Keep the motor from being affected by any external signal (except stop command), and maintain operation at the current speed. This function is invalid during jog running.</p> <p>26: Immediate DC brake: When the stop mode is deceleration stop + DC braking" (F2.08=2), it applies DC brake when a valid signal is given to this terminal.</p> <p>27: UP/DOWN setting is cleared: When the frequency input channel is set to terminal UP/DN, this function terminal can directly clear the frequency set by</p>			

Parameter Code	Parameter name	Parameter detailed description	Minimum Unit	Factory value	Change
		<p>UP/DN.</p> <p>28: Control command switch to keypad 29: Control command switch to terminal 30: Control command switch to communication</p> <p>If the above three terminals or two of them are closed at the same time, the priority is keypad> terminal> communication.</p> <p>Note: When switching to terminal two-wire control, the running state changes are affected by the F2.06 parameter; when switching to other control modes, the current running state is maintained.</p> <p>31: Switch frequency mode to main frequency X 32: Switch frequency mode to auxiliary frequency Y</p> <p>If the above two terminals are closed at the same time, the priority of switching to the main frequency X> switching to the auxiliary frequency Y</p> <p>33: High-frequency pulse count reset: The high-frequency pulse count value recorded by function code U0.16 is cleared.</p> <p>34: reserved</p> <p>35: Water shortage failure: The terminal reports E023 water supply failure when “special drive for water supply” is selected (F0.04=2).</p> <p>36: reserved</p> <p>37: reserved</p> <p>38: Fire override mode: When the fire override mode signal is valid, the drive cannot be stopped except for power failure.</p>			
F6.09	Forward/reverse running mode setting	<p>0: Two-wire control mode 1: This mode is the most commonly used two-wire mode. The forward and reverse direction of the motor can be changed using defined FWD and REV terminals.</p>	1	0	×

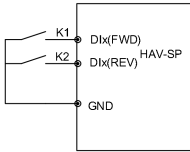
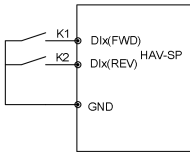
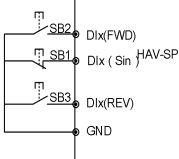
Parameter Code	Parameter name	Parameter detailed description	Minimum Unit	Factory value	Change																																														
		<table border="1" style="display: inline-table; margin-right: 20px;"> <thead> <tr> <th>K2</th> <th>K1</th> <th>Run command</th> </tr> </thead> <tbody> <tr> <td>0</td> <td>0</td> <td>Stop</td> </tr> <tr> <td>1</td> <td>0</td> <td>REV</td> </tr> <tr> <td>0</td> <td>1</td> <td>FWD</td> </tr> <tr> <td>1</td> <td>1</td> <td>Stop</td> </tr> </tbody> </table>  <p>1: Two-wire control mode 2: This mode uses the defined FWD as the running terminal and the direction is determined by the defined REV terminal.</p> <table border="1" style="display: inline-table; margin-right: 20px;"> <thead> <tr> <th>K2</th> <th>K1</th> <th>Run command</th> </tr> </thead> <tbody> <tr> <td>0</td> <td>0</td> <td>Stop</td> </tr> <tr> <td>1</td> <td>0</td> <td>Stop</td> </tr> <tr> <td>0</td> <td>1</td> <td>FWD</td> </tr> <tr> <td>1</td> <td>1</td> <td>REV</td> </tr> </tbody> </table>  <p>2: Three-wire control mode 1: This mode uses the defined Sin as the enable terminal, the run command is generated by FWD or REV, and both also motor direction. When the drive operates, the terminal Sin must be closed. The terminal FWD or REV needs a rising edge signal to control the operation and direction of the drive. When the drive stops, the terminal Sin must be disconnected to complete the stop.</p> <table border="1" style="display: inline-table; margin-right: 20px;"> <thead> <tr> <th>SB3</th> <th>SB2</th> <th>SB1</th> <th>Run command</th> </tr> </thead> <tbody> <tr> <td>X</td> <td>X</td> <td>0</td> <td>Stop</td> </tr> <tr> <td>X</td> <td>↑</td> <td>1</td> <td>FWD</td> </tr> <tr> <td>↑</td> <td>X</td> <td>1</td> <td>REV</td> </tr> </tbody> </table>  <p>3: Three-wire control mode 2: This mode uses the defined Sin as the enable terminal, the run command is generated by FWD, and the direction is controlled by REV. When the drive operates, the terminal Sin must be closed. The FWD terminal needs a rising edge signal to start</p>	K2	K1	Run command	0	0	Stop	1	0	REV	0	1	FWD	1	1	Stop	K2	K1	Run command	0	0	Stop	1	0	Stop	0	1	FWD	1	1	REV	SB3	SB2	SB1	Run command	X	X	0	Stop	X	↑	1	FWD	↑	X	1	REV			
K2	K1	Run command																																																	
0	0	Stop																																																	
1	0	REV																																																	
0	1	FWD																																																	
1	1	Stop																																																	
K2	K1	Run command																																																	
0	0	Stop																																																	
1	0	Stop																																																	
0	1	FWD																																																	
1	1	REV																																																	
SB3	SB2	SB1	Run command																																																
X	X	0	Stop																																																
X	↑	1	FWD																																																
↑	X	1	REV																																																

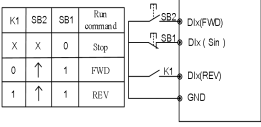
Parameter Code	Parameter name	Parameter detailed description	Minimum Unit	Factory value	Change																
		<p>the motor. The REV terminal determines the operation direction. When the drive stops, the Sin terminal must be disconnected to complete the stop.</p>  <table border="1" data-bbox="376 279 502 391"> <tr> <td>K1</td> <td>SB2</td> <td>SB1</td> <td>Run command</td> </tr> <tr> <td>X</td> <td>X</td> <td>0</td> <td>Stop</td> </tr> <tr> <td>0</td> <td>↑</td> <td>1</td> <td>FWD</td> </tr> <tr> <td>1</td> <td>↑</td> <td>1</td> <td>REV</td> </tr> </table> <p>The diagram shows a terminal block with terminals m, SB2, SB1, K1, and GND. Connections are: m to DIn(FWD), SB2 to DIn(Sin), SB1 to DIn(REV), and K1 to DIn(REV). GND is the common ground.</p>	K1	SB2	SB1	Run command	X	X	0	Stop	0	↑	1	FWD	1	↑	1	REV			
K1	SB2	SB1	Run command																		
X	X	0	Stop																		
0	↑	1	FWD																		
1	↑	1	REV																		
F6.10	UP/DN rate	<p>0.01~99.99Hz/s This function code defines the change rate of the set frequency modified by the UP/DN terminal.</p>	0.01Hz/s	1.00Hz/s	○																
F6.11	Open collector output terminal DO1	<p>0: No output 1: Drive running signal (RUN) 2: Frequency arrival signal (FAR) 3: Frequency level detection signal (FDT1) 4: Frequency level detection signal (FDT2) 5: Overload detection signal(OL) 6: Undervoltage lockout stopping (LU) 7: External fault stop (EXT)</p>	1	0	×																
F6.12	Open collector output terminal DO (HDO terminal)	<p>8: Frequency upper limit (FHL) 9: Frequency lower limit (FLL) 10: Drive running at zero frequency 11: PLC phase running completion 12: PLC cycle completion 13: Set count value arrival 14: Specified count value arrival 15: Set length arrival 16: Drive ready to run (RDY) 17: Drive fault 18: Reserved 19: Set cumulative running time arrival 20: Forward running 21: Reverse running 22: Reserved 23: Water supply sleep running indication 24: Water pipe overpressure indication 25: Water pipe under-pressure indication 26: Water pipe shortage indication 27: Water tank shortage indication</p>	1	1	×																

Parameter Code	Parameter name	Parameter detailed description	Minimum Unit	Factory value	Change
F6.13	Relay output function (TA/TB/TC)	<p>28: Water pipe break indication</p> <p>Detailed description of terminal functions:</p> <p>1: Drive running signal (RUN): Outputs an indication signal id the drive is running.</p> <p>2: Frequency arrival signal (FAR): Refer to the function description of F6.18.</p> <p>3: Frequency level detection signal (FDT1): Refer to the function description of F6.14~F6.15.</p> <p>4: Frequency level detection signal (FDT2): Refer to the function description of F6.16~F6.17.</p> <p>5: Overload detection signal (OL): If the output current of the drive exceeds the FA.15 overload detection level, it outputs an indication signal after FA.16 overload detection time.</p> <p>6: Undervoltage lockout stopping (LU): When the DC bus voltage is lower than the under-voltage limit level, it outputs an indication signal, and the LED displays "P.oFF"</p> <p>7: External fault stop (EXT): When the drive has an external fault trip alarm (E015), it outputs an indication signal.</p> <p>8: Frequency upper limit (FHL): When the set frequency \geq the upper limit frequency and the operation frequency reaches the upper limit; an indication signal is output.</p> <p>9: Frequency lower limit (FLL): When the set frequency \leq the lower limit frequency and the operation frequency reaches the lower limit; an indication signal is output.</p> <p>10: Drive running at zero frequency: Output frequency \leq FC.10 zero frequency arrival range, it outputs an indication signal under operation status.</p> <p>11: PLC phase operation completed: After a single stage of simple PLC operation is completed, an indication signal (single pulse signal, width is 250ms) is output.</p> <p>12: PLC cycle completed: After the simple PLC completes one complete cycle, an indication signal (single pulse signal, width is 250ms) is output.</p> <p>13: Set count value arrival</p> <p>14: Specified count value arrival</p> <p>For functions 13~14, refer to F6.22~F6.23 function description.</p> <p>15: Set length arrival: When the actual length $U0.15 \geq FC.11$ set length, an</p>	1	17	×

Parameter Code	Parameter name	Parameter detailed description	Minimum Unit	Factory value	Change
		<p>indication signal is output.</p> <p>16: Drive ready to run (RDY): When the drive has no fault, the bus voltage is normal, and no signal is given at the drive operation prohibition terminal, it outputs an indication signal. In this case, the drive indicates that the start command can be given to the drive.</p> <p>17: Drive fault: If the drive fails, an indication is output.</p> <p>18: Reserved</p> <p>19: Set the accumulated running time arrival: When the accumulated running time of the drive (U0.27) reaches the running cutoff time (F0.02) of the drive, an indication signal is output.</p> <p>20: Forward running indication: Outputs an indication signal when drive is running in forward direction.</p> <p>21: Reverse running indication: Outputs an indication signal when drive is running in reverse direction.</p> <p>22: Reserved</p> <p>23: Water supply sleep indication: During water supply application, output an indication signal if the drive is in sleep mode.</p> <p>24: Water pipe overpressure indication: During water supply application, output a signal if the water pipe is in overpressure state at any time.</p> <p>25: Water pipe under-pressure indication: During water supply application, output a signal if the water pipe is in under-pressure state at any time.</p> <p>26: Water pipe shortage indication: During water supply application, if the drive finds that the water pipe is in short of water at any time, it outputs an indication signal.</p> <p>27: Water tank shortage indication: During water supply application, if the drive finds that the water tank is in short of water at any time, it outputs an indication signal.</p> <p>28: Water pipe burst indication: During water supply application, if the drive finds that the water pipe burst at any time, it outputs an indication signal.</p>			

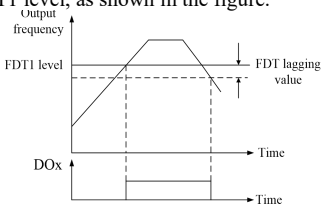
Parameter Code	Parameter name	Parameter detailed description	Minimum Unit	Factory value	Change
F6.14	FDT1 level	F6.14 set range: 0.00~650.00Hz F6.15 set range: 0.00~650.00Hz F6.16 set range: 0.00~650.00Hz F6.17 set range: 0.00~650.00Hz F6.14~F6.15 are supplementary definitions for No. 3 function FDT1 in the terminal output function, F6.16~F6.17 are supplementary definitions for No. 4 function FDT2 in the terminal output function. The usage of both is the same. In the following, In the below example, F6.14~F6.15 are taken as an example:	0.01Hz	50.00Hz	○
F6.15	FDT1 lag	When the output frequency is greater than or equal to a certain set frequency (FDT1 level), it outputs an indication signal until the output frequency drops to a frequency (FDT1 level - FDT1 lag) lower than FDT1 level, as shown in the figure.	0.01Hz	1.00Hz	○
F6.16	FDT2 level	When the output frequency is greater than or equal to a certain set frequency (FDT1 level), it outputs an indication signal until the output frequency drops to a frequency (FDT1 level - FDT1 lag) lower than FDT1 level, as shown in the figure.	0.01Hz	25.00Hz	○
F6.17	FDT2 lag		0.01Hz	1.00Hz	○
F6.18	Frequency arrival (FAR) detection width	0.00~650.00Hz This parameter is a supplementary definition for No. 2 function in the terminal output function. As shown in the figure, when the output frequency of the drive is within the positive and negative detection widths of the set frequency, a pulse signal is output.	0.01Hz	2.50Hz	○
F6.19	HDI terminal input	0: Switch input 1: High-frequency pulse input (see F5.19~F5.23)	1	0	×

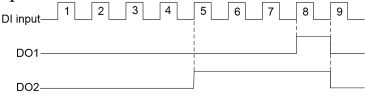
Parameter Code	Parameter name	Parameter detailed description	Minimum Unit	Factory value	Change
	mode selection (DI5)				
F6.20	HDO terminal output mode selection (DO2)	0: Switch output 1: High-frequency pulse output (see F5.27~F5.30)	1	0	×
F6.21	Reserved	-	-	-	*
F6.22	Counter reset value setting (set count value arrival)	F6.22 set range: F6.23~9999 F6.23 set range: 0~F6.22 F6.22 and F6.23 are supplementary definitions for No. 13 and No. 14 functions in the terminal output function. 1. The set count value input refers to the number of input pulses from DIx (count trigger signal input function terminal), before the DOx (open collector output terminal) or the relay outputs an indication signal. As shown in the figure, when DIx inputs the 8th pulse, DO1 outputs an indication signal, and F6.22 = 8 in this case. 2. The specified count value input refers to the number of input pulses from DIx, before the DOx or the relay outputs an indication signal, till the set count value is reached. As shown in the figure, when DIx inputs the 5th pulse, DO2 outputs an indication signal, till the set count value 8 is reached, in this case F6.23 = 5. 3. When the specified count value is greater than the set count value, the specified count value is invalid.	1	0	○
F6.23	Counter detection value setting (specified count value arrival)	1. The set count value input refers to the number of input pulses from DIx (count trigger signal input function terminal), before the DOx (open collector output terminal) or the relay outputs an indication signal. As shown in the figure, when DIx inputs the 8th pulse, DO1 outputs an indication signal, and F6.22 = 8 in this case. 2. The specified count value input refers to the number of input pulses from DIx, before the DOx or the relay outputs an indication signal, till the set count value is reached. As shown in the figure, when DIx inputs the 5th pulse, DO2 outputs an indication signal, till the set count value 8 is reached, in this case F6.23 = 5. 3. When the specified count value is greater than the set count value, the specified count value is invalid. 	1	0	○
F6.24	DI polarity switch 1	00000~11111 LED single digit: DI1 polarity LED tenth digit: DI2 polarity LED hundredth digit: DI3 polarity LED thousandth digit: DI4 polarity LED 10 thousandth digit: DI5 polarity This function code is used to set the polarity of the digital input. When the bit is set to 1, the input polarity is positive (connected to the common terminal is valid and disconnected is invalid). When the bit is set to 0, the input polarity is	11111	11111	○

Parameter Code	Parameter name	Parameter detailed description	Minimum Unit	Factory value	Change
		negative (connected with the common terminal is invalid, disconnected is valid).			
F6.25	DI polarity switch 2	00000~11111 LED unit digit: DI6 polarity (expansion card) LED tenth digit: DI7 polarity (expansion card) LED hundredth digit: DI8 polarity (expansion card) LED thousandth digit: reserved LED ten thousandth digit: reserved This function code is used to set the polarity of the digital input. When the bit is set to 1, the input polarity is positive (connected to the common terminal is valid and disconnected is invalid). When the bit is set to 0, the input polarity is negative (connected with the common terminal is invalid, disconnected is valid).	11111	11111	○
F6.26	DO output switch polarity 1	00000~11111 LED single digit: DO1 positive/negative logic definition LED tens digit: DO2 positive/negative logic definition LED hundreds digit: Relay positive/negative logic definition LED thousands digit: Reserved LED 10 thousands digit: Reserved This function code is used to set the polarity of the output switch. When the bit is set to 1, the output switch is positive logic, when the bit is set to 0, the output switch is negative logic.	11111	11111	○
F6.27	Reserved	-	-	-	*
F6.28	DI filter time	0~1000ms Set DI1 ~DI5 common terminal function input filter time. In the case of large interference, you shall increase the set value of this function code to prevent mis-operation.	1ms	5ms	○
F6.29	DO1 output on delay	Set range: 0.0~600.0s This function code defines the delay from the status change of the switch output terminal and the relay to the output change.	0.1s	0.0s	○
F6.30	DO1 output off delay		0.1s	0.0s	○
F6.31	DO2 output on delay		0.1s	0.0s	○
F6.32	DO2		0.1s	0.0s	○

Parameter Code	Parameter name	Parameter detailed description	Minimum Unit	Factory value	Change
F6.33	output off delay		0.1s	0.0s	○
	Relay output on delay				
F6.34	Relay output off delay		0.1s	0.0s	○
F6.35	Relay 2 function selection (expansion card)	Same as F6.11	1	0	×
F6.36	Relay 2 output delay time (expansion card)	Setting range: 0.0~600.0s	0.1s	0.0s	○
F7 group:Advanced function parameters					
F7.00	Overpressure stall point	F7.00 set range: 100.0~160.0%Udc F7.01 set range: 0.000~10.000V F7.02 set range: 0~1000 F7.03 set range: 1~1000ms 1. The overvoltage stall protection function detects the bus voltage during the decelerating operation of the drive and compares with the overvoltage stall point defined by F7.00 (relative to the standard bus voltage) and the overvoltage control voltage defined by F7.01 (relative to the bus voltage change rate), if the bus voltage exceeds the overvoltage stall point or the bus voltage change rate exceeds the overvoltage control voltage, the drive will adjust the deceleration time to make the output frequency slow down.	0.1% Udc	Model determination	○
F7.01	Overvoltage control voltage	function detects the bus voltage during the decelerating operation of the drive and compares with the overvoltage stall point defined by F7.00 (relative to the standard bus voltage) and the overvoltage control voltage defined by F7.01 (relative to the bus voltage change rate), if the bus voltage exceeds the overvoltage stall point or the bus voltage change rate exceeds the overvoltage control voltage, the drive will adjust the deceleration time to make the output frequency slow down.	0.001	5.000V	○
F7.02	Overvoltage stall gain Kp	exceeds the overvoltage control voltage, the drive will adjust the deceleration time to make the output frequency slow down.	1	5	○
F7.03	Overvoltage stall integration time	2. Overvoltage stall gain, and overvoltage stall integration time: Used to adjust the drive's ability to suppress overvoltage during deceleration. The larger the gain, and the longer the integration time, the stronger the ability to suppress overvoltage, and the drive's deceleration time becomes longer accordingly. So, under the premise of no overvoltage, the smaller the gain and the longer the integration time, the better the deceleration effect. Note: When the set stall point is low, it is suggested that the user shall increase the deceleration time appropriately.	1ms	200ms	○

Parameter Code	Parameter name	Parameter detailed description	Minimum Unit	Factory value	Change
F7.04	Overcurrent stall level	F7.04 set range: 80.0~230.0% F7.05 set range: 0~1 F7.06 set range: 0~1000 F7.07 set range: 1~1000ms 1. The overcurrent stall function is to automatically limit the overcurrent stall level (F7.04) not exceeding the setting, through the real-time control of the load current, to prevent fault trips caused by current overshoot. For load occasions with large inertia or intense changes, this function is especially suitable.	0.1%	180.0	○
F7.05	Overcurrent stall action selection	2. The overcurrent stall level (F7.04) defines the current threshold of the overcurrent stall action, and its setting range is relative to the percentage of the drive rated current. When this parameter value is exceeded, the drive starts to implement the overcurrent stall protection function.	1	1	○
F7.06	Overcurrent stall gain Kp	3. Overcurrent stall gain, and overcurrent stall integration time: Used to adjust the drive's ability to suppress overcurrent during acceleration and deceleration. The larger the gain, and the longer the integration time, the stronger the ability to suppress overcurrent, and the drive's acceleration/deceleration time becomes longer accordingly. So, under the premise of no overcurrent, the smaller the gain and the longer the integration time, the better the effect.	1	5	○
F7.07	Overcurrent stall integration time	4. The overcurrent stall function is always effective under the acceleration/deceleration status. Whether the overcurrent stall function is effective during constant speed operation is determined by the overcurrent stall action selection (F7.05). F7.05=0 overcurrent stall is invalid during constant speed operation; F7.05=1 overcurrent stall is valid during constant speed operation.	1ms	60ms	○
F7.08	Reserved		-	-	*
F7.09	Reserved		-	-	*
F7.10	Reserved		-	-	*
F7.11	Reserved		-	-	*
F7.12	Reserved		-	-	*
F7.13	Reserved	Reserved	-	-	*

Parameter Code	Parameter name	Parameter detailed description	Minimum Unit	Factory value	Change
F7.14	Reserved		-	-	*
F7.15	Reserved		-	-	*
F7.16	Reserved		-	-	*
F7.17	Reserved		-	-	*
F7.18	Reserved		-	-	*
F7.19	Reserved		-	-	*
F7.20	Overcurrent stall speed recovery time limit	Set range: 0.01~600.00s After the overcurrent stall is canceled, the drive output frequency will resume to the set frequency, but the fastest acceleration / deceleration time for recovery is limited by this function code.	0.01s	0.20s	○
F7.21	Torque boost limit	F7.21 set range: 0.1~30.0% F7.22 set range: 0.00~F3.04 F7.23 set range: 0~500 (when set to 0, it is manual torque boost) F7.24 set range: 1~10000ms	0.1%	4.0%	○
F7.22	Torque boost cutoff point	F7.25 set range: 0.00~F3.04 F7.26 set range: 0~500 F7.27 set range: 1~10000ms F7.28 set range: 0~100% 1. The torque boost is to compensate the output voltage of the drive when the drive is running at low frequency. The torque boost can improve the low frequency characteristics in V/F control mode.	0.01Hz	50.00Hz	○
F7.23	Torque boost gain 1	2. The torque boost amount shall be set appropriately according to the load. The load can increase the boost amount, but the boost amount shall not be set too large. When the torque boost is too large, the motor will run in over-excitation and the drive output current will increase. The motor heats up and the efficiency decreases.	1	20	○
F7.24	Torque boost integral time 1	3. Torque boost cutoff point: Below this frequency point, the torque boost is valid, and is invalid when the set frequency is exceeded.	1ms	1500ms	○
F7.25	Torque boost gain switching frequency point	4. Torque boost gain switching frequency point: Switching frequency point during high-speed and low-speed variable gains.	0.01Hz	Model determination	○
F7.26	Torque boost gain 2	5. Setting of the torque boost gain and integration time: Increasing the gain can	1	10	○

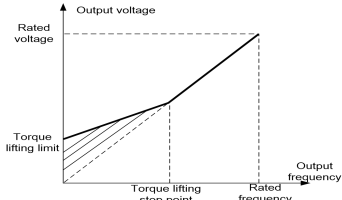
Parameter Code	Parameter name	Parameter detailed description	Minimum Unit	Factory value	Change
F7.27	Torque boost integral time 2	speed up the system's dynamic response, but if the gain is too large, the system is easy to generate oscillation; reducing the integration time can speed up the system's dynamic response, but if the integration is too small, the system overshoot is large and is easy to generate oscillation.	1ms	500ms	○
F7.28	Automatic torque boost factor	Usually, the proportional gain is adjusted first to maximize under the premise that the system is not oscillating; then the integration time is adjusted to make the system have a fast dynamic response and reduce the system overshoot. 	1%	30%	○
F7.29	Motor oscillation suppression methods	F7.29 set range: 0~1 F7.30 set range: 0~1000 F7.31 set range: 0~10000ms In V/F control mode, it is easy to generate current oscillation at certain frequency. In	1	0	○
F7.30	Motor oscillation suppression coefficient	minor cases, the motor can have an unstable operation, in serious cases, it will cause the drive overcurrent. The oscillation suppression function is used to suppress the natural oscillations generated when the drive cooperates with the motor.	1	Model determination	○
F7.31	Motor oscillation suppression filter time	If the output current changes repeatedly during the constant load operation, by properly adjusting the oscillation suppression parameters, based on the factory parameters, F7.29=0 Suppress oscillations by adjusting output frequency; F7.29=1 Suppress oscillations by adjusting output voltage.	1ms	100ms	○
Group F8: PID control parameters					
F8.00	PID operation control selection	0: Disable (Ready mode) 1: Enable (Ready mode)	1	0	×
F8.01	Target value channel selection	When the frequency input channel is selected to 8, the drive operation mode is process PID control. 0: F8.05 digital input; 1: All;	1	0	×

Parameter Code	Parameter name	Parameter detailed description	Minimum Unit	Factory value	Change
		2: AI2; 3: Reserved 4: PULSE setting; 5: Communication setting 6: Multistage instruction setting 7: Keypad digital potentiometer input 8: Reserved This function code determines the target input channel of PID. The set target of PID is a relative value, and the set 100% corresponds to 100% of the feedback signal of the controlled system. The system always performs calculation based on relative value (0 to 100.0%).			
F8.02	Feedback channel selection	This function code is used to select the PID feedback channel. 0: AI1; 1: AI2; 2: Reserved 3: Pulse 4: Communication setting Note: The target input channel and the feedback channel cannot be the same, otherwise, the PID cannot be controlled effectively.	1	0	×
F8.03	Target value channel selection	Set range: 0~1000ms The external target input signal and feedback signal often overlap a certain interference. The channel is filtered by setting the filter time. The longer the filter time, the stronger the anti-interference ability, but the response becomes slower;	1ms	10ms	○
F8.04	Feedback channel filter	the faster the filter time, the faster the response, but the anti-interference ability weakens.	1ms	10ms	○
F8.05	Target value digital setting	Universal drive mode setting range: 0.0~100.0% Water supply drive mode setting range: 0.0~F8.23	0.1% Or 0.1bar	0.0% Or 0.0bar	○
F8.06	Proportional gain Kp1	Set range: 0~1000 Determine the adjustment intensity of the entire PID. The larger the proportional gain, the stronger the adjustment intensity. When there is a deviation between the feedback and target value, the output and the deviation are adjusted in proportion. If the deviation is constant, the adjustment amount is also constant. Proportional adjustment can quickly respond to	1	10	○

Parameter Code	Parameter name	Parameter detailed description	Minimum Unit	Factory value	Change
		<p>changes in feedback, but just proportional adjustment cannot achieve non-differential control. The larger the proportional gain, the faster the adjustment speed of the system, but if it is too large, oscillations will occur.</p> <p>The adjustment method is to first set the integration time to be very long and the differential time to zero. Use only proportional adjustment to make the system run, change the target value, and observe the stable deviation (static difference) between the feedback signal and the target value. If the static difference is in the direction of target value changes (for example, increasing the input quantity, the feedback quantity is always less than the target value after the system is stable), continue to increase the proportional gain, otherwise decrease the proportional gain, and repeat the above process until the static difference is relatively small.</p>			
F8.07	Integration time T_{i1}	<p>Set range: 1~10000ms</p> <p>Determine how fast the PID regulator performs integral adjustment on the deviation between the PID feedback and the target value. The shorter the integration time, the greater the adjustment intensity.</p> <p>When there is a deviation between the feedback and the target value, the output adjustment accumulates continuously. If the deviation persists, increase the adjustment constantly, until there is no deviation. The integral regulator can effectively eliminate static difference. If the integral regulator is too strong, there will be repeated overshoot, making the system unstable until oscillation occurs.</p> <p>The characteristics of the oscillation caused by excessive integration are as follows: The feedback signal swings up and down at an input quantity, and the swing gradually increases until it oscillates.</p> <p>The adjustment of the integration time parameter is generally from large to small, gradually adjust the integration time, and observe the effect of the system</p>	1ms	500ms	○

Parameter Code	Parameter name	Parameter detailed description	Minimum Unit	Factory value	Change
		adjustment until the stable speed of the system reaches the requirements.			
F8.08	Differential time Td1	Set range: 0~10000ms Determine how strong the PID regulator performs adjustment on the deviation change rate between the PID feedback quantity and the target value. The shorter the differential time, the greater the adjustment intensity. When the deviation between feedback and target value changes, an adjustment proportional to the deviation change rate is output. The adjustment is only related to the direction and magnitude of the deviation change, and has nothing to do with the direction and magnitude of the deviation itself. The function of differential adjustment is to adjust according to the changing trend when the feedback signal changes, thus to suppress the change of the feedback signal. Please use the differential regulator with caution, because the differential regulation is easy to amplify the interference of the system, especially the interference with a higher change frequency.	1ms	0ms	○
F8.09	Proportional gain Kp2	F8.09 set range: 0~1000 F8.10 set range: 1~10000ms F8.11 set range: 0~10000ms	1	5	○
F8.10	Integration time Ti2	The parameter functions are the same as F8.06~F8.08, when used to switch the two groups of PID parameters. Please refer to F8.12 for switching between both PID parameters.	1ms	2000ms	○
F8.11	Differential time Td2		1ms	0ms	○
F8.12	Gain switching conditions	0: Do not switch 1: Switch through the DI terminal: The function of the DI terminal is set to 21 (PID parameter switch). When the terminal is invalid, select parameter group 1 (F8.06~F8.08). When the terminal is valid, select parameter group 2 (F8.09~F8.11). 2: Automatic switch based on the deviation: Select the parameter group 1 (F8.06~F8.08) when the absolute value of the deviation between the target value and the feedback quantity is less than the	1	0	○

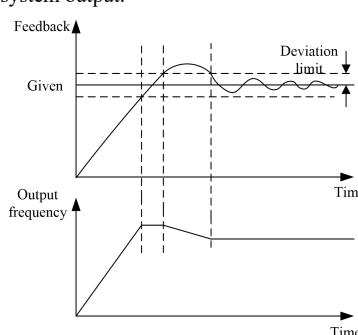
Parameter Code	Parameter name	Parameter detailed description	Minimum Unit	Factory value	Change
		switch threshold (F8.13), and select the parameter group 2 (F8.09 ~ F8.11) when greater than the switch threshold (F8.13) . 3: Switch automatically according to PID output: When the PID output (0~ maximum output frequency corresponds to 0.0~100.0%) is less than the switch threshold (F8.13), select parameter group 1 (F8.06~F8.08), and select parameter group 2 (F8.09~F8.11) when greater than the switch threshold (F8.13)			
F8.13	Gain switching threshold	Set range: 0.0~100.0% The PID parameter switch threshold is valid when the gain switch condition (F8.12) is set to 2 or 3.	0.1%	0.0%	○
F8.14	PID sampling period	Set range: 1~60000ms The sampling period T is a sampling period of the feedback quantity, and the PID regulator operates once in each sampling period. The greater the sampling period, the slower the response.	1ms	1ms	○
F8.15	Deviation limit	Set range: 0.0~50.0% The deviation limit corresponds to a closed-loop input value. When the absolute value of the deviation between the target value and the feedback quantity is within this range, the PID stops adjusting, as shown in the figure. The proper setting of this function helps to consider the accuracy and stability of the system output. 	0.1%	0.0%	○
F8.16	Closed-loop regulation features	0: Positive action. When the feedback signal is less than the input quantity, the output frequency of the drive rises to make the PID reach balance. Such as	1	0	○

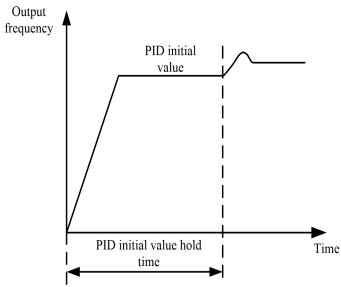
Parameter Code	Parameter name	Parameter detailed description	Minimum Unit	Factory value	Change
		rewinding tension PID control. 1: Negative action. When the feedback signal is less than the input quantity, the output frequency of the drive drops to make the PID reach balance. Such as unwinding tension PID control.			
F8.17	PID initial value	F8.17 set range: 0.0~100.0% F8.18 set range: 0.00~600.00s 1. After the drive starts, accelerate to the initial PID value (F8.17) according to the acceleration time. After running for a period of time at this initial value (F8.18), the PID starts the closed-loop adjustment operation. 2. This function allows the closed-loop adjustment to quickly enter the stable phase.	0.1%	0.0%	×
F8.18	PID initial value hold time		0.01s	0.00s	×
F8.19	Closed-loop output polarity selection	0: Closed-loop output is negative, run at zero-frequency 1: Closed-loop output is negative, reverse	1	0	○
F8.20	PID reverse cutoff frequency	Set range: 0.00~upper limit frequency When the PID output frequency is negative (i.e. the drive reverses), determine the upper limit of the reverse frequency.	0.01Hz	2.00Hz	×
F8.21	PID feedback loss detection value	F8.21 set range: 0.0~100.0% F8.22 set range: 0.0~200.0s (0.0s indicates no detection) When the feedback value is less than the feedback loss detection value and the feedback loss detection time has passed, the drive reports a closed-loop feedback loss fault (E020).	0.1%	10.0%	○
F8.22	PID feedback loss detection time		0.1s	0.0s	○
F8.23	Maximum sensor range	Set range: 0.0~200.0bar The maximum range of the sensor corresponds to the maximum value of the	0.1bar	10.0bar	○

Parameter Code	Parameter name	Parameter detailed description	Minimum Unit	Factory value	Change
		closed-loop input value.			
F8.24	Water supply sleep selection	0: Automatic sleep 1: Run at lower limit frequency	1	0	○
F8.25	Water supply sleep detection time	F8.25 set range: 0.0~3600.0s F8.26 set range: 0.01~600.00s Sleep detection pressure = (100.0%-F8.15) * set pressure value. When the drive is running, it will detect	0.1s	2.0s	○
F8.26	Water supply sleep deceleration time	whether the feedback pressure is higher than the sleep detection pressure. If the feedback pressure is higher than the sleep detection pressure, the drive starts the sleep detection. After the water supply sleep detection delay time set by F8.25, if the feedback pressure is still greater than the sleep detection pressure, it enters the sleep status, and the drive gradually reduces the output frequency according to the water supply sleep deceleration time defined by F8.26. If the feedback pressure becomes lower than the sleep detection pressure in the above process, the drive determines that the sleep detection has failed, and the drive returns to the PID adjustment status.	0.01s	30.00s	○
F8.27	Water supply wake pressure tolerance	F8.27 set range: 0.0~100.0% (100.0% is the set pressure value) F8.28 set range: 0.0~3600.0s 1. Water supply wake-up pressure = (100.0%-F8.27) * set pressure value. 2. When the drive enters the sleep status, if the feedback pressure is lower than the	0.1%	10.0%	○
F8.28	Water supply wake detection time	water supply wake-up pressure, the drive starts wake-up detection. After the water supply wake-up detection time set by F8.28, if the feedback pressure is still lower than the wake-up pressure, the wake-up is successful and the drive returns to the PID adjustment status, otherwise the wake-up fails. Setting the wake-up pressure too high may cause the drive to start and stop frequently. Setting it too low may cause insufficient water	0.1s	2.0s	○

Parameter Code	Parameter name	Parameter detailed description	Minimum Unit	Factory value	Change
		supply pressure.			
F8.29	Water pressure overpressure alarm detection value	Set range: 0.0~100.0% (Do not test when set to 0, 100.0% is the maximum range of pressure sensor) When the feedback pressure is greater than or equal to this set value, and after the F8.31 pressure abnormal alarm detection time, a water pipe overpressure indication is output (the terminal outputs No. 24 function).	0.1%	90.0%	○
F8.30	Water pressure undervoltage alarm detection value	Set range: 0.0~100.0% (Do not test when set to 0, 100.0% is the maximum range of pressure sensor) When the feedback pressure is less than or equal to this set value, and after the F8.31 pressure abnormal alarm detection time, a water pipe under-pressure indication is output (the terminal outputs No. 25 function).	0.1%	0.0%	○
F8.31	Water pressure abnormal alarm detection time	Set range: 0.0~3600.0s	0.1s	50.0s	○
F8.32	Water shortage alarm set value	F8.32 set range: 0.0~100.0% (100.0% is the set pressure value) F8.33 set range: 0.0~3600.0s F8.34 set range: 0~10000min (0min	0.1%	0.0%	○
F8.33	Water shortage alarm detection time	indicate there's no water shortage restart function) When the output frequency reaches the upper limit, the feedback pressure is still less than or equal to F8.32 water shortage set value and after F8.33 water shortage alarm detection time, a water pipe water shortage indication (the terminal outputs No. 26 function) will be output and the E023 water shortage fault will be reported.	0.1s	20.0s	○
F8.34	Water shortage restart wait time	When the E023 water shortage fault occurs, without resetting the fault manually, it will automatically reset and restart the operation after the F8.34 water shortage restart wait time.	1min	0min	○

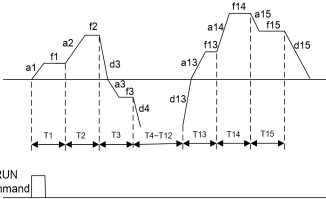
Parameter Code	Parameter name	Parameter detailed description	Minimum Unit	Factory value	Change
F8.35	Water supply absolute sleep detection time	Setting range: 0~3600.0s When the drive sleeps and decelerates to the lower limit frequency, it will run at the lower limit frequency for the time defined by F8.35 and then go to zero frequency operation.	0.1s	10.0s	○
F8.36	Delay time of pump reduction in shutdown	Set range: 2~240s This function code is used as the delay time between successive shutdown of water pumps in power frequency operation when manual shutdown is carried out in automatic control mode.	1s	2s	○
F8.37	Add and reduce pump delay time	Set range: 1~36s The function code is used to judge the delay time before adding and reducing the pump.	1s	5s	○
F8.38	Add pump action frequency	Set range: Lower limit frequency~Upper limit frequency When the drive is in the running condition, the pump frequency value \geq F8.38 set value, and after F8.37 delay time, the number of pumps will be increased.	0.01Hz	50.00Hz	×
F8.39	Reduce pump operation frequency	Set range: Lower limit frequency~Upper limit frequency When the drive is in the running condition, the pump frequency value \leq F8.39 set value, and after F8.37 delay time, the number of pumps will be reduced.	0.01Hz	15.00Hz	×
Group F9: Multistage speed control parameters					
F9.00	Simple PLC run mode selection	<p>LED single digit: PLC run mode</p> <p>0: No action</p> <p>1: Stop after a single cycle: The drive will stop automatically after completing one cycle. You need to give a run command again to start.</p>  <p>2: Keep the final value after a single cycle: The drive will automatically keep the operation frequency and direction of the last stage after completing one cycle.</p>	1111	0004	×

Parameter Code	Parameter name	Parameter detailed description	Minimum Unit	Factory value	Change
		<div data-bbox="354 172 693 343"> </div> <p data-bbox="325 387 667 483">3: Continuous cycle: The drive will automatically start the next cycle after completing one cycle, till there's a stop command.</p> <div data-bbox="325 491 693 678"> </div> <p data-bbox="325 715 689 885">4: DI selection operation: Determine the current operation stage by selecting the ON/OFF combination of input terminal functions 12~15. For the combination method, please refer to No. 12~15 function description of group F6 multifunctional input terminals. LED tens digit: Start mode</p> <p data-bbox="325 911 674 1007">0: Restart from the first stage: Stop during operation (caused by stop command, fault or power failure), and start from the first stage after restart.</p> <p data-bbox="325 1010 689 1230">1: Continue operation from the stage of interruption: Stop during operation (caused by stop command or fault), the drive automatically records the run time of the current stage, and automatically enters this stage after restarting, and continues the operation in the remaining time at the frequency defined by this stage.</p> <div data-bbox="328 1233 693 1433"> </div>			

Parameter Code	Parameter name	Parameter detailed description	Minimum Unit	Factory value	Change
		LED hundreds digit: Stage time unit selection 0: Second 1: Minute LED thousands digit: Store at power failure 0: Do not store at power failure 1: Stage at power failure storage interruption			
F9.01	Running stages	Set range: 1~16 Number of stages in a single PLC cycle.	1	16	○
F9.02	Multistage instruction 1	Lower limit frequency ~ upper limit frequency	0.01Hz	20.00Hz	○
F9.03	Stage 1 instruction setting	LED single digit: 0: Multistage instruction 1 (F9.02) 1: AI1 2: AI2 3: Pulse frequency 4: Communication 5: Keypad digital potentiometer input 6: Reserved LED tens digit: 0: Acceleration/deceleration time 1 1: Acceleration/deceleration time 2 2: Acceleration/deceleration time 3 3: Acceleration/deceleration time 4 LED hundreds digit: 0: Forward running 1: Reverse running Note: Only the LED single digit frequency source of stage 1 instruction can be set.	111	005	○
F9.04	Stage 1 instruction running time	Set range: 0.1~6000.0 Note: For the time unit selection, see F9.00 hundreds digit setting.	0.1	10.0	○
F9.05	Multistage instruction 2	Stage X instruction (F9.05, F9.08, F9.11, F9.14, F9.17, F9.20, F9.23, F9.26, F9.29, F9.32, F9.35、 F9.38, F9.41, F9.44, and F9.47) setting range:	0.01Hz	20.00Hz	○
F9.06	Stage 2 instruction setting	Lower limit frequency ~ upper limit frequency	111	000	○
F9.07	Stage 2 instruction running time	Stage X instruction (F9.06, F9.09, F9.12, F9.15, F9.18, F9.21, F9.24, F9.27, F9.30, F9.33, F9.36、 F9.39, F9.42, F9.45, and F9.48) setting range:	0.1	10.0	○
F9.08	Multistage	LED single digit:	0.01Hz	20.00Hz	○

Parameter Code	Parameter name	Parameter detailed description	Minimum Unit	Factory value	Change
	instruction 3	0: Multistage instruction x 1: Reserved			
F9.09	Stage 3 instruction setting	LED tens digit: 0: Acceleration/deceleration time 1 1: Acceleration/deceleration time 2 2: Acceleration/deceleration time 3 3: Acceleration/deceleration time 4	111	000	○
F9.10	Stage 3 instruction running time	LED hundreds digit: 0: Forward running 1: Reverse running	0.1	10.0	○
F9.11	Multistage instruction 4	Stage X instruction running time (F9.07, F9.10, F9.13, F9.16, F9.19, F9.22, F9.25, F9.28, F9.31, F9.34, F9.37、F9.40, F9.43, F9.46, and F9.49) setting range:	0.01Hz	20.00Hz	○
F9.12	Stage 4 instruction setting	0.1~6000.0 Note: For the time unit selection, see F9.00 hundreds digit setting.	111	000	○
F9.13	Stage 4 instruction running time		0.1	10.0	○
F9.14	Multistage instruction 5		0.01Hz	20.00Hz	○
F9.15	Stage 5 instruction setting		111	000	○
F9.16	Stage 5 instruction running time		0.1	10.0	○
F9.17	Multistage instruction 6		0.01Hz	20.00Hz	○
F9.18	Stage 6 instruction setting		111	000	○
F9.19	Stage 6 instruction running time		0.1	10.0	○
F9.20	Multistage instruction 7		0.01Hz	20.00Hz	○
F9.21	Stage 7 instruction setting		111	000	○
F9.22	Stage 7 instruction running		0.1	10.0	○

Parameter Code	Parameter name	Parameter detailed description	Minimum Unit	Factory value	Change
	time				
F9.23	Multistage instruction 8		0.01Hz	20.00Hz	○
F9.24	Stage 8 instruction setting		111	000	○
F9.25	Stage 8 instruction running time		0.1	10.0	○
F9.26	Multistage instruction 9		0.01Hz	20.00Hz	○
F9.27	Stage 9 instruction setting		111	000	○
F9.28	Stage 9 instruction running time		0.1	10.0	○
F9.29	Multistage instruction 10		0.01Hz	20.00Hz	○
F9.30	Stage 10 instruction setting		111	000	○
F9.31	Stage 10 instruction running time		0.1	10.0	○
F9.32	Multistage instruction 11		0.01Hz	20.00Hz	○
F9.33	Stage 11 instruction setting		111	000	○
F9.34	Stage 11 instruction running time		0.1	10.0	○
F9.35	Multistage instruction 12		0.01Hz	20.00Hz	○
F9.36	Stage 12 instruction setting		111	000	○
F9.37	Stage 12		0.1	10.0	○

Parameter Code	Parameter name	Parameter detailed description	Minimum Unit	Factory value	Change
	instruction running time				
F9.38	Multistage instruction 13		0.01Hz	20.00Hz	○
F9.39	Stage 13 instruction setting		111	000	○
F9.40	Stage 13 instruction running time		0.1	10.0	○
F9.41	Multistage instruction 14		0.01Hz	20.00Hz	○
F9.42	Stage 14 instruction setting		111	000	○
F9.43	Stage 14 instruction running time		0.1	10.0	○
F9.44	Multistage instruction 15		0.01Hz	20.00Hz	○
F9.45	Stage 15 instruction setting		111	000	○
F9.46	Stage 15 instruction running time		0.1	10.0	○
F9.47	Multistage instruction 16		0.01Hz	20.00Hz	○
F9.48	Stage 16 instruction setting		111	000	○
F9.49	Stage 16 instruction running time		0.1	10.0	○
Group FA: Protection function parameters					
FA.00	DC bus undervoltage	Set range: 50~999V This function code specifies the allowed lower limit voltage of the DC bus when	1V	Model determination	×

Parameter Code	Parameter name	Parameter detailed description	Minimum Unit	Factory value	Change
	protection point	the drive works normally. Note: When the grid voltage is too low, the output torque of the motor will decrease. So, the drive needs to be derated for long-term operation at low grid voltage.			
FA.01	Undervoltage fault action selection	0: During running, the voltage is lower than the undervoltage point, and an undervoltage fault E007 is reported. 1: During running, the voltage is lower than the undervoltage point, and P.off is reported.	1	0	×
FA.02	Motor overload protection action selection	0: No action 1: Action, E008 fault is reported when the motor is overloaded.	1	1	×
FA.03	Reserved	-	-	-	*
FA.04	Reserved	-	-	-	*
FA.05	Input phase loss protection action selection	0: No action 1: Action, E011 fault is reported during input phase loss	1	0	×
FA.06	Output phase loss protection delay time	Set range: 0.0~6000.0S (0.0s indicates no detection for output phase loss)	0.1s	6.0s	×
FA.07	485 communication fault protection action selection	0: No action 1: Action, E016 fault is reported when 485 communication is abnormal.	1	0	×
FA.08	Number of automatic resets	FA.08 set range: 0~100 (0 indicates no automatic reset function) FA.09 set range: 0.1~1000.0s 1. Number of automatic resets: When the drive selects automatic reset for faults, it is used to set the number of automatic resets. When the number of continuous resets exceeds this value, the drive will report a fault and stop and will not reset	1	0	×

Parameter Code	Parameter name	Parameter detailed description	Minimum Unit	Factory value	Change
FA.09	Automatic reset interval time	<p>automatically.</p> <p>2. Fault automatic reset interval time: Select the time interval from the fault occurrence to the automatic reset action.</p> <p>3. Within 2 minutes after the drive operates, if there is no fault, it will automatically clear the number of resets, and accumulate the number of resets from the beginning.</p> <p>4. When the number of automatic resets is set to 0, it indicates that automatic reset is prohibited and fault protection is performed immediately.</p> <p>Note: The drive module protection (E010) and external equipment failure (E015) have no automatic reset function. After the automatic reset is completed, it will automatically start and run at the speed tracking. Use the automatic fault reset function with caution, otherwise, it may cause personal injuries and property losses.</p>	0.1s	5.0s	×
FA.10	Wave-by-wave current limiting points setting	<p>FA.10 set range: 0.0~250.0% (0.0% indicates there is no wave-by-wave current limiting function)</p> <p>FA.11 set range: 0~60000 ms (0 ms indicates no fault alarm function of wave-by-wave current limiting)</p>	0.1%	0.0%	×
FA.11	Wave-by-wave current limiting time	<p>When the output current is greater than the wave-by-wave current limiting point set by FA.10, perform wave-by-wave current limiting, and when the current limiting time exceeds the wave-by-wave current limiting time set by FA.11, report the E029 fault.</p>	1ms	0ms	×
FA.12	Delay time of abnormal protection of buffer circuit	<p>Set range: 0.0~20.0s (0.0s indicates no detection function for abnormal buffer circuit)</p> <p>In the running state, if the buffer circuit is abnormal and exceeds the delay time set by FA.12, report the E026 fault.</p>	0.1s	1.0s	○
FA.13	Reserved	-	-	-	*

Chapter IV Function Parameter Table

Parameter Code	Parameter name	Parameter detailed description	Minimum Unit	Factory value	Change
FA.14	Overload pre-alarm detection setting	LED unit digit: action selection 0: Always check 1: Only check during constant speed LED tenth digit: alarm selection 0: No alarm and continue running 1: Alarm and shutdown LED hundredth digit: Detection reference 0: Relative to motor rated current (E008) 1: Relative to drive's rated current(E009)	111	000	×
FA.15	Overload pre-alarm detection level	Setting range: 20.0~200.0%	0.1%	130.0%	×
FA.16	Overload pre-alarm detection time	Setting range: 0.0~60.0s	0.1s	5.0s	×
Group Fb: Serial communication parameters					
Fb.00	Local address	Set range: 0~247 The local address is unique in the communication network, which is the basis for the point-to-point communication between the host computer and the drive. Note: 0 is the broadcast address	1	1	×
Fb.01	Communication configuration	LED single digit: Baud rate selection 0: 1200BPS 1: 2400BPS 2: 4800BPS 3: 9600BPS 4: 19200BPS 5: 38400BPS LED tens digit: Data format 0: 1-8-2-N format, RTU 1: 1-8-1-E format, RTU 2: 1-8-1-O format, RTU 3: 1-7-2-N format, ASCII 4: 1-7-1-E format, ASCII 5: 1-7-1-O format, ASCII 6: 1-8-1-N format, RTU Note: The baud rate set by the upper computer and the drive must be consistent, otherwise, the communication cannot be carried out. The greater the baud rate, the faster the communication speed.	11	03	×
Fb.02	Reserved	-	-	-	*
Fb.03	Local response	Set range: 0~1000ms The local response delay refers to the	1ms	5ms	×

Parameter Code	Parameter name	Parameter detailed description	Minimum Unit	Factory value	Change
	delay	interval between the end of drive data receiving and the sending of response data to the host computer. If the response delay is less than the system processing time, the response delay is based on the system processing time. If the response delay is greater than the system processing time, after the system has processed the data, it must wait until the response delay time is reached before sending data to the host computer.			
Fb.04	Communication timeout detection time	Set range: 0.0~100.0s If the communication timeout fault time is set to 0, this function is invalid. If the time interval between two communications exceeds the communication timeout fault time, the system reports a communication fault E016, and the communication condition can be monitored. Usually, it is set to invalid. If this parameter is set in a continuous communication system, the communication condition can be monitored.	0.1s	0.0s	×
Fb.05	Master send selection	LED unit digit: Running status of the current master 0: disable 1: enable LED tenth digit: Current running frequency of the master 0: disable 1: enable 1、When the drive is set as the communication master (Fb.00 is set to 0), it can send data to the slave computer. At this point, the master inverter sends a broadcast command, and all slaves receive the command sent by the master. 2、The master can send a maximum of two frames of data in polling mode. If this parameter is set to invalid, the master does not send data. Note: Only RTU communication mode supports master sending.	11	11	×
Fb.06	Network interface enable	0: disable 1: enable	1	0	○
Fb.07	Network protocol	0: Modbus TCP protocol 1: Firmware Upgrade Protocol	1	0	○

Parameter Code	Parameter name	Parameter detailed description	Minimum Unit	Factory value	Change
Fb.08	Reserved	-	-	-	*
Fb.09	The local IP address is 1 segment	Set range: 0~255 Set the local IP address for Ethernet communication. Local IP address format: Fb.09.Fb.10.Fb.11.Fb.12。 For example, the local IP address is 192.168.1.30.	1	192	○
Fb.10	The local IP address is 2 segment		1	168	○
Fb.11	The local IP address is 3 segment		1	1	○
Fb.12	The local IP address is 4 segment		1	30	○
Fb.13	Subnet mask 1 segment		Set range: 0~255	1	255
Fb.14	Subnet mask 2 segment	Set the subnet mask for Ethernet communication. Subnet mask format: Fb.13.Fb.14.Fb.15.Fb.16。 For example, the subnet mask is 255.255.255.0.	1	255	○
Fb.15	Subnet mask 3 segment	Set range: 0~255 Set the gateway for Ethernet communication. The gateway format: Fb.17.Fb.18.Fb.19.Fb.20。 For example, the gateway is 192.168.1.1.	1	255	○
Fb.16	Subnet mask 4 segment		1	0	○
Fb.17	Gateway 1 section		1	192	○
Fb.18	Gateway 2 section		1	168	○
Fb.19	Gateway 3 section	Set range: 0~255 Set the gateway for Ethernet communication. The gateway format: Fb.17.Fb.18.Fb.19.Fb.20。 For example, the gateway is 192.168.1.1.	1	1	○
Fb.20	Gateway 4 section		1	1	○
Group FC: Auxiliary function parameters					
FC.00	Energy consumption braking threshold	FC.00 set range: 350~800V FC.01 set range: 0~100% 1. Energy consumption braking function. If the drive bus voltage is higher than the energy consumption braking threshold, the built-in braking unit will act. In this case, if a braking resistor is connected, the pumping voltage energy at the drive internal current side will be released	1V	Model determination	×
FC.01	Energy consumption braking duty cycle		1%	50%	×

Parameter Code	Parameter name	Parameter detailed description	Minimum Unit	Factory value	Change
		<p>through the braking resistor to make the bus voltage drop.</p> <p>2. The energy consumption braking duty cycle is used to adjust the duty cycle of the braking unit. If the braking utilization rate is high, the braking unit action duty cycle is high and the braking effect is strong, but the drive bus voltage fluctuates greatly during the braking process.</p> <p>Note: The setting of this function shall consider the resistance and power of the braking resistor. Be sure to set the function parameters correctly according to the actual use.</p>			
FC.02	AVR function	<p>0: No action 1: Act always 2: Do not act only during deceleration</p> <p>When the input voltage deviates from the rated value, this function can keep the output voltage constant, so generally the AVR shall operate, especially when the input voltage is higher than the rated value.</p> <p>Note: When decelerating and stopping, the AVR does not act, the deceleration time is short, but the running current is slightly larger; when the AVR acts all the time, the motor decelerates smoothly and the running current is small, but the deceleration time becomes longer.</p>	1	2	×
FC.03	Automatic energy-saving operation	<p>0: No action 1: Action</p> <p>During the no-load or light-load operation, the motor detects the load current and adjusts the output voltage appropriately to achieve the purpose of energy saving.</p>	1	0	○
FC.04	Slip compensation gain	<p>FC.04 set range: 0~1000 (0 indicates no compensation)</p> <p>FC.05 set range: 0.1~20.0ms</p> <p>1. The change of the motor load torque will affect the motor slip and cause the motor speed to change. Through slip</p>	1	0	○

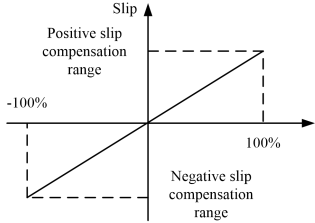
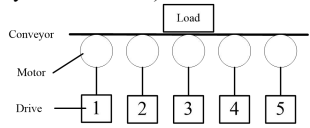
Parameter Code	Parameter name	Parameter detailed description	Minimum Unit	Factory value	Change
FC.05	Slip compensation filter time	<p>compensation, the output frequency of the drive is automatically adjusted according to the load torque of the motor, which can reduce the speed change of the motor caused by load changes, as shown in the figure.</p>  <p>2. Electric status: When the actual speed is lower than the input speed, gradually increase the compensation gain (FC.04).</p> <p>3. Generation status: When the actual speed is higher than the input speed, gradually increase the compensation gain (FC.04).</p> <p>4. The filter time constant of slip compensation. The shorter the filter time, the faster the response, but too short will easily cause oscillation and speed instability.</p>	0.1ms	10.0ms	○
FC.06	Cooling fan control	<p>0: Run in automatic mode Note: The fan is turned off at least 3 minutes after stop and when the temperature is lower than 40 degrees. 1: The fan keeps rotating during power-on</p>	1	0	×
FC.07	Acceleration/deceleration time unit	<p>0: Second 1: Minute</p>	1	0	×
FC.08	Droop control frequency	<p>Set range: 0.00~10.00Hz</p> <p>1. The droop control is suitable for the occasions where multiple drives drive the same load. By setting this function, multiple drives can reach a uniform distribution of power when driving the same load. Transmission gears are shown in the following figure (5 drives drive the conveyors of 5 motors)</p> 	0.01Hz	0.00Hz	○

Parameter Code	Parameter name	Parameter detailed description	Minimum Unit	Factory value	Change
		<p>2. When the load of a certain drive is heavy, the drive will automatically reduce the output frequency appropriately according to the parameters set by this function to unload part of the load. This value can be adjusted gradually from small to large during debugging. The relationship between load and output frequency is shown in the following figure:</p>			
FC.09	Deceleration factor	<p>Set range: 50.0%~180.0%</p> <p>For the coefficient of voltage-frequency ratio during deceleration, increase the voltage-frequency ratio during deceleration, in this case, the output voltage increases and the deceleration will be faster, which is good for quick stop without reporting overvoltage.</p>	0	100.0%	○
FC.10	Zero frequency arrival range	<p>Set range: 0.00~10.00Hz</p> <p>When the output frequency is less than or equal to the set value of this function code, an indication signal is output (the terminal outputs No. 10 function).</p>	0.01Hz	0.00Hz	○
FC.11	Set length	<p>FC.11 set range: 0~65535m (0 indicates the fixed-length stop function is invalid)</p> <p>FC.12 set range: 0.001~10.000m</p> <p>FC.13 set range: 1~9999</p> <p>1. This group of functions is used to realize the fixed-length stop function.</p>	1m	0m	○
FC.12	Measuring shaft circumference	<p>2. The drive inputs counting pulses from DI5 (F6.19 needs to be set to 1), and obtains the actual length according to the number of pulses per revolution of the speed measuring shaft (FC.13) and the shaft circumference (FC.12).</p> <p>3. Actual length = Number of counting</p>	0.001m	0.100m	○

Parameter Code	Parameter name	Parameter detailed description	Minimum Unit	Factory value	Change
FC.13	Pulse per revolution	pulses/number of pulses per revolution \times circumference of the measuring shaft. 4. When the actual length (U0.15) \geq the set length (FC.11), the drive will automatically send a stop command to stop. You need to clear the actual length before running again, otherwise it will not start. Note: The multifunctional input terminal can be used to clear the actual length (Dlx is defined to No. 24 function), the normal counting and the actual length calculation can be performed only after the terminal is disconnected. The actual length is U0.15, and it is automatically stored during power failure.	1	1	○
FC.14	Dead zone compensation coefficient	Set range: 0~20	1	Model determination	×
FC.15	STOP key stop function selection	0: Only valid for keypad control 1: Valid for all control modes (invalid in two-wire control mode)	1	0	○
FC.16	Digital potentiometer power failure save selection	0: The digital potentiometer frequency is not saved during power failure, and will start from 0.00Hz after power-on. 1: The digital potentiometer frequency is saved during power failure, and will start from the power failure frequency after power-on.	1	1	○
FC.17	The first shortcut parameter display selection	Set range: 0~31 When set to 0~28, it corresponds to group U0 parameter number; when set to 29, it displays the operation frequency during fixed operation, and displays the instruction frequency during standby; when set to 4, it displays the operation speed during fixed operation, and displays the instruction speed during standby; when set to 5, it displays the operating linear speed during fixed operation, and displays the instruction linear speed during standby.	1	31	○
FC.18	Speed display factor	Set range: 0.01~100.00 This function code is used to correct the display error of the rotation speed and has no effect on the actual rotation speed. Note: Speed =	0.01	1.00	○

Parameter Code	Parameter name	Parameter detailed description	Minimum Unit	Factory value	Change
		120*frequency*FC.18/number of motor poles (F3.11)			
FC.19	Linear speed display factor	Set range: 0.01~100.00 This function code is used to correct the display error of the linear speed and has no effect on the actual linear speed. Note: Linear speed = speed*FC.19	0.01	1.00	○
FC.20	Frequency linkage selection	0: No linkage ratio 1: FC.21 is the coefficient linkage instruction frequency and acceleration/deceleration 1 2: FC.21 is used as the factor linkage instruction frequency 3: All voltage value is the coefficient linkage instruction frequency and acceleration/deceleration 1 4: All voltage value is used as the factor linkage instruction frequency	1	0	○
FC.21	Linkage ratio factor	Set range: 0.000~10.000	0.001	1.000	○
FC.22	Terminal jog priority	0: disable 1: enable Set whether the terminal jog function has the highest priority when the “Run command channel” is set to terminal. When FC.22 is set to 1, the DI multi-function input terminal function 4 (forward jog) or 5 (reverse jog) is valid in normal operation, and it can enter the jog operation state immediately.	1	0	○
FC.23	Zero frequency threshold (acting on the entire frequency range)	Setting range: 0.00~650.00Hz When the set frequency is less than or equal to the set value of this function code, it will run at zero frequency.	0.01Hz	0.00Hz	○
FC.24	Display selection	LED unit digit: quick parameter display selection 0: Display 6 shortcut parameters (Refer to Chapter 3 Operation Instructions for details) 1: Display 1 shortcut parameter, determined by function code FC.17 LED tenth digit: U group display selection 0: Display U group 1: Do not display U group	11	00	○
Group Fd: Virtual terminal parameter function					
Fd.00	VDI1	Same as F6.00~F6.08 function code	1	0	×

Parameter Code	Parameter name	Parameter detailed description	Minimum Unit	Factory value	Change
	terminal function selection	setting.			
Fd.01	VDI2 terminal function selection	Note: The VDI virtual terminal is an extension of the physical input terminal. The communication sends instructions to simulate the actual terminal. Each bit in the communication data represents a terminal, and the value of each bit represents the status of the corresponding terminal. For specific bit definition, please refer to the communication address 0x1206 description. The function of each terminal cannot be the same. If the functions of the two terminals are set to the same, the physical terminal will act prior to the virtual terminal in order, the DI ports ranked first will work first, and the latter ones will not work.	1	0	×
Fd.02	VDI3 terminal function selection		1	0	×
Fd.03	VDI4 terminal function selection		1	0	×
Fd.04	VDI5 terminal function selection		1	0	×
Fd.05	VDI6 terminal function selection		1	0	×
Fd.06	VDI7 terminal function selection		1	0	×
Fd.07	VDI8 terminal function selection		1	0	×
Fd.08	VDI9 terminal function selection		1	0	×
Fd.09	VDI10 terminal function selection		1	0	×
Fd.10	VDO1 terminal function selection		Same as F6.11~F6.13 function code setting. Note: The VDO virtual terminal is an extension of the physical output terminal. The virtual terminal status can be read only through communication. Each bit in the communication data represents a	1	0
Fd.11	VDO2 terminal function selection	1		0	×

Parameter Code	Parameter name	Parameter detailed description	Minimum Unit	Factory value	Change
Fd.12	VDO3 terminal function selection	terminal, and the value of each bit represents the status of the corresponding terminal. For specific bit definition, please refer to the communication address 0x1207 description.	1	0	×
Fd.13	VDO4 terminal function selection		1	0	×
Fd.14	VDO5 terminal function selection		1	0	×
Fd.15	VDO1 output on delay	Same as F6.29~F6.34 function code setting.	0.1s	0.0s	○
Fd.16	VDO2 output on delay		0.1s	0.0s	○
Fd.17	VDO3 output on delay		0.1s	0.0s	○
Fd.18	VDO4 output on delay		0.1s	0.0s	○
Fd.19	VDO5 output on delay		0.1s	0.0s	○
FE group: Water pump protection function 1					
FE.00	Dry run detection current	FE.00 setting range: 0.0~100.0% motor rated current FE.01 setting range: 0.0~300.0s dry run detection time	0.1%	50.0%	×
FE.01	Dry run detection time	When FE.00 = 0.0, dry run detection is not performed When the drive's running current is less than the dry run detection current, and the running frequency reaches the upper limit frequency. Drive waits for the dry run detection time and displays E032 dry run alarm if the above condition persists.	0.1s	0.0	×
FE.02	Motor stall protection time	FE.02 setting range: 0.0~6000.0s FE.03 setting range: lower limit frequency ~ upper limit frequency	0.1s	0.0s	×
FE.03	Motor stall detection frequency	FE.03 setting range: 0.0~100.0% drive's rated current When the motor stall protection time is 0, the motor stall detection is disabled.	0.01Hz	10.00hz	×
FE.04	Motor stall current	When the operating frequency is less than the motor stall detection frequency and	0.1%	50.0%	×

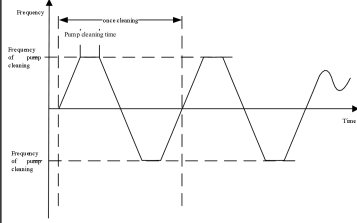
Parameter Code	Parameter name	Parameter detailed description	Minimum Unit	Factory value	Change
		the operating current is greater than the motor stall current then after the motor stall time the drive displays E018 alarm.			
FE.05	Acceleration and deceleration frequency switching point	Setting range: lower limit frequency ~ upper limit frequency When the running frequency is greater than FE.05, use F2.14 and F2.15 for acceleration and deceleration. When it is less than FE.05, use F1.11 and F1.12 for acceleration and deceleration.	0.01Hz	50.00Hz	×
FE.06	Pump cleaning repetitions	FE.06 setting range: 0~100 FE.07 setting range: lower limit frequency ~ upper limit frequency	1	0	×
FE.07	Pump cleaning frequency	FE.08 setting range: 0.0~6000.0s When the FE.06 is 0, the water pump cleaning is disabled. FE.07 Set the operational frequency for pump cleaning. A wave crest runs at FE.07 for FE.08 seconds	0.01Hz	10.00Hz	×
FE.08	Pump cleaning time		0.1s	6.0s	×
FE.09	Frost Protection / Defrost function	Setting range: 00~11 LED unit digit: Frost protection 0: disable 1: enable LED ten digits: Defrost function 0: disable 1: enable	1	0	×
FE.10	Defrost operating frequency	FE.10 Setting range: lower limit frequency ~ upper limit frequency	0.01Hz	8.00Hz	×
FE.11	Defrost running time	FE.11 setting range: 0.0~6000.0s FE.12 setting range: 0.0~6000.0s Every FE.12 seconds, run at FE.10 frequency for FE.11 seconds.	0.1s	60.0s	×
FE.12	Defrost operation interval		0.1s	300.0s	×
FE.13	Defrost braking	FE.13 Setting range: 0.0~100.0% drive's rated current	0.1%	100.0%	×

Parameter Code	Parameter name	Parameter detailed description	Minimum Unit	Factory value	Change
	current	FE.14 setting range: 0.0~6000.0s			
FE.14	Defrost running time	FE.15 setting range: 0.0~6000.0s Every FE.15 seconds, apply DC braking current FE.13 for FE.14 seconds.	0.1s	60.0s	×
FE.15	Deicing operation interval		0.1s	300.0s	○
FE.16	Signal source of water shortage	Setting range: 0~3 0: Use F8.32 function code. 1: Use terminal input When the multi-function DI terminal is set to 35, then this terminal is used to detect water shortage signal. 2: AI1 (0.00~10.00V) 3: AI2 (0.00~10.00V)	0	0	○
FE.17	Water tank shortage threshold	Setting range: 0.0~100.0% (100% means 10V) If FE.16 is set to Ai1 or AI2, it detects the lack of water in the water tank by using this threshold. If the feedback is less than the threshold, the drive will protect and stop and display E023. Further, all industrial frequency pumps (auxiliary pumps) will stop working.	0.1%	10.0%	○
FE.18	Water pipe leakage threshold	FE.18 setting range: 0.0~30.0% set pressure value. FE.19 setting range: 0.0~6000.0s	0.1%	10.0%	○
FE.19	Water pipe leakage detection time	When FE.19 is 0, water pipe leakage detection is disabled. When the pressure feedback value is less than the water pipe leakage threshold (FE.18), and the operating frequency is greater than or equal to the upper limit frequency, a fault will be reported after the detection time (FE.19), "E034" will be displayed and the machine will stop freely.	0.1s	0.0s	○
FF group: Water pump protection function 2					
FF.00	Flow rate	Setting range: 0.0~5000.0 The flow rate Qn of the pump at rated frequency and rated head. Unit: cubic meter/hour	0.1	10.0	×

4.2 Monitoring parameter group U0

Parameter Code	Parameter name	Parameter detailed description
----------------	----------------	--------------------------------

Parameter Code	Parameter name	Parameter detailed description
U0.00	Output frequency	Displays the output frequency of the current drive
U0.01	Set frequency	Displays the set frequency of the current drive
U0.02	Output current	Displays the output current of the current drive
U0.03	Bus voltage	Displays the bus voltage of the current drive
U0.04	Running speed	Displays the running speed of the current drive Note: Speed = 120*frequency*speed display factor (FC.18)/number of motor poles (F3.11)
U0.05	Linear running speed	Displays the linear running speed of the current drive Note: Linear speed = speed*linear speed display factor (FC.19)
U0.06	Output power	Displays the output power of the current drive
U0.07	Output torque	Displays the output torque of the current drive
U0.08	Output voltage	Displays the output voltage of the current drive
U0.09	AI1	Displays the actual input voltage/current of AI1 of the current drive (when the input is of current type, 1mA current corresponds to 0.5V voltage display)
U0.10	AI2	Displays the actual input voltage of AI2 of the current drive (when the input is of current type, 1mA current corresponds to 0.5V voltage display)
U0.11	PID setting	Displays the PID set value of the current drive
U0.12	PID feedback	Displays the PID feedback value of the current drive
U0.13	Counter value	Displays the counter value of the current drive
U0.14	Closed-loop pressure display	Displays the closed-loop pressure value of the current drive Note: Closed-loop pressure = PID feedback value*pressure sensor range (F8.23)
U0.15	Actual length	Displays the actual length accumulated by the fixed length control function of the current drive
U0.16	High-frequency pulse count value	Displays the accumulated pulse count value of the DI5 high-speed input signal of the current drive (not saved after power failure)
U0.17	Pulse frequency display	Displays the pulse frequency of the DI5 high-speed input signal of the current drive
U0.18	Drive rated power	Displays the rated power of the drive
U0.19	Drive rated voltage	Displays the rated voltage of the drive
U0.20	Drive rated current	Displays the rated current of the drive

Parameter Code	Parameter name	Parameter detailed description
U0.21	Pump status description	Set range: 0000~1111 LED unit digit: Pump A status display LED ten digit: Pump B status display LED hundred digit: Pump C status display LED thousand digit: reserved LED ten-thousand digit: reserved 0: Non automatic control mode 1: automatic control mode
U0.22	IGBT temperature	Displays the IGBT temperature of the current drive
U0.23	DI terminal status 1	Displays current input terminal function status (defined by bit, 0 indicates that the current terminal input function is invalid, and 1 indicates that the current terminal input function is valid): LED single digit: DI1 input status LED tens digit: DI2 input status LED hundreds digit: DI3 input status LED thousands digit: DI4 input status LED ten thousands digit: DI5 input status
U0.24	DI terminal status 2	Displays the digital input terminal status (defined by bit, 0 means the terminal status is invalid, 1 means the current terminal input function is valid) LED unit digit: DI6 input status (expansion card) LED tenth digits: DI7 input status (expansion card) LED hundredth digit: DI8 input status (expansion card) LED thousandth digit: reserved LED ten thousandth digit: reserved
U0.25	DO terminal status	Displays current output terminal function status (defined by bit, 0 indicates that the current terminal output function is invalid, and 1 indicates that the current terminal output function is valid): LED single digit: DO1 output status LED tens digit: DO2 output status LED hundreds digit: Relay output status LED thousands digit: Reserved LED 10 thousands digit: Reserved
U0.26	Output frequency (after compensation)	Displays the current output frequency of the drive (after compensation)
U0.27	Running time accumulation	Displays the accumulated running time of the current drive
U0.28	Software version number	Displays the software version number of the current drive
U0.29	Energy consumption	Displays the current accumulative power consumption of the drive

Parameter Code	Parameter name	Parameter detailed description
U0.30	Current flow	Displays the current drives flow $Q = Q_n * f / f_n$ (Q: current flow; Q_n rated flow; f: current operating frequency; f_n : rated frequency)

4.3 Fault record parameter group U1

Parameter Code	Parameter name	Parameter detailed description	Factory value	Change
U1.00	Historical fault number	Set range: 0~9 According to the setting of this function code, you can view the fault record information of the last 10 times. By setting different values within U1.01~U1.06, the corresponding fault record will display.	0	○
U1.01	Fault code during fault	Fault record information at the xth fault (x is the set value of U1.00)	-	*
U1.02	Bus voltage during fault		-	*
U1.03	Output current during fault		-	*
U1.04	Running frequency during fault		-	*
U1.05	Running temperature during fault		-	*
U1.06	Fault occurrence time		-	*

4.4 Fault code summary table

Fault code	Fault type	Fault code	Fault type
E001	Drive accelerated running overcurrent	E016	485 communication error alarm
E002	Drive decelerated running overcurrent	E017	Current detection circuit fault alarm
E003	Drive constant-speed running overcurrent	E018	Motor blocking alarm
E004	Drive accelerated running overvoltage	E019	Reserved
E005	Drive decelerated running overvoltage	E020	Closed-loop feedback loss alarm
E006	Drive constant-speed running overvoltage	E021	Water pressure overpressure alarm
E007	Undervoltage alarm during running	E022	Reserved
E008	Motor overload alarm	E023	Water shortage alarm
E009	Drive overload alarm	E024	Reserved
E010	Drive module protection alarm	E025	Reserved
E011	Phase loss alarm at input side	E026	Buffer circuit abnormal alarm
E012	Phase loss alarm at output side	E027	Reserved
E013	Drive module radiator overheat alarm	E028	Keypad parameter copy error alarm
E014	Rectifier module radiator overheat alarm	E029	Wave-by-wave current limiting alarm
E015	External fault alarm	E034	Water pipe break alarm

Chapter V Basic Operation Instructions

5.1 Start operation mode

The HAV-SP series drive's start operation control includes three different ways as follows:

1. Start when the drive gives a run command normally;
2. Start after the automatic fault reset of the drive;
3. Start under the terminal two-wire start protection (the drive starts automatically when the drive is powered on, the fault is cleared or the command channel is switched to the terminal two-wire mode, which is only valid to terminal two-wire control).

The three different start-stop control statuses are described in the following.

5.1.1 Logic block diagram of start when the drive gives a run command normally

The HAV-SP series drive's run command input has three channels namely keypad, terminal and communication, and can be switched freely by input terminal and function code settings.

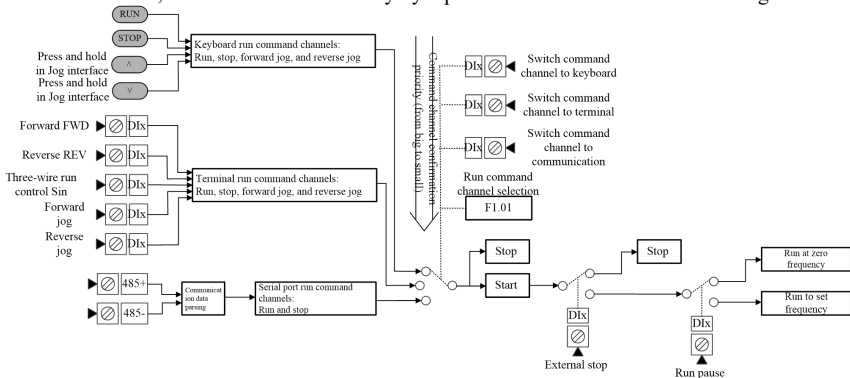

5.1.2 Logic block diagram of start after the automatic fault reset of the drive

The automatic reset function can automatically reset the running faults according to the set times and intervals. When the number of automatic resets is set to 0, it indicates that automatic reset is prohibited and fault protection is performed immediately. Within 2 minutes after the drive operates, if there is no fault, it will automatically clear the number of resets, and accumulate the number of resets from the beginning.

The drive module protection (E010) and external equipment failure (E015) have no automatic reset function. After the automatic reset is completed, it will automatically start and run at the speed tracking.

For safety's sake, use this function with caution, otherwise, it may cause personal injuries and property losses.

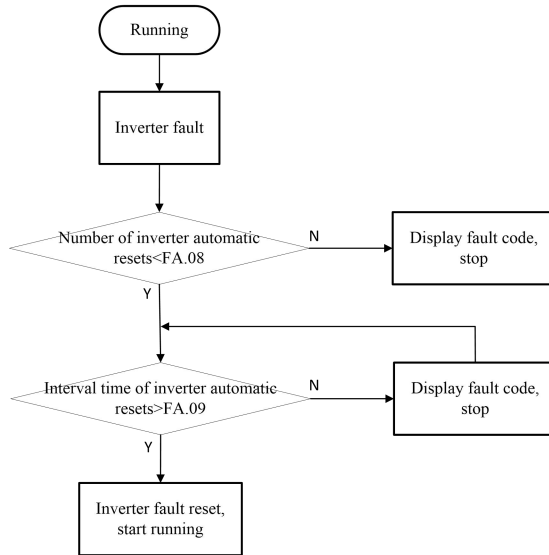

5.1.3 Terminal two-wire start protection and start logic block diagram

The terminal two-wire start protection start can realize that the drive automatically starts when the drive is powered on, the fault is cleared, or the command channel is switched to the terminal two-wire mode, if the terminal run command is valid.

For safety's sake, use this function with caution, otherwise, it may cause personal injuries and property losses.

1. Power on inverter
2. Troubleshoot
3. Switch command channel to terminal two-wire mode

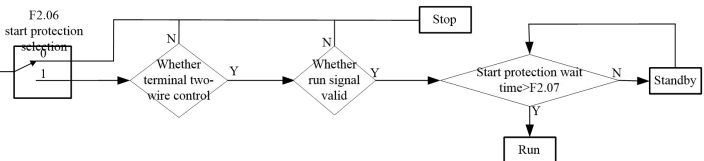

Related parameter table:

Parameter Code	Parameter name	Parameter detailed description	Minimum Unit	Factory value	Change
F1.01	Run command channel selection	0: Keypad run command channel 1: Terminal run command channel 2: Serial port run command channel	1	0	○
F1.24	Running direction setting	0: Forward 1: Reverse	1	0	○
F2.06	Start protection selection (only valid for two-wire control)	This function realizes whether the drive automatically starts running when the drive is powered on, the fault is cleared, or the command channel is switched to the terminal two-wire mode. 0: If the run command is valid, the drive does start, and the drive is in the running	1	0	×

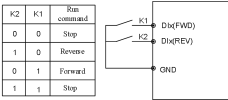
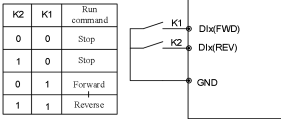
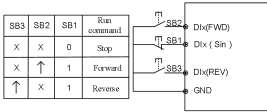
Parameter Code	Parameter name	Parameter detailed description	Minimum Unit	Factory value	Change
		<p>protection state. The drive will not run until the run command terminal is canceled and then the terminal is enabled.</p> <p>1: If the run command is valid, the drive speed tracking starts.</p> <p>Note: For safety, be cautious when setting to 1.</p>			
F2.07	Start protection wait time	Set range: 0.0~10.0s	0.1s	0.0s	○
F2.30	Forward and reverse dead zone time	Set range: 0.00~360.00s	0.01s	0.01s	×
F6.09	Forward/reverse running mode setting	<p>0: Two-wire control mode 1: This mode is the most commonly used two-wire mode. The forward and reverse of the motor are determined by the defined FWD and REV terminal commands.</p>  <p>1: Two-wire control mode 2: This mode uses the defined FWD as the running terminal and the direction is determined by the REV status that defined.</p>  <p>2: Three-wire control mode 1: This mode uses the defined Sin as the enable terminal, the run command is generated by FWD or REV, and both control the operation direction. When the drive operates, the terminal Sin must be closed. The terminal FWD or REV generates a rising edge signal to control the operation and direction of the drive. When the drive stops, the terminal Sin must be disconnected to complete the stop.</p>  <p>3: Three-wire control model 2: This mode uses the defined Sin as the enable terminal, the run command is generated by FWD, and</p>	1	0	×

Parameter Code	Parameter name	Parameter detailed description	Minimum Unit	Factory value	Change
		<p>the direction is controlled by REV. When the drive operates, the terminal Sin must be closed. The terminal FWD generates a rising edge signal, and the drive starts operating. The status of terminal REV determines the operation direction. When the drive stops, the terminal Sin must be disconnected to complete the stop.</p>			
FA.08	Number of automatic resets	FA.08 set range: 0~100 (0 indicates no automatic reset function)	1	0	×
FA.09	Automatic reset interval time	FA.09 set range: 0.1~1000.0s	0.1s	5.0s	×

5.2 Start-stop control

There are three ways to start the HAV-SP series drive:

1. Start from the start frequency: Start at the start frequency set by F2.01, and accelerate to the set frequency after running the hold time set by F2.02 at this frequency.
2. Brake first and then start from the start frequency: First start with the DC braking current set in F2.03 and the DC braking time set in F2.04 for DC braking and then start from the start frequency.

3. Speed tracking and restart: Track the current speed and direction of the motor, and perform smooth start without impact on the motor that is still rotating.

There are three ways to stop the HAV-SP series drive:

1. Deceleration stop: After receiving the stop command, the drive will gradually reduce the output frequency according to the deceleration time, and stop when the frequency decreases to zero.
2. Free running stop: After receiving the stop command, the drive immediately stops the output, and the load stops freely according to the mechanical inertia.
3. Deceleration stop + DC braking: After receiving the stop command, the drive reduces the output frequency according to the deceleration time, and starts the DC braking when reaching the stop braking start frequency.

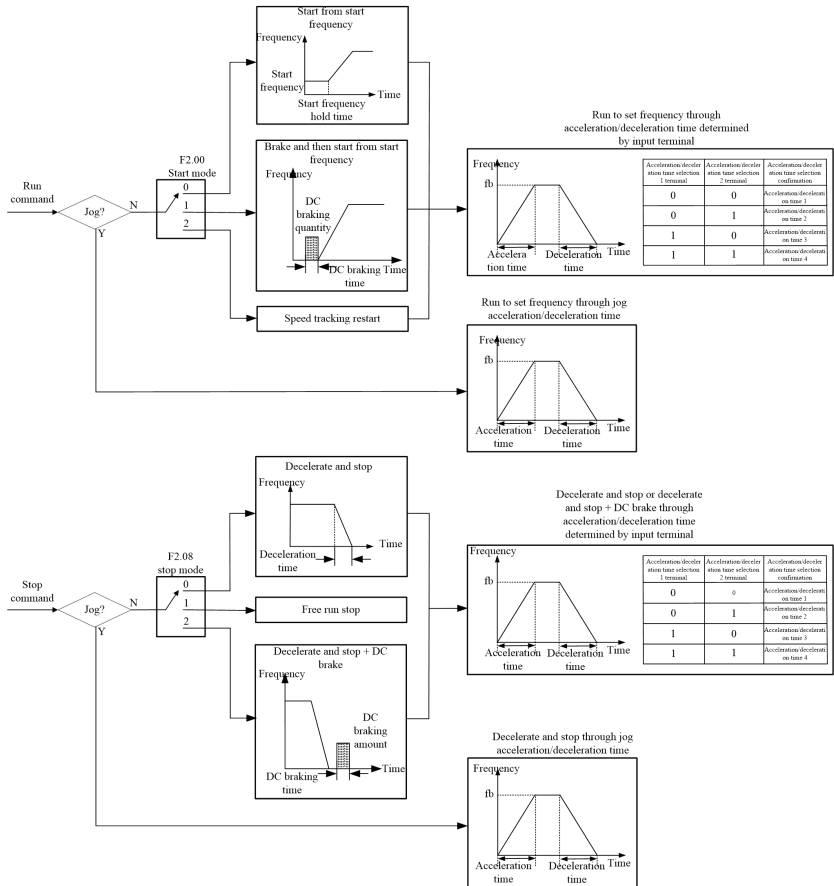

Related parameter table:

Parameter Code	Parameter name	Parameter detailed description	Minimum Unit	Factory value	Change
F1.11	Acceleration time 1	Set range: 0.01~600.00	0.01	Model determination	○
F1.12	Deceleration time 1				○
F1.13	Acceleration/deceleration filtering time	Set range: 0~1000ms (0 indicates on filter)	1ms	0ms	○
F2.00	Start operation mode	LED single digit: Start mode 0: Start from start frequency. 1: Brake and then start from the start frequency. 2: Speed tracking restart. LED tens digit: Speed tracking mode 0: Track down from the frequency	11	00	×

Parameter Code	Parameter name	Parameter detailed description	Minimum Unit	Factory value	Change	
		of shutdown, usually this method is used. 1: Track down from the maximum frequency, suitable for power generation load.				
F2.01	Start frequency	F2.01 set range: 0.20~60.00Hz F2.02 set range: 0.0~10.0s	0.01Hz	0.50Hz	○	
F2.02	Start frequency hold time		0.1s	0.0s	○	
F2.03	Start DC braking current	F2.03 set range: 0.0~150.0% drive rated current	0.1%	100.0%	○	
F2.04	Start DC braking time	F2.04 set range: 0.0~30.0S (0.0 indicates the DC braking does not act)	0.1s	0.0s	○	
F2.05	Acceleration/deceleration mode selection	0: Linear acceleration/deceleration: The output frequency increases or decreases according to a constant slope. 1: Reserved	1	0	×	
F2.08	Stop mode	0: Decelerate and stop 1: Run freely and stop 2: Decelerate and stop + DC brake	1	0	×	
F2.09	DC braking start frequency at stop	F2.09 set range: 0.00~60.00Hz F2.10 set range: 0.00~10.00s F2.11 set range: 0.0~150.0% drive rated current F2.12 set range: 0.0~60.0S (0.0 indicates the DC braking does not act) F2.13 set range: 0~1	0.01Hz	0.00Hz	○	
F2.10	DC braking wait time at stop		0.01s	0.10s	○	
F2.11	DC braking current at stop		0.1%	100.0%	○	
F2.12	DC braking time at stop		0.1s	0.0s	○	
F2.13	Action selection within DC braking wait time at stop		1	1	○	
F2.14	Acceleration time 2		Set range: 0.01~600.00	0.01	Model determination	○
F2.15	Deceleration time 2					○
F2.16	Acceleration time 3	○				
F2.17	Deceleration time 3	○				
F2.18	Acceleration time 4	○				
F2.19	Deceleration time 4	○				
F2.20	Jog run	Set range: 0.10~F1.09	0.01Hz	5.00Hz	○	

Parameter Code	Parameter name	Parameter detailed description	Minimum Unit	Factory value	Change
	frequency				
F2.21	Jog interval time	Set range: 0.0~100.0s	0.1s	0.0s	○
F2.22	Jog acceleration time	Set range: 0.01~600.00s	0.01s	6.00s	○
F2.23	Jog deceleration time				○
F7.08	Speed tracking gain Kp	F7.08 set range: 0~100 F7.09 set range: 1~1000ms F7.10 set range: 0.1~600.0s F7.11 set range: 1~100% F7.12 set range: 1~100%	1	10	○
F7.09	Speed tracking integration time		1ms	50ms	○
F7.10	Speed tracking acceleration and deceleration		0.1s	20.0s	○
F7.11	Speed tracking judgment threshold		1%	10%	○
F7.12	Speed tracking switching completion judgment threshold		1%	3%	○

5.3 Frequency setting

There're many ways for the HAV-SP series drive frequency input, and its input channels can be divided into three types namely the main frequency X, the auxiliary frequency Y, and the combination input. It can be switched freely by setting the terminal function.

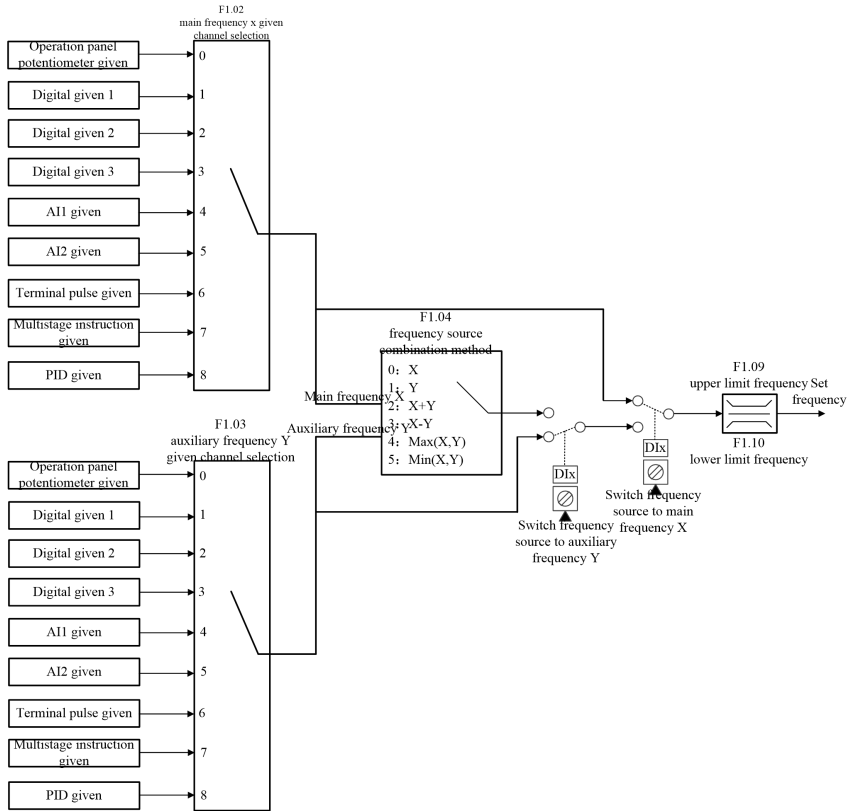

Related parameter table:

Parameter Code	Parameter name	Parameter detailed description	Minimum Unit	Factory value	Change
F1.02	Main frequency x input channel selection	0: Keypad digital potentiometer input 1: Digital input 1 2: Digital input 2 3: Digital input 3 4: AI1 input	1	0	○
	Auxiliary frequency Y input channel selection	5: AI2 input 6: Terminal pulse input 7: Multistage instruction input 8: PID input 9-15: Reserved			
F1.04	Frequency source combination mode	0: X 1: Y 2: X+Y 3: X-Y 4: Max(X,Y) 5: Min(X,Y)	1	0	○
F1.05	Digital	Lower limit frequency ~ upper limit	0.01Hz	50.00Hz	○

Parameter Code	Parameter name	Parameter detailed description	Minimum Unit	Factory value	Change
	setting of auxiliary frequency Y	frequency			
F1.06	Maximum output frequency	Upper limit frequency~650.00Hz	0.01Hz	50.00Hz	×
F1.07	Main frequency x digital setting	Lower limit frequency ~ upper limit frequency	0.01Hz	50.00Hz	○
F1.09	Upper limit frequency	Lower limit frequency ~ maximum output frequency	0.01Hz	50.00Hz	○
F1.10	Lower limit frequency	0.00~upper limit frequency	0.01Hz	0.00Hz	○

5.4 Analog input

The HAV-SP series is configured with 2 analog input terminals (AI1 and AI2 are of 0~10V/0~20mA input, AI1 can select voltage input or current input through jumper J1, and AI2 can select voltage input or current input through jumper J2) and 1 high-speed pulse input terminal. Each input can be filtered independently, and be adjusted. The corresponding input curve can be set by setting the input corresponding to the maximum and minimum values.

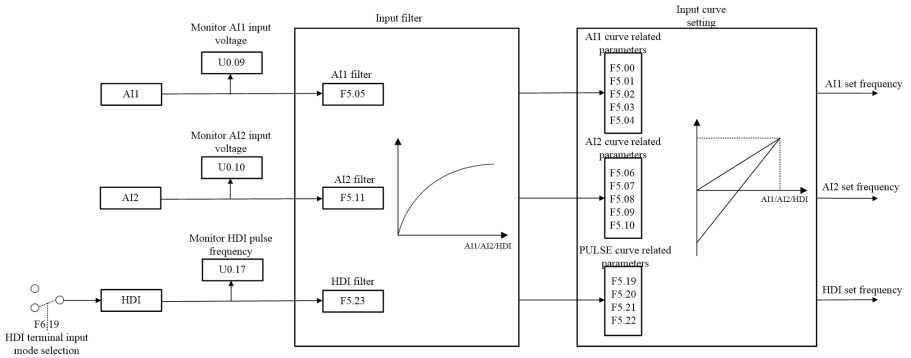

Related parameter table:

Parameter Code	Parameter name	Parameter detailed description	Minimum Unit	Factory value	Change
F5.00	AI1 minimum value	0.00~F5.02	0.01V	0.00V	○
F5.01	Set value corresponding to AI1 minimum value	-100.0%~100.0%	0.1%	0.0%	○

Parameter Code	Parameter name	Parameter detailed description	Minimum Unit	Factory value	Change
F5.02	AI1 maximum value	F5.00~10.00V	0.01V	10.00V	○
F5.03	Set value corresponding to AI1 maximum value	-100.0%~100.0%	0.1%	100.0%	○
F5.04	AI1 zero drift setting	0.00~10.00V	0.01V	0.00V	○
F5.05	AI1 filter time	0~1000ms	1ms	10ms	○
F5.06	AI2 minimum value	0.00~F5.08	0.01V	0.00V	○
F5.07	Set value corresponding to AI2 minimum value	-100.0%~100.0%	0.1%	0.0%	○
F5.08	AI2 maximum value	F5.06~10.00V	0.01V	10.00V	○
F5.09	Set value corresponding to AI2 maximum value	-100.0%~100.0%	0.1%	100.0%	○
F5.10	AI2 zero drift setting	0.00~10.00V	0.01V	0.00V	○
F5.11	AI2 filter time	0~1000ms	1ms	10ms	○
F5.18	Analog automatic zero drift adjustment	0~1	0	0	○
F5.19	PULSE minimum input	0.00~F5.21	0.01KHz	0.00KHz	○
F5.20	Correspondence setting of PULSE minimum input	-100.0%~100.0%	0.1%	0.0%	○
F5.21	PULSE maximum input	F5.19~50.00KHz	0.01KHz	50.00KHz	○
F5.22	Correspondence setting of PULSE maximum input	-100.0%~100.0%	0.1%	100.0%	○
F5.23	PULSE filter	0~1000ms	1ms	10ms	○

Parameter Code	Parameter name	Parameter detailed description	Minimum Unit	Factory value	Change
	time				
F6.19	HDI terminal input mode selection (DI5)	0: Switch input 1: High-frequency pulse input (see F5.19~F5.23)	1	0	×

5.5 Analog output

The HAV-SP series is configured with 2 analog output terminals (AO1 and AO2 are of 0~10V/0~20mA output, AO1 can select voltage input or current input through jumper J3, and AO2 can select voltage input or current input through jumper J4) and 1 high-speed pulse output terminal. The proportional relationship can be adjusted by setting the maximum and minimum values and their corresponding output percentages. The analog output signal can output the operation frequency, output current, output torque, output voltage and output power in a certain proportion.

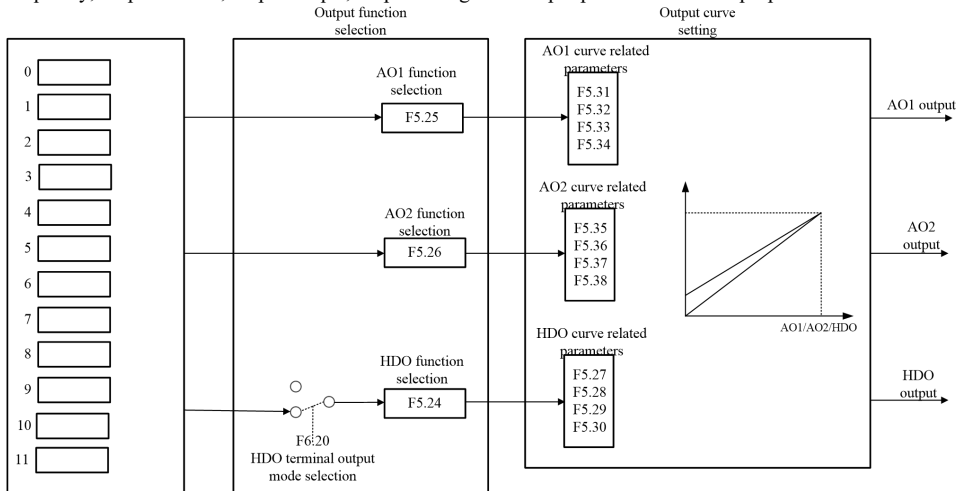

Related parameter table:

Parameter Code	Parameter name	Parameter detailed description	Minimum Unit	Factory value	Change
F5.24	HDO function selection	0: Running frequency (0~Maximum output frequency) 1: Set frequency (0~Maximum output frequency)	1	5	○
F5.25	AO1 function selection	2: Output current (0~2 times rated current)	1	0	○
F5.26	AO2 function selection	3: Output torque (0~2 times rated torque) 4: Output voltage (0~1.2 times rated voltage) 5: Bus voltage (0~1000V)	1	1	○

Parameter Code	Parameter name	Parameter detailed description	Minimum Unit	Factory value	Change
		6: AI1 (0~10V/0~20mA) 7: AI2 (0~10V/0~20mA) 8: Reserved 9: Output power (0~2 times rated frequency) 10: Pulse input (0~50.00KHz) 11: Communication setting (0~1000) 12: Operating frequency after compensation (0~maximum output frequency)			
F5.27	HDO output lower limit	0.0~F5.29	0.1%	0.0%	○
F5.28	HDO output frequency corresponding to lower limit	0.00~50.00KHz	0.01KHz	0.00KHz	○
F5.29	HDO output upper limit	F5.27~100.0%	0.1%	100.0%	○
F5.30	HDO output frequency corresponding to upper limit	0.00~50.00KHz	0.01KHz	50.00KHz	○
F5.31	AO1 output lower limit	0.0~F5.33	0.1%	0.0%	○
F5.32	Corresponding lower limit AO1 output voltage	0.00~10.00V	0.01V	0.00V	○
F5.33	AO1 output upper limit	F5.31~100.0%	0.1%	100.0%	○
F5.34	Corresponding upper limit AO1 output voltage	0.00~10.00V	0.01V	10.00V	○
F5.35	AO2 output lower limit	0.0~F5.37	0.1%	0.0%	○
F5.36	Corresponding lower limit AO2 output voltage	0.00~10.00V	0.01V	0.00V	○
F5.37	AO2 output lower limit	F5.35~100.0%	0.1%	100.0%	○
F5.38	Corresponding upper limit AO2 output voltage	0.00~10.00V	0.01V	10.00V	○

Parameter Code	Parameter name	Parameter detailed description	Minimum Unit	Factory value	Change
F6.20	HDO terminal output mode selection (DO2)	0: Switch output 1: High-frequency pulse output (see F5.27~F5.30)	1	0	×

5.6 Digital input

The HAV-SP series is equipped with 5 DI input terminals and 10 VDI virtual input terminals. All input terminal functions can be programmed through function codes. Among them, DI5 can be selected as a high-frequency pulse input terminal or an ordinary switch input terminal through function code; when it is selected as a high-speed pulse input terminal (HDI), the user can also use the HDI high-speed pulse input as frequency input, count input, or length pulse input.

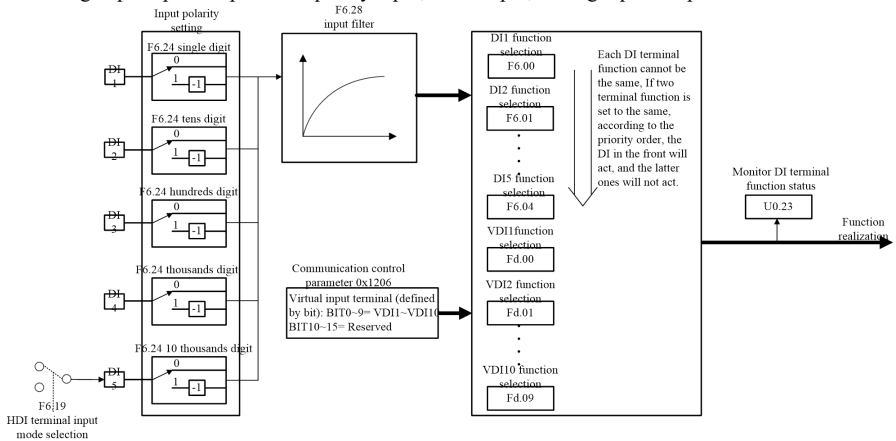

Input function description:

Set value	Function	Description
0	No function	The drive does not operate even if there is a signal input. Unused terminals can be set to having no function to prevent malfunction.
1	Forward running FWD (level + edge)	For terminal two-wire and three-wire control signals, see function code F6.09 description for details.
2	Reverse running REV (level + edge)	
3	Three-wire running control Sin (level)	
4	Forward jog (level)	Used for jog running control under terminal run command mode, the jog running frequency, jog interval time and jog acceleration/deceleration time are defined in F2.20~F2.23.
5	Reverse jog (level)	
6	Free stop (level)	If the function of this terminal is valid, the drive immediately terminates the output, and the load stops freely according to the mechanical inertia.
7	Fault reset (edge signal)	When a fault alarm occurs in the drive, the fault can be

Set value	Function	Description																																																																																
		reset through this terminal. Its function is consistent with the STOP key function of the keypad.																																																																																
8	Run pause (level)	If this terminal is valid during running, the terminal will decelerate to zero frequency running according to the deceleration time. This function is invalid during jog running.																																																																																
9	External fault input	The fault signals of external devices can be input through this terminal, which is convenient for the drive to monitor the faults of external devices. After receiving fault signals from external devices, the drive displays "E015", which is the fault alarm of external devices.																																																																																
10	Frequency setting increase (UP)	The frequency increase or decrease is realized through the control terminal, to perform remote control replacing the keypad. Effective when the main frequency F1.02 = 2 or the auxiliary frequency F1.03 = 2, the acceleration/deceleration rate is set by F6.10.																																																																																
11	Frequency setting decreases (DOWN)																																																																																	
12	Multistage speed terminal 1	By selecting the terminal ON/OFF combination of these functions, you can define up to 16 stages of speed running curves, the frequency of multistage instructions, the selection of acceleration/deceleration time, and the rotating direction are set in group F9.																																																																																
13	Multistage speed terminal 2																																																																																	
14	Multistage speed terminal 3																																																																																	
15	Multistage speed terminal 4																																																																																	
		<table border="1"> <thead> <tr> <th>K4</th> <th>K3</th> <th>K2</th> <th>K1</th> <th>Frequency setting</th> </tr> </thead> <tbody> <tr> <td>OFF</td> <td>OFF</td> <td>OFF</td> <td>OFF</td> <td>Multistage instruction 1</td> </tr> <tr> <td>OFF</td> <td>OFF</td> <td>OFF</td> <td>ON</td> <td>Multistage instruction 2</td> </tr> <tr> <td>OFF</td> <td>OFF</td> <td>ON</td> <td>OFF</td> <td>Multistage instruction 3</td> </tr> <tr> <td>OFF</td> <td>OFF</td> <td>ON</td> <td>ON</td> <td>Multistage instruction 4</td> </tr> <tr> <td>OFF</td> <td>ON</td> <td>OFF</td> <td>OFF</td> <td>Multistage instruction 5</td> </tr> <tr> <td>OFF</td> <td>ON</td> <td>OFF</td> <td>ON</td> <td>Multistage instruction 6</td> </tr> <tr> <td>OFF</td> <td>ON</td> <td>ON</td> <td>OFF</td> <td>Multistage instruction 7</td> </tr> <tr> <td>OFF</td> <td>ON</td> <td>ON</td> <td>ON</td> <td>Multistage instruction 8</td> </tr> <tr> <td>ON</td> <td>OFF</td> <td>OFF</td> <td>OFF</td> <td>Multistage instruction 9</td> </tr> <tr> <td>ON</td> <td>OFF</td> <td>OFF</td> <td>ON</td> <td>Multistage instruction 10</td> </tr> <tr> <td>ON</td> <td>OFF</td> <td>ON</td> <td>OFF</td> <td>Multistage instruction 11</td> </tr> <tr> <td>ON</td> <td>OFF</td> <td>ON</td> <td>ON</td> <td>Multistage instruction 12</td> </tr> <tr> <td>ON</td> <td>ON</td> <td>OFF</td> <td>OFF</td> <td>Multistage instruction 13</td> </tr> <tr> <td>ON</td> <td>ON</td> <td>OFF</td> <td>ON</td> <td>Multistage instruction 14</td> </tr> <tr> <td>ON</td> <td>ON</td> <td>ON</td> <td>OFF</td> <td>Multistage instruction 15</td> </tr> </tbody> </table>	K4	K3	K2	K1	Frequency setting	OFF	OFF	OFF	OFF	Multistage instruction 1	OFF	OFF	OFF	ON	Multistage instruction 2	OFF	OFF	ON	OFF	Multistage instruction 3	OFF	OFF	ON	ON	Multistage instruction 4	OFF	ON	OFF	OFF	Multistage instruction 5	OFF	ON	OFF	ON	Multistage instruction 6	OFF	ON	ON	OFF	Multistage instruction 7	OFF	ON	ON	ON	Multistage instruction 8	ON	OFF	OFF	OFF	Multistage instruction 9	ON	OFF	OFF	ON	Multistage instruction 10	ON	OFF	ON	OFF	Multistage instruction 11	ON	OFF	ON	ON	Multistage instruction 12	ON	ON	OFF	OFF	Multistage instruction 13	ON	ON	OFF	ON	Multistage instruction 14	ON	ON	ON	OFF	Multistage instruction 15
K4	K3	K2	K1	Frequency setting																																																																														
OFF	OFF	OFF	OFF	Multistage instruction 1																																																																														
OFF	OFF	OFF	ON	Multistage instruction 2																																																																														
OFF	OFF	ON	OFF	Multistage instruction 3																																																																														
OFF	OFF	ON	ON	Multistage instruction 4																																																																														
OFF	ON	OFF	OFF	Multistage instruction 5																																																																														
OFF	ON	OFF	ON	Multistage instruction 6																																																																														
OFF	ON	ON	OFF	Multistage instruction 7																																																																														
OFF	ON	ON	ON	Multistage instruction 8																																																																														
ON	OFF	OFF	OFF	Multistage instruction 9																																																																														
ON	OFF	OFF	ON	Multistage instruction 10																																																																														
ON	OFF	ON	OFF	Multistage instruction 11																																																																														
ON	OFF	ON	ON	Multistage instruction 12																																																																														
ON	ON	OFF	OFF	Multistage instruction 13																																																																														
ON	ON	OFF	ON	Multistage instruction 14																																																																														
ON	ON	ON	OFF	Multistage instruction 15																																																																														

Set value	Function	Description																			
		ON	ON	ON	ON	Multistage instruction 16															
16	Acceleration/deceleration time selection 1	The ON/OFF combination of acceleration/deceleration time terminals 1 and 2 can realize the selection of acceleration/deceleration time 1~4. <table border="1" style="margin-left: 20px;"> <tr> <td>K2</td> <td>K1</td> <td>Acceleration/deceleration time selection</td> </tr> <tr> <td>OFF</td> <td>OFF</td> <td>Acceleration/deceleration time 1</td> </tr> <tr> <td>OFF</td> <td>ON</td> <td>Acceleration/deceleration time 1</td> </tr> <tr> <td>ON</td> <td>OFF</td> <td>Acceleration/deceleration time 3</td> </tr> <tr> <td>ON</td> <td>ON</td> <td>Acceleration/deceleration time 4</td> </tr> </table>					K2	K1	Acceleration/deceleration time selection	OFF	OFF	Acceleration/deceleration time 1	OFF	ON	Acceleration/deceleration time 1	ON	OFF	Acceleration/deceleration time 3	ON	ON	Acceleration/deceleration time 4
K2	K1						Acceleration/deceleration time selection														
OFF	OFF						Acceleration/deceleration time 1														
OFF	ON						Acceleration/deceleration time 1														
ON	OFF						Acceleration/deceleration time 3														
ON	ON	Acceleration/deceleration time 4																			
17	Acceleration/deceleration time selection 2																				
18	PLC pause	Used to realize the pause control of the PLC running process. When this terminal is valid, it runs at zero frequency. The PLC running is not counted.																			
19	PLC operation stop and reset	PLC is prohibited from starting when the terminal is valid, deceleration and stop control is implemented for the PLC running process, and the PLC is reset to the initial state.																			
20	PID control pause	PID is temporarily invalid, and the drive maintains the current output frequency without performing PID adjustment.																			
21	PID parameter switching	When the PID parameter switching condition (F8.12) is set to 1 (via terminal switching), the F8.06~F8.08 are used for PID parameters when the terminal is invalid, and F8.09~F8.11 are used when the terminal is valid.																			
22	Counter trigger	Count pulse input port of the built-in counter, the highest pulse frequency: 200Hz, and the current count value can be stored and memorized when power is off. See function codes F6.22 and F6.23 for details.																			
23	Counter reset	Clear the built-in counter of the drive and use it in conjunction with function 22 (counter trigger signal input).																			
24	Length reset	When the function terminal is valid, the actual length is cleared to zero.																			
25	Acceleration/deceleration prohibited (level)	Keep the motor from being affected by any external signal (except stop command), maintain operating at the current speed. This function is invalid during jog running.																			
26	Immediate DC braking	When the stop mode is “decelerate and stop + DC brake”, it is switched to DC brake status when the terminal is valid during stop.																			
27	UP/DOWN setting cleared	When the frequency input channel is set to terminal UP/DN, this function terminal can directly clear the frequency set by UP/DN.																			
28	Control command switched to keypad	If the three terminals or two of them are closed at the same time, the priority is keypad> terminal>																			
29	Control command switched to																				

Set value	Function	Description
	terminal	communication.
30	Control command switched to communication	Note: When switching to terminal two-wire control, the running state changes are affected by the F2.06 parameter; when switching to other control modes, the current running state is maintained.
31	Frequency source switched to the main frequency X	If the above two terminals are closed at the same time, the priority is switching to the main frequency X> switching to the auxiliary frequency Y
32	Frequency source switched to auxiliary frequency Y	
33	High-frequency pulse count reset	When the function terminal is valid, the high-frequency pulse count value recorded by function code U0.16 is cleared.
34	Reserved	Reserved
35	Water shortage	When the water pump mode (F0.04=1) is running, the terminal effectively reports E023 water shortage fault.
36	Reserved	Reserved
37	Reserved	Reserved
38	Fire override mode	When this function is valid, unless the drive is powered off, it cannot be stopped.
39	Pump A maintenance signal	Used to test the operating mode of pump A
40	Pump B maintenance signal	Used to test the operating mode of pump B.
41	Pump C maintenance signal	Used to test the operating mode of pump C.

Related parameter table:

Parameter Code	Parameter name	Parameter detailed description	Minimum Unit	Factory value	Change
F6.00	Function selection of multi-function input terminal DI1	0: No function 1: Forward running FWD (level + edge) 2: Reverse running REV (level + edge) 3: Three-wire running control Sin (level) 4: Forward jog (level) 5: Reverse jog (level) 6: Free stop (level) 7: Fault reset (edge signal) 8: Run pause (level) 9: External fault input	1	1	
		10: Frequency setting increase (UP) 11: Frequency setting decreases (DOWN) 12: Multistage speed terminal 1 13: Multistage speed terminal 2 14: Multistage speed terminal 3 15: Multistage speed terminal 4 16: Acceleration/deceleration time selection 1 17: Acceleration/deceleration time selection 2			
F6.01	Function selection of multi-function input terminal DI2	18: PLC pause 19: PLC operation stop and reset 20: PID control pause 21: PID parameter switching 22: Counter trigger 23: Counter reset 24: Length reset 25: Acceleration/deceleration prohibited		1	
F6.02	Function selection of multi-function input terminal DI3			7	

Parameter Code	Parameter name	Parameter detailed description	Minimum Unit	Factory value	Change
		(level) 26: Immediate DC braking 27: UP/DOWN setting cleared 28: Control command switched to keypad 29: Control command switched to terminal 30: Control command switched to communication			
F6.03	Function selection of multi-function input terminal DI4	31: Frequency source switched to the main frequency X 32: Frequency source switched to auxiliary frequency Y 33: High-frequency pulse count reset 34: Reserved 35: Water shortage fault 36: Reserved 37: Reserved		12	
F6.04	Function selection of multi-function input terminal DI5	38: Fire override mode 39: Pump A maintenance signal 40: Pump B maintenance signal 41: Pump C maintenance signal		13	
F6.19	HDI terminal input mode selection (DI5)	0: Switch input 1: High-frequency pulse input (see F5.19~F5.23)	1	0	×
F6.24	DI input switch polarity 1	00000~11111 LED single digit: DI1 positive/negative logic definition LED tens digit: DI2 positive/negative logic definition LED hundreds digit: DI3 positive/negative logic definition LED thousands digit: DI4 positive/negative logic definition LED 10 thousands digit: DI5 positive/negative logic definition	11111	11111	○
F6.28	DI filter time	0~1000ms	1ms	5ms	○
Fd.00	VDI1 terminal function selection	Same as F6.00~F6.08 function code setting.	1	0	×
Fd.01	VDI2 terminal function selection		1	0	×

Parameter Code	Parameter name	Parameter detailed description	Minimum Unit	Factory value	Change
Fd.02	VDI3 terminal function selection		1	0	×
Fd.03	VDI4 terminal function selection		1	0	×
Fd.04	VDI5 terminal function selection		1	0	×
Fd.05	VDI6 terminal function selection		1	0	×
Fd.06	VDI7 terminal function selection		1	0	×
Fd.07	VDI8 terminal function selection		1	0	×
Fd.08	VDI9 terminal function selection		1	0	×
Fd.09	VDI10 terminal function selection		1	0	×

5.7 Digital output

The HAV-SP series is equipped with two open collector output terminals, one relay output terminal, and five VDO virtual output terminals. All digital output terminal functions can be programmed through function codes. Among them, the high-speed pulse output terminal HDO can also be set to high-speed pulse output or switch output through function code selection.

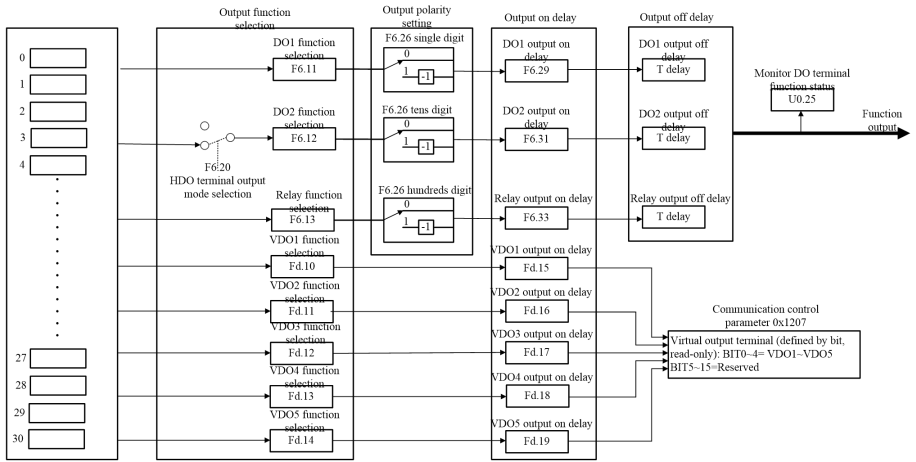

Output function description:

Set value	Function	Description
0	No output	The output terminal has no function.
1	Drive running signal (RUN)	The drive is under the running status and outputs an indication signal.
2	Frequency arrival signal (FAR)	Refer to the function description of F6.18.
3	Frequency level detection signal (FDT1)	Refer to the function description of F6.14~F6.15.
4	Frequency level detection signal (FDT2)	Refer to the function description of F6.16~F6.17.
5	Overload detection signal(OL)	If the output current of the drive exceeds the FA.15 overload detection level, it outputs an indication signal after FA.16 overload detection time.
6	Undervoltage lockout stopping (LU)	When the DC bus voltage is lower than the undervoltage limit level, an indication signal is output, and the LED displays “P.oFF”.
7	External fault stop (EXT)	When the drive has an external fault trip alarm (E015), it outputs an indication signal.
8	Frequency upper limit (FHL)	When the set frequency \geq the upper limit frequency and the operation frequency reaches the upper limit, an indication signal is output.
9	Frequency lower limit (FLL)	When the set frequency \leq the lower limit frequency and the operation frequency reaches the lower limit, an indication signal is output.
10	Drive running at zero frequency	When the drive output frequency is less than or equal to FC.10 zero frequency arrival range, and under the operation status, an indication signal is output.
11	PLC phase running completion	After the simple PLC phase operation is completed, an indication signal (single pulse signal, width 250ms) is output.
12	PLC cycle completion	After the simple PLC completes one operation cycle, an indication signal (single pulse signal, width 250ms) is output.

Set value	Function	Description
13	Set count value arrival	Refer to F6.22~F6.23 function description.
14	Specified count value arrival	
15	Set length arrival	When the actual length $U0.15 \geq FC.11$ set length, an indication signal is output.
16	Drive ready to run	When this signal output is valid, it indicates that the drive has no fault, the bus voltage is normal, and the drive operation prohibition terminal is invalid. In this case, the start command can be accepted.
17	Drive fault	If the drive fails, an indication is output.
18	Reserved	Reserved function.
19	Set cumulative running time arrival	When the accumulated running time of the drive (U0.27) reaches the running cutoff time (F0.02) of the drive, an indication signal is output.
20	Forward running	The drive is under the forward running status and outputs an indication signal.
21	Reverse running	The drive is under the reserve running status and outputs an indication signal.
22	Reserved	Reserved function.
23	Water supply sleep running indication	During water supply application, the drive is under the sleep status and outputs an indication signal.
24	Water pipe overpressure indication	During water supply application, the drive judges that the water pipe is overpressure at the time and outputs an indication signal.
25	Water pipe under-pressure indication	During water supply application, the drive judges that the water pipe is under-pressure at the time and outputs an indication signal.
26	Water pipe shortage indication	During water supply application, the drive judges that the water pipe is short of water at the time and outputs an indication signal.
27	Water tank shortage indication	During water supply application, if the drive finds that the water tank is in short of water at any time, it outputs an indication signal.
28	Water pipe burst indication	During water supply application, if the drive finds that the water pipe burst at any time, it outputs an indication signal.

Related parameter table:

Parameter Code	Parameter name	Parameter detailed description	Minimum Unit	Factory value	Change
F6.11	Open collector output terminal DO1	0: No output 1: Drive running signal (RUN) 2: Frequency arrival signal (FAR) 3: Frequency level detection signal (FDT1) 4: Frequency level detection signal (FDT2) 5: Overload detection signal(OL) 6: Undervoltage lockout stopping (LU) 7: External fault stop (EXT) 8: Frequency upper limit (FHL) 9: Frequency lower limit (FLL) 10: Drive running at zero frequency 11: PLC phase running completion 12: PLC cycle completion	1	0	×
F6.12		13: Set count value arrival 14: Specified count value arrival	1	1	×

Parameter Code	Parameter name	Parameter detailed description	Minimum Unit	Factory value	Change
	Open collector output terminal DO (HDO terminal)	15: Set length arrival 16: Drive ready to run (RDY) 17: Drive fault 18: Reserved 19: Set cumulative running time arrival 20: Forward running 21: Reverse running 22: Reserved 23: Water supply sleep running indication 24: Water pipe overpressure indication 25: Water pipe under-pressure indication 26: Water pipe shortage indication 27: Water tank shortage indication 28: Water pipe break indication			
F6.13	Relay output function (TA/TB/TC)		1	17	×
F6.26	DO output switch polarity 1	00000~11111	11111	11111	○
F6.29	DO1 output on delay	Set range: 0.0~600.0s This function code defines the delay from the status change of the switch output terminal and the relay to the output change.	0.1s	0.0s	○
F6.30	DO1 output off delay		0.1s	0.0s	○
F6.31	DO2 output on delay		0.1s	0.0s	○
F6.32	DO2 output off delay		0.1s	0.0s	○
F6.33	Relay output on delay		0.1s	0.0s	○
F6.34	Relay output off delay		0.1s	0.0s	○
Fd.10	VDO1 terminal function selection		Same as F6.11~F6.13 function code setting.	1	0
Fd.11	VDO2 terminal function selection	1		0	×
Fd.12	VDO3 terminal function	1		0	×

Parameter Code	Parameter name	Parameter detailed description	Minimum Unit	Factory value	Change
	selection				
Fd.13	VDO4 terminal function selection		1	0	×
Fd.14	VDO5 terminal function selection		1	0	×
Fd.15	VDO1 output on delay	Same as F6.29~F6.34 function code setting.	0.1s	0.0s	○
Fd.16	VDO2 output on delay		0.1s	0.0s	○
Fd.17	VDO3 output on delay		0.1s	0.0s	○
Fd.18	VDO4 output on delay		0.1s	0.0s	○
Fd.19	VDO5 output on delay		0.1s	0.0s	○

5.8 Simple PLC

The simple PLC function is a multistage speed generator. The drive can automatically change the operation frequency and direction according to the run time to meet the process requirements. This function used to be completed under the assistance of an external PLC. Now it can be realized by the drive itself.

This series of drives can realize 16-stage speed control, and there are 4 groups of acceleration/deceleration time for selection.

When the set PLC completes a cycle (or a stage), an ON signal can be output from the open collector output terminal or relay.

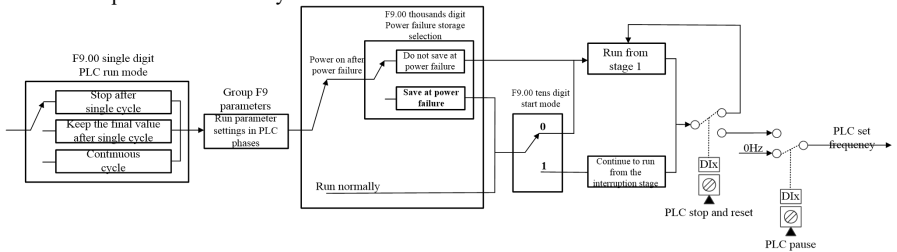

Related parameter table:

Parameter Code	Parameter name	Parameter detailed description	Minimum Unit	Factory value	Change
F9.00	Simple PLC run mode	LED single digit: PLC run mode 0: No action 1: Stop after a single cycle	1111	0004	×

Parameter Code	Parameter name	Parameter detailed description	Minimum Unit	Factory value	Change
	selection	2: Keep the final value after a single cycle 3: Continuous cycle 4: DI selective operation LED tens digit: Start mode 0: Start running from the first stage 1: Continue running from the stage of interruption LED hundreds digit: Stage time unit selection 0: Second 1: Minute LED thousands digit: Store at power failure 0: Do not store at power failure 1: Stage at power failure storage interruption			
F9.01	Running stages	1~16	1	16	○
F9.02	Multistage instruction 1	Lower limit frequency ~ upper limit frequency	0.01Hz	20.00Hz	○
F9.03	Stage 1 instruction setting	LED single digit: 0: Multistage instruction 1 (F9.02) 1: AI1 2: AI2 3: Pulse frequency 4: Communication 5: Keypad digital potentiometer input 6: Reserved LED tens digit: 0: Acceleration/deceleration time 1 1: Acceleration/deceleration time 2 2: Acceleration/deceleration time 3 3: Acceleration/deceleration time 4 LED hundreds digit: 0: Forward running 1: Reverse running Note: Only the LED single digit frequency source of stage 1 instruction can be set.	111	005	○
F9.04	Stage 1 instruction running time	Set range: 0.1~6000.0 Note: For the time unit selection, see F9.00 hundreds digit setting.	0.1	10.0	○
F9.05	Multistage instruction 2	Stage X instruction (F9.05, F9.08, F9.11, F9.14, F9.17, F9.20, F9.23, F9.26, F9.29, F9.32, F9.35、F9.38, F9.41, F9.44, and F9.47) setting range: Lower limit frequency ~ upper limit frequency	0.01Hz	20.00Hz	○
F9.06	Stage 2 instruction setting	Lower limit frequency ~ upper limit frequency	111	000	○
F9.07	Stage 2 instruction running time	Stage X instruction (F9.06, F9.09, F9.12, F9.15, F9.18, F9.21, F9.24, F9.27, F9.30, F9.33, F9.36、F9.39, F9.42, F9.45, and	0.1	10.0	○

Parameter Code	Parameter name	Parameter detailed description	Minimum Unit	Factory value	Change
F9.08	Multistage instruction 3	F9.48) setting range: LED single digit: 0: Multistage instruction x 1: Reserved	0.01Hz	20.00Hz	○
F9.09	Stage 3 instruction setting	LED tens digit: 0: Acceleration/deceleration time 1 1: Acceleration/deceleration time 2 2: Acceleration/deceleration time 3 3: Acceleration/deceleration time 4	111	000	○
F9.10	Stage 3 instruction running time	LED hundreds digit: 0: Forward running 1: Reverse running	0.1	10.0	○
F9.11	Multistage instruction 4	Stage X instruction running time (F9.07, F9.10, F9.13, F9.16, F9.19, F9.22, F9.25, F9.28, F9.31, F9.34, F9.37, F9.40, F9.43, F9.46, and F9.49) setting range: 0.1~6000.0	0.01Hz	20.00Hz	○
F9.12	Stage 4 instruction setting	Note: For the time unit selection, see F9.00 hundreds digit setting.	111	000	○
F9.13	Stage 4 instruction running time		0.1	10.0	○
F9.14	Multistage instruction 5		0.01Hz	20.00Hz	○
F9.15	Stage 5 instruction setting		111	000	○
F9.16	Stage 5 instruction running time		0.1	10.0	○
F9.17	Multistage instruction 6		0.01Hz	20.00Hz	○
F9.18	Stage 6 instruction setting		111	000	○
F9.19	Stage 6 instruction running time		0.1	10.0	○
F9.20	Multistage instruction 7		0.01Hz	20.00Hz	○
F9.21	Stage 7 instruction setting		111	000	○
F9.22	Stage 7 instruction running time		0.1	10.0	○
F9.23	Multistage instruction 8		0.01Hz	20.00Hz	○

Parameter Code	Parameter name	Parameter detailed description	Minimum Unit	Factory value	Change
F9.24	Stage 8 instruction setting		111	000	○
F9.25	Stage 8 instruction running time		0.1	10.0	○
F9.26	Multistage instruction 9		0.01Hz	20.00Hz	○
F9.27	Stage 9 instruction setting		111	000	○
F9.28	Stage 9 instruction running time		0.1	10.0	○
F9.29	Multistage instruction 10		0.01Hz	20.00Hz	○
F9.30	Stage 10 instruction setting		111	000	○
F9.31	Stage 10 instruction running time		0.1	10.0	○
F9.32	Multistage instruction 11		0.01Hz	20.00Hz	○
F9.33	Stage 11 instruction setting		111	000	○
F9.34	Stage 11 instruction running time		0.1	10.0	○
F9.35	Multistage instruction 12		0.01Hz	20.00Hz	○
F9.36	Stage 12 instruction setting		111	000	○
F9.37	Stage 12 instruction running time		0.1	10.0	○
F9.38	Multistage instruction 13		0.01Hz	20.00Hz	○
F9.39	Stage 13 instruction setting		111	000	○

Parameter Code	Parameter name	Parameter detailed description	Minimum Unit	Factory value	Change
F9.40	Stage 13 instruction running time		0.1	10.0	○
F9.41	Multistage instruction 14		0.01Hz	20.00Hz	○
F9.42	Stage 14 instruction setting		111	000	○
F9.43	Stage 14 instruction running time		0.1	10.0	○
F9.44	Multistage instruction 15		0.01Hz	20.00Hz	○
F9.45	Stage 15 instruction setting		111	000	○
F9.46	Stage 15 instruction running time		0.1	10.0	○
F9.47	Multistage instruction 16		0.01Hz	20.00Hz	○
F9.48	Stage 16 instruction setting		111	000	○
F9.49	Stage 16 instruction running time		0.1	10.0	○

5.9 Multistage speed operation

Set the parameters when using the drive for multistage speed operation. The HAV-SP drive can set 16-stage speed, which is selected by the combination code of multistage speed terminals 1~4, corresponding to multistage speed 1 to multistage speed 16 respectively.

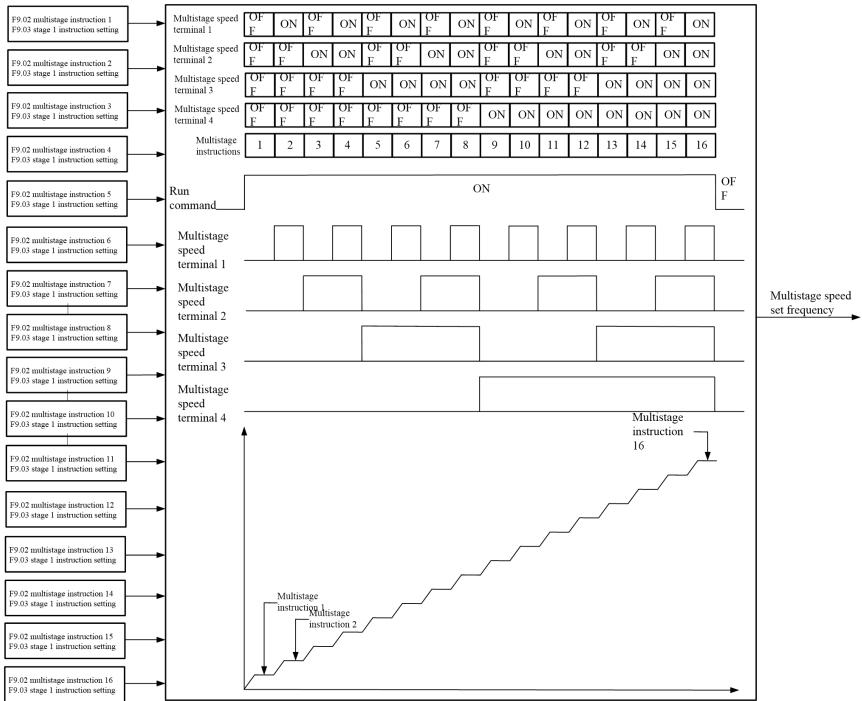

Related parameter table:

Parameter Code	Parameter name	Parameter detailed description	Minimum Unit	Factory value	Change
F9.00	Simple PLC run mode selection	LED single digit: PLC run mode 0: No action 1: Stop after a single cycle 2: Keep the final value after a single cycle 3: Continuous cycle 4: DI selective operation LED tens digit: Start mode 0: Start running from the first stage of interruption 1: Continue running from the stage of interruption LED hundreds digit: Stage time unit selection 0: Second 1: Minute LED thousands digit: Store at power failure 0: Do not store at power failure 1: Stage at power failure storage interruption	1111	0004	×
F9.01	Running stages	1~16	1	16	○

Parameter Code	Parameter name	Parameter detailed description	Minimum Unit	Factory value	Change
F9.02	Multistage instruction 1	Lower limit frequency ~ upper limit frequency	0.01Hz	20.00Hz	○
F9.03	Stage 1 instruction setting	LED single digit: 0: Multistage instruction 1 (F9.02) 1: AI1 2: AI2 3: Pulse frequency 4: Communication 5: Keypad digital potentiometer input 6: Reserved LED tens digit: 0: Acceleration/deceleration time 1 1: Acceleration/deceleration time 2 2: Acceleration/deceleration time 3 3: Acceleration/deceleration time 4 LED hundreds digit: 0: Forward running 1: Reverse running Note: Only the LED single digit frequency source of stage 1 instruction can be set.	111	005	○
F9.04	Stage 1 instruction running time	Set range: 0.1~6000.0 Note: For the time unit selection, see F9.00 hundreds digit setting.	0.1	10.0	○
F9.05	Multistage instruction 2	Stage X instruction (F9.05, F9.08, F9.11, F9.14, F9.17, F9.20, F9.23, F9.26, F9.29, F9.32, F9.35、F9.38, F9.41, F9.44, and F9.47) setting range:	0.01Hz	20.00Hz	○
F9.06	Stage 2 instruction setting	Lower limit frequency ~ upper limit frequency	111	000	○
F9.07	Stage 2 instruction running time	Stage X instruction (F9.06, F9.09, F9.12, F9.15, F9.18, F9.21, F9.24, F9.27, F9.30, F9.33, F9.36、F9.39, F9.42, F9.45, and F9.48) setting range:	0.1	10.0	○
F9.08	Multistage instruction 3	LED single digit: 0: Multistage instruction x 1: Reserved	0.01Hz	20.00Hz	○
F9.09	Stage 3 instruction setting	LED tens digit: 0: Acceleration/deceleration time 1 1: Acceleration/deceleration time 2 2: Acceleration/deceleration time 3 3: Acceleration/deceleration time 4	111	000	○
F9.10	Stage 3 instruction running time	LED hundreds digit: 0: Forward running 1: Reverse running	0.1	10.0	○
F9.11	Multistage instruction 4	Stage X instruction running time (F9.07, F9.10, F9.13, F9.16, F9.19, F9.22, F9.25, F9.28, F9.31, F9.34, F9.37、F9.40, F9.43, F9.46, and F9.49) setting range:	0.01Hz	20.00Hz	○
F9.12	Stage 4 instruction setting		111	000	○
F9.13	Stage 4 instruction running time		0.1	10.0	○
F9.14	Multistage instruction 5		0.01Hz	20.00Hz	○

Parameter Code	Parameter name	Parameter detailed description	Minimum Unit	Factory value	Change
F9.15	Stage 5 instruction setting	0.1~6000.0 Note: For the time unit selection, see F9.00 hundreds digit setting.	111	000	○
F9.16	Stage 5 instruction running time		0.1	10.0	○
F9.17	Multistage instruction 6		0.01Hz	20.00Hz	○
F9.18	Stage 6 instruction setting		111	000	○
F9.19	Stage 6 instruction running time		0.1	10.0	○
F9.20	Multistage instruction 7		0.01Hz	20.00Hz	○
F9.21	Stage 7 instruction setting		111	000	○
F9.22	Stage 7 instruction running time		0.1	10.0	○
F9.23	Multistage instruction 8		0.01Hz	20.00Hz	○
F9.24	Stage 8 instruction setting		111	000	○
F9.25	Stage 8 instruction running time		0.1	10.0	○
F9.26	Multistage instruction 9		0.01Hz	20.00Hz	○
F9.27	Stage 9 instruction setting		111	000	○
F9.28	Stage 9 instruction running time		0.1	10.0	○
F9.29	Multistage instruction 10		0.01Hz	20.00Hz	○
F9.30	Stage 10 instruction setting		111	000	○
F9.31	Stage 10 instruction running time		0.1	10.0	○
F9.32	Multistage instruction 11		0.01Hz	20.00Hz	○
F9.33	Stage 11 instruction setting		111	000	○

Parameter Code	Parameter name	Parameter detailed description	Minimum Unit	Factory value	Change
F9.34	Stage 11 instruction running time		0.1	10.0	○
F9.35	Multistage instruction 12		0.01Hz	20.00Hz	○
F9.36	Stage 12 instruction setting		111	000	○
F9.37	Stage 12 instruction running time		0.1	10.0	○
F9.38	Multistage instruction 13		0.01Hz	20.00Hz	○
F9.39	Stage 13 instruction setting		111	000	○
F9.40	Stage 13 instruction running time		0.1	10.0	○
F9.41	Multistage instruction 14		0.01Hz	20.00Hz	○
F9.42	Stage 14 instruction setting		111	000	○
F9.43	Stage 14 instruction running time		0.1	10.0	○
F9.44	Multistage instruction 15		0.01Hz	20.00Hz	○
F9.45	Stage 15 instruction setting		111	000	○
F9.46	Stage 15 instruction running time		0.1	10.0	○
F9.47	Multistage instruction 16		0.01Hz	20.00Hz	○
F9.48	Stage 16 instruction setting		111	000	○
F9.49	Stage 16 instruction running time		0.1	10.0	○

5.10 PID control

The PID control is a commonly used method for process control. By performing proportional, integral, and differential operations on the feedback signal of the controlled quantity and the quantity of the target quantity signal, the output frequency of the drive is adjusted to form a

negative feedback system, so that the controlled quantity is stable on the target quantity. Suitable for process control such as flow control, pressure control and temperature control.

The basic block diagram of a working PID control is as follows:

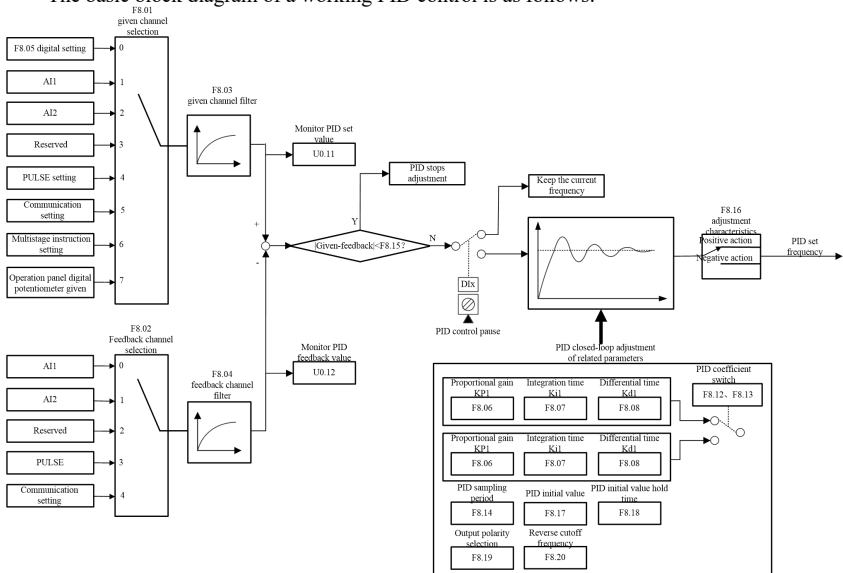

The basic block diagram of PID control for water supply application is as follows (used when F0.04 industry code is the special drive for water supply):

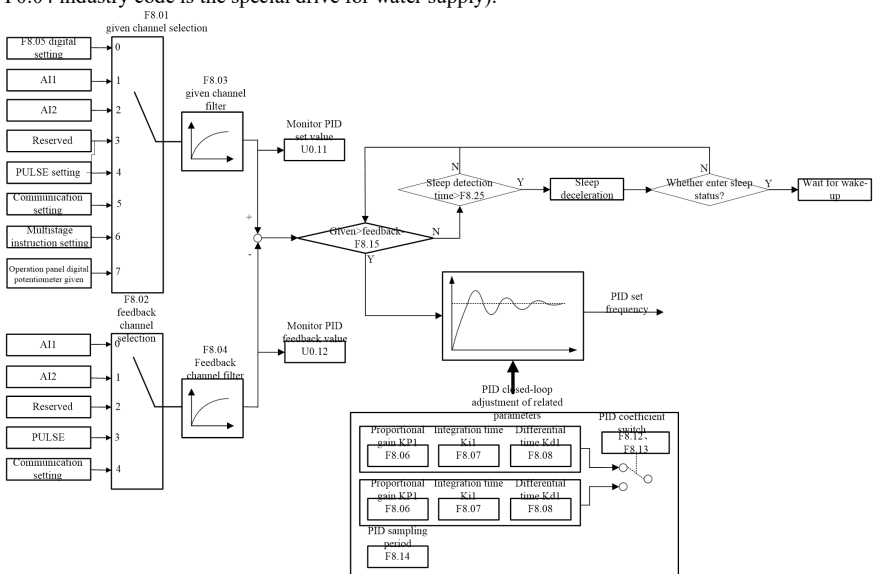

The brief of PID control working principle and the introduction of adjustment method:

Proportional adjustment (K_p): When there is a deviation between the feedback and the input, the output and the deviation are adjusted in proportion. If the deviation is constant, the adjustment amount is also constant. Proportional adjustment can quickly respond to changes in feedback, but just proportional adjustment cannot achieve non-differential control. The larger the proportional gain, the faster the adjustment speed of the system, but if it is too large, oscillation will occur. The adjustment method is to first set the integration time to be very long and the differential time to zero. Use only proportional adjustment to make the system run, change the input quantity, and observe the stable deviation (static difference) between the feedback signal and the input quantity. If the static difference is in the direction of target value changes (for example, increasing the input quantity, the feedback quantity is always less than the target value after the system is stable), continue to increase the proportional gain, otherwise decrease the proportional gain, and repeat the above process until the static difference is relatively small.

Integration time (T_i): When there is a deviation between the feedback and the input value, the output adjustment accumulates continuously. If the deviation persists, the adjustment increases constantly, until there is no deviation. The integral regulator can effectively eliminate static difference. If the integral regulator is too strong, there will be repeated overshoot, making the system unstable until oscillation occurs. The characteristics of the oscillation caused by excessive integration are as follows: The feedback signal swings up and down at an input quantity, and the swing gradually increases until it oscillates. The adjustment of the integration time parameter is generally from large to small, gradually adjust the integration time, and observe the effect of the system adjustment until the stable speed of the system reaches the requirements.

Differential time (T_d): When the deviation between feedback and input changes, an adjustment proportional to the deviation change rate is output. The adjustment is only related to the direction and magnitude of the deviation change, and has nothing to do with the direction and magnitude of the deviation itself. The function of differential adjustment is to adjust according to the changing trend when the feedback signal changes, thus to suppress the change of the feedback signal. Please use the differential regulator with caution, because the differential regulation is easy to amplify the interference of the system, especially the interference with a higher change frequency.

General steps for PID parameter setting

a. Determine the proportional gain K_p

When determining the proportional gain K_p , first remove the integral and differential items of PID. Generally, assumed $T_i = 0$ and $T_d = 0$ (for details, see the description of PID parameter setting), so that the PID is of pure proportional adjustment. The input is set to 60%~70% of the maximum value allowed by the system. The proportional gain K_p is increased from 0 gradually until the system oscillates; in turn, the proportional gain K_p is gradually decreased from this time until the system oscillation disappears. In this case, the proportional gain K_p is recorded, and the proportional gain K_p of PID is set to 60%~70% of the current value. The proportional gain K_p debugging is completed.

b. Determine the integration time T_i

After the proportional gain K_p is determined, set a larger initial value of the integration time T_i , and then gradually decrease T_i until the system oscillates, and then in turn, increase T_i gradually until the system oscillation disappears. Record the T_i at this time and set the integration time constant T_i of PID to 150%~180% of the current value. The integration time constant T_i debugging is completed.

c. Determine the differential time T_d

Generally, the differential time T_d needs not to be set (0). To set, the method is the same with that of determining K_p and T_i , taking 30% without oscillation.

d. The system is debugged with or without load, and then the PID parameters are fine-tuned until the requirements are met.

Related parameter table:

Parameter Code	Parameter name	Parameter detailed description	Minimum Unit	Factory value	Change
F8.00	PID operation control selection	0: Disable (Ready mode) 1: Enable (Ready mode)	1	0	×
F8.01	Target value channel selection	0: F8.05 digital input; 1: AI1; 2: AI2; 3: Reserved 4: PULSE setting; 5: Communication setting 6: Multistage instruction setting 7: Keypad digital potentiometer input 8: Reserved	1	0	×
F8.02	Feedback channel selection	0: AI1; 1: AI2; 2: Reserved 3: Pulse 4: Communication setting	1	0	×
F8.03	Target value channel filter	Set range: 0~1000ms	1ms	10ms	○
F8.04	Feedback channel filter		1ms	10ms	○
F8.05	Target value digital setting	Universal drive mode setting range: 0.0~100.0% Set range of professional drive mode for water supply : 0.0~F8.23	0.1% Or 0.1bar	0.0% Or 0.0bar	○
F8.06	Proportional gain Kp1	Set range: 0~1000	1	10	○
F8.07	Integration time Ti1	Set range: 1~10000ms	1ms	500ms	○
F8.08	Differential time Td1	Set range: 0~10000ms	1ms	0ms	○
F8.09	Proportional gain Kp2	F8.09 set range: 0~1000 F8.10 set range: 1~10000ms F8.11 set range: 0~10000ms	1	5	○
F8.10	Integration time Ti2		1ms	2000ms	○
F8.11	Differential time Td2		1ms	0ms	○
F8.12	Gain switching conditions	0: Do not switch 1: Switch through DI terminal 2: Switch automatically based on deviation 3: Switch automatically according to PID output	1	0	○

Parameter Code	Parameter name	Parameter detailed description	Minimum Unit	Factory value	Change
F8.13	Gain switching threshold	Set range: 0.0~100.0%	0.1%	0.0%	○
F8.14	PID sampling period	Set range: 1~60000ms	1ms	1ms	○
F8.15	Deviation limit	Set range: 0.0~50.0%	0.1%	0.0%	○
F8.16	Closed-loop regulation features	0: Positive action 1: Negative action	1	0	○
F8.17	PID initial value	F8.17 set range: 0.0~100.0% F8.18 set range: 0.00~600.00s	0.1%	0.0%	×
F8.18	PID initial value hold time		0.01s	0.00s	×
F8.19	Closed-loop output polarity selection	0: Closed-loop output is negative, run at zero-frequency 1: Closed-loop output is negative, reverse	1	0	○
F8.20	PID reverse cutoff frequency	Set range: 0.00~upper limit frequency	0.01Hz	2.00Hz	×
F8.21	PID feedback loss detection value	F8.21 set range: 0.0~100.0% F8.22 set range: 0.0~200.0s (0.0s indicates no detection)	0.1%	10.0%	○
F8.22	PID feedback loss detection time		0.1s	0.0s	○
F8.23	Maximum sensor range	Set range: 0.0~200.0bar	0.1bar	10.0bar	○
F8.24	Water supply sleep selection	0: Automatic sleep 1: Run at lower limit frequency	1	0	○
F8.25	Water supply sleep detection time	F8.25 set range: 0.0~3600.0s F8.26 set range: 0.01~600.00s	0.1s	2.0s	○
F8.26	Water supply sleep deceleration time		0.01s	30.00s	○

Parameter Code	Parameter name	Parameter detailed description	Minimum Unit	Factory value	Change
F8.27	Water supply wake pressure tolerance	F8.27 set range: 0.0~100.0% (100.0% is the set pressure value) F8.28 set range: 0.0~3600.0s	0.1%	10.0%	○
F8.28	Water supply wake detection time		0.1s	2.0s	○
F8.29	Water pressure overpressure alarm detection value	Set range: 0.0~100.0% (Do not test when set to 0, 100.0% is the maximum range of pressure sensor)	0.1%	90.0%	○
F8.30	Water pressure undervoltage alarm detection value	Set range: 0.0~100.0% (Do not test when set to 0, 100.0% is the maximum range of pressure sensor)	0.1%	0.0%	○
F8.31	Water pressure abnormal alarm detection time	Set range: 0.0~3600.0s	0.1s	50.0s	○
F8.32	Water shortage alarm set value	F8.32 set range: 0.0~100.0% (100.0% is the set pressure value) F8.33 set range: 0.0~3600.0s F8.34 set range: 0~10000min (0min indicate there's no water shortage restart function)	0.1%	0.0%	○
F8.33	Water shortage alarm detection time		0.1s	20.0s	○
F8.34	Water shortage restart wait time		1min	0min	○
F8.35	Water supply absolute sleep detection time	Setting range: 0~3600.0s When the drive sleeps and decelerates to the lower limit frequency, it will run at the lower limit frequency for the time defined by F8.35 and then go to zero frequency operation.	0.1s	10.0s	○

5.11 Multi-pump control

Multi-pump control function can control the automatic switch of multiple pumps through

a frequency converter and multi-pump control expansion card.

Automatic control mode: According to the actual pressure can automatically add pump, reduce pump, pump change, maintenance stop, sleep standby.

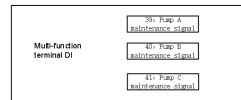
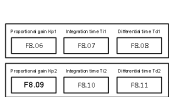
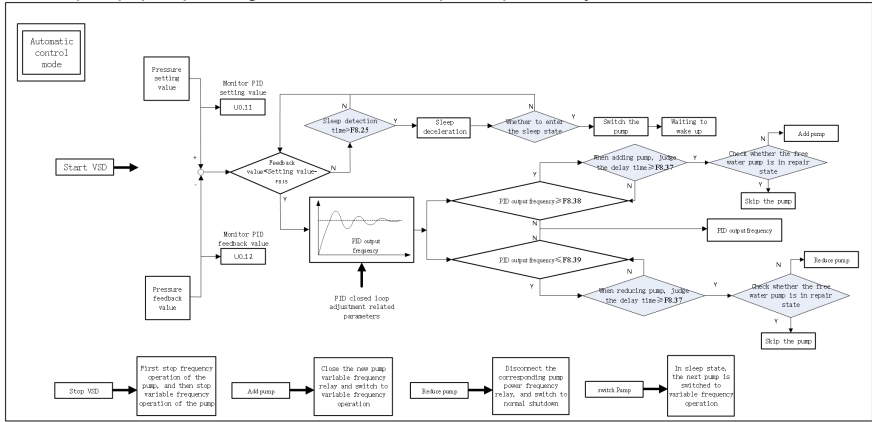

Parameter Code	Parameter Name	Parameter detailed description	Minimum Unit	Factory Value	Change
F8.00	PID operation control selection	0: Disable (Ready mode) 1: Enable (Ready mode)	1	0	×
F8.01	Target value channel selection	When the frequency input channel is selected to 8, the drive operation mode is process PID control. 0: F8.05 digital input; 1: AI1; 2: AI2; 3: Reserved 4: PULSE setting; 5: Communication setting 6: Multistage instruction setting 7: Keypad digital potentiometer input 8: Reserved	1	0	×

Parameter Code	Parameter Name	Parameter detailed description	Minimum Unit	Factory Value	Change
F8.02	Feedback channel selection	This function code is used to select the PID feedback channel. 0: AI1; 1: AI2; 2: Reserved 3: Pulse 4: Communication setting	1	0	×
F8.03	Target value channel selection	Set range: 0~1000ms	1ms	10ms	○
F8.04	Feedback channel filter		1ms	10ms	○
F8.05	Target value digital setting	Universal drive mode setting range: 0.0~100.0% Water supply drive mode setting range: 0.0~F8.23	0.1% Or 0.1bar	0.0% Or 0.0bar	○
F8.06	Proportional gain Kp1	Set range: 0~1000	1	10	○
F8.07	Integration time Ti1	Set range: 1~10000ms	1ms	500ms	○
F8.08	Differential time Td1	Set range: 0~10000ms	1ms	0ms	○
F8.09	Proportional gain Kp2	F8.09 set range: 0~1000 F8.10 set range: 1~10000ms F8.11 set range: 0~10000ms	1	5	○
F8.10	Integration time Ti2		1ms	2000ms	○
F8.11	Differential time Td2		1ms	0ms	○
F8.12	Gain switching conditions	0: Do not switch 1: Switch through the DI terminal 2: Automatic switch based on the deviation 3: Switch automatically according to PID	1	0	○
F8.13	Gain switching threshold	Set range: 0.0~100.0%	0.1%	0.0%	○
F8.14	PID sampling period	Set range: 1~60000ms	1ms	1ms	○

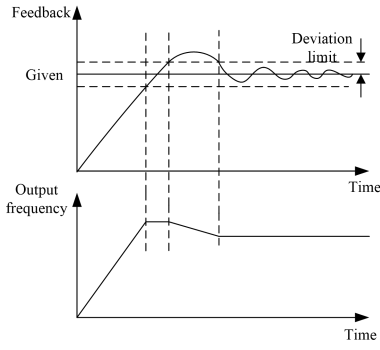
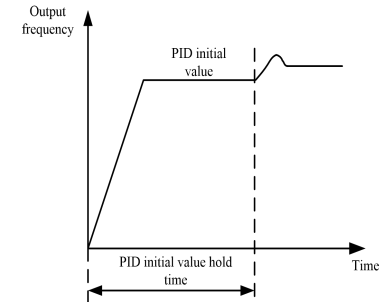
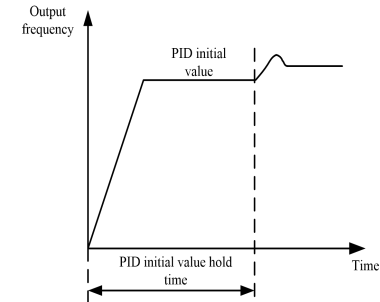
Parameter Code	Parameter Name	Parameter detailed description	Minimum Unit	Factory Value	Change
F8.15	Deviation limit	Set range: 0.0~50.0% 	0.1%	0.0%	○
F8.16	Closed-loop p regulation features	0: Positive action. 1: Negative action.	1	0	○
F8.17	PID initial value	F8.17 set range: 0.0~100.0% F8.18 set range: 0.00~600.00s 	0.1%	0.0%	×
F8.18	PID initial value hold time		0.01s	0.00s	×
F8.19	Closed-loop output polarity selection	0: Closed-loop output is negative, run at zero-frequency 1: Closed-loop output is negative, reverse	1	0	○
F8.20	PID reverse cutoff frequency	Set range: 0.00~upper limit frequency	0.01Hz	2.00Hz	×
F8.21	PID feedback loss detection value	F8.21 set range: 0.0~100.0% F8.22 set range: 0.0~200.0s (0.0s indicates no detection)	0.1%	10.0%	○
F8.22	PID feedback		0.1s	0.0s	○

Parameter Code	Parameter Name	Parameter detailed description	Minimum Unit	Factory Value	Change
	loss detection time				
F8.23	Maximum sensor range	Set range: 0.0~200.0bar	0.1bar	10.0bar	○
F8.24	Water supply sleep selection	0: Automatic sleep 1: Run at lower limit frequency	1	0	○
F8.25	Water supply sleep detection time	F8.25 set range: 0.0~3600.0s F8.26 set range: 0.01~600.00s	0.1s	2.0s	○
F8.26	Water supply sleep deceleration time		0.01s	30.00s	○
F8.27	Water supply wake pressure tolerance	F8.27 set range: 0.0~100.0% (100.0% is the set pressure value) F8.28 set range: 0.0~3600.0s	0.1%	10.0%	○
F8.28	Water supply wake detection time		0.1s	2.0s	○
F8.29	Water pressure overpressure alarm detection value	Set range: 0.0~100.0% (Do not test when set to 0, 100.0% is the maximum range of pressure sensor)	0.1%	90.0%	○
F8.30	Water pressure undervoltage alarm detection value	Set range: 0.0~100.0% (Do not test when set to 0, 100.0% is the maximum range of pressure sensor)	0.1%	0.0%	○
F8.31	Water pressure abnormal alarm detection time	Set range: 0.0~3600.0s	0.1s	50.0s	○
F8.32	Water shortage	F8.32 set range: 0.0~100.0% (100.0% is the set pressure value)	0.1%	0.0%	○

Parameter Code	Parameter Name	Parameter detailed description	Minimum Unit	Factory Value	Change								
	alarm set value	F8.33 set range: 0.0~3600.0s F8.34 set range: 0~10000min (0min indicate there's no water shortage restart function)											
F8.33	Water shortage alarm detection time		0.1s	20.0s	○								
F8.34	Water shortage restart wait time		1min	0min	○								
F8.35	Water supply absolute sleep detection time	Set range: 0~3600.0s	0.1s	10.0s	○								
F8.36	Delay time of pump reduction in shutdown	Set range: 2~240s	1s	2s	○								
F8.37	Add and reduce pump delay time	Set range: 1~36s	1s	5s	○								
F8.38	Add pump action frequency	Set range: Lower limit frequencyz~Upper limit frequency	0.01Hz	50.00Hz	×								
F8.39	Reduce pump operation frequency	Set range: Lower limit frequencyz~Upper limit frequency	0.01Hz	15.00Hz	×								
U0 water pump protection function 2													
U0.21	Pump working condition	Set range: 00000~11111 LED unit digit:Pump A status display LED ten digit:Pump B status display LED hundred digit:Pump C status display LED thousand digit:reserved LEDten-thousand digit:reserved 0:Non automatic control mode 1:automatic control mode	111	0	×								
		<table border="1" style="width: 100%; border-collapse: collapse;"> <tr> <td style="width: 25%;">Pump A</td> <td style="width: 25%;">Pump B</td> <td style="width: 25%;">Pump C</td> <td style="width: 25%;">U0.21</td> </tr> <tr> <td>Non-auto</td> <td>Non-auto</td> <td>Non-auto</td> <td>00000</td> </tr> </table>	Pump A	Pump B	Pump C	U0.21	Non-auto	Non-auto	Non-auto	00000			
Pump A	Pump B	Pump C	U0.21										
Non-auto	Non-auto	Non-auto	00000										

Parameter Code	Parameter Name	Parameter detailed description				Minimum Unit	Factory Value	Change
		Non-auto	Non-auto	Auto	00001			
		Non-auto	Auto	Non-auto	00010			
		Auto	Non-auto	Non-auto	00100			
		Non-auto	Auto	Auto	00011			
		Auto	Auto	Non-auto	00110			
		Auto	Non-auto	Auto	00101			
		Auto	Auto	Auto	00111			
				
<p>Note: If there is no display on the display bit, it indicates the normal shutdown state</p>								

Multi-function terminal DI

39	Pump A maintenance signal
40	Pump B maintenance signal
41	Pump C maintenance signal

The electrical wiring diagram is shown in the figure below:

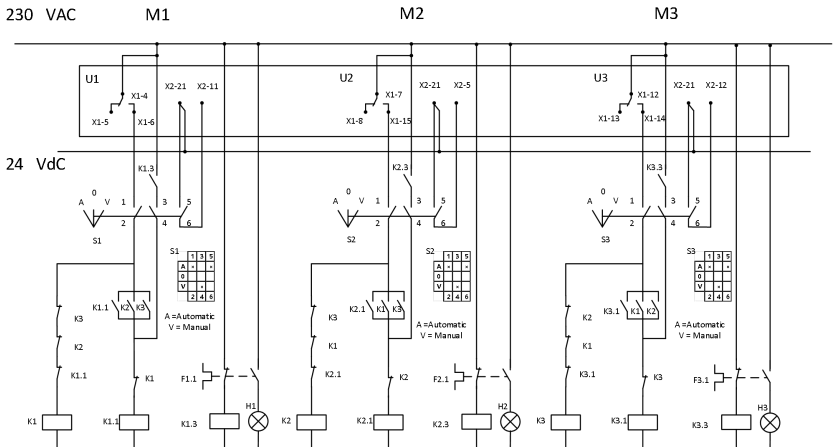

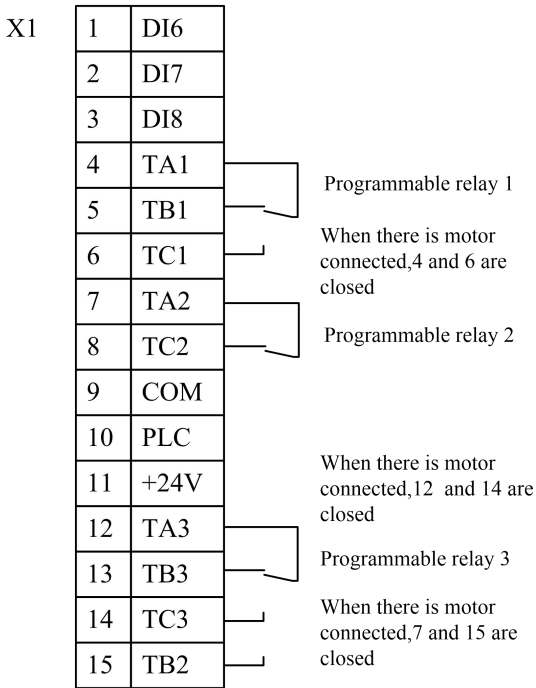

X2

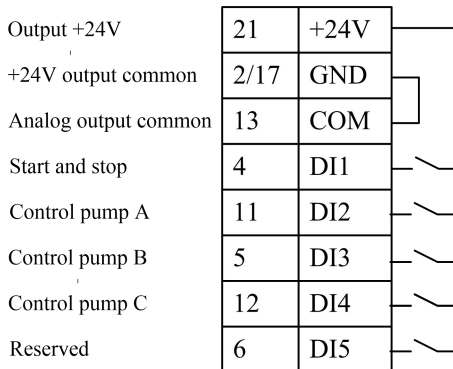

The sequence diagram of add/subtract pump signal control in automatic control mode is shown below:

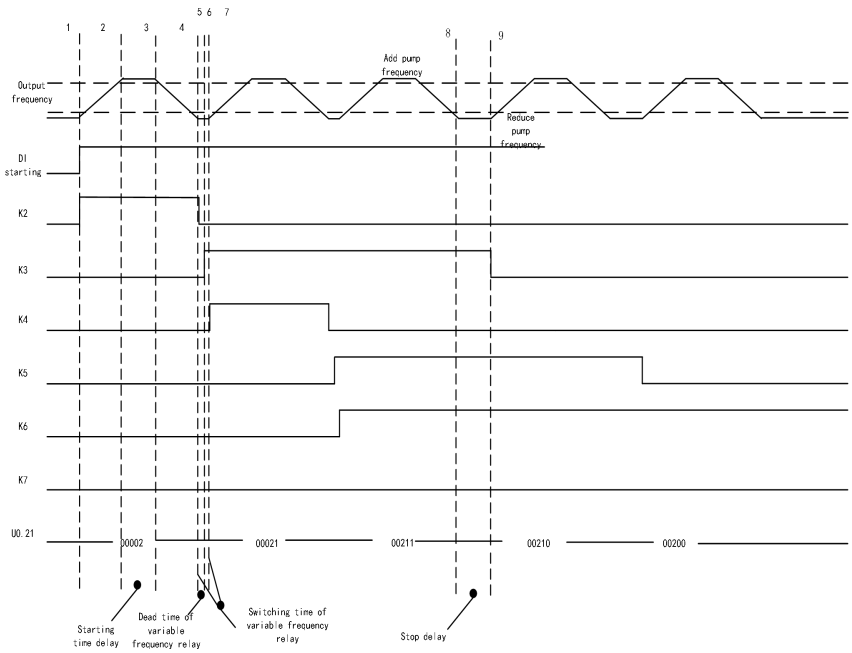

5.12 Troubleshooting

The HAV-SP series drive provides rich fault handling information. When the drive fails, the keypad will display the fault code and stop output. The fault record parameter group U1 can record the last 10 fault information. After the fault occurs, the processing steps are as follows:

1. When the drive fails, check whether the keypad display is abnormal? If yes, seek for service;
2. If there is no abnormality, please check the group U1 function code, confirm the corresponding fault record parameters, and determine the actual status at occurrence of the current fault through all parameters;
3. Check the fault alarm content and countermeasure table, and check whether there is a corresponding abnormal status according to the specific countermeasures?
4. Do troubleshooting or ask relevant personnel for help;
5. After confirming the troubleshooting, reset the fault and start running.

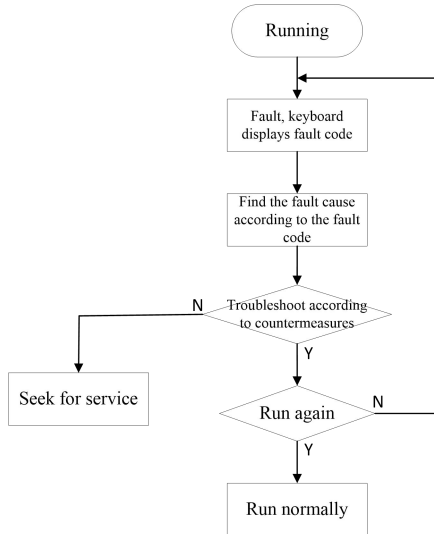

Related parameter table:

Parameter Code	Parameter name	Parameter detailed description	Factory value	Change
U1.00	Historical fault number	Set range: 0~9 According to the setting of this function code, you can view the fault record information of the last 10 times. By setting different values within U1.01~U1.06, the corresponding fault record will display.	0	○
U1.01	Fault code during fault	Fault record information at the xth fault (x is the set value of U1.00)	-	*
U1.02	Bus voltage during fault		-	*
U1.03	Output current during fault		-	*
U1.04	Running frequency during fault		-	*
U1.05	Running temperature during fault		-	*
U1.06	Fault occurrence time		-	*

Fault alarm content and countermeasure table:

Fault code	Fault type	Possible cause of failure	Countermeasures
E001	Drive accelerated	The acceleration time is	Extend the acceleration time

Fault code	Fault type	Possible cause of failure	Countermeasures
	running overcurrent	too short.	
		The V/F curve is improper.	Adjust the V/F curve setting, adjust the manual torque boost or set the motor parameters correctly to ensure that the automatic torque boost is normal.
		When an instant stop occurs, restart the motor in rotation.	Set the start mode F2.00 to speed tracking restart function.
		Low power grid voltage	Check the input power.
		The drive power is too small.	Use a drive with a large power level.
E002	Drive decelerated running overcurrent	The deceleration time is too short.	Extend the deceleration time.
		Load with potential energy or large inertia torque	Externally add a proper energy consumption braking component.
		The drive power is small.	Use a drive with a large power level.
E003	Drive constant-speed running overcurrent	Sudden change of load	Reduce the sudden change of load.
		The acceleration/deceleration time is set to short.	Extend the acceleration/deceleration time as appropriate.
		Abnormal load	Perform load check.
		Low power grid voltage	Check the input power.
		The drive power is small.	Use a drive with a large power level.
E004	Drive accelerated running overvoltage	Abnormal input voltage	Check the input power.
		The acceleration time is set to short.	Extend the acceleration time as appropriate.
		When an instant stop occurs, restart the motor in rotation.	Set the start mode F2.00 to speed tracking restart function.
E005	Drive decelerated running overvoltage	The deceleration time is too short (relative to regenerative energy).	Extend the deceleration time.
		Load with potential energy or large inertia torque	Select a proper energy consumption braking component.
E006	Drive constant-speed running overvoltage	Abnormal input voltage	Check the input power.
		The acceleration/deceleration time is set to short.	Extend the acceleration/deceleration time as appropriate.
		Abnormal change of the input voltage	Install an input reactor.

Fault code	Fault type	Possible cause of failure	Countermeasures
		Large load inertia	Consider using an energy-saving brake component.
E007	Undervoltage during running	Abnormal input voltage	Check the power voltage.
E008	Motor alarm overload	The V/F curve is improper.	Set the V/F curve and the torque boost correctly.
		Extremely low power grid voltage	Check the power grid voltage.
		The general motor operates for a long time at a low speed with a large load.	Special motor can be selected for long-term and low-speed operation.
		Incorrect motor rated current	Set the motor rated current correctly.
		Motor stalled or a large sudden change of load	Check the load.
E009	Drive alarm overload	The acceleration time is too short.	Extend the acceleration time
		Excessive DC braking capacity	Reduce the DC braking current, and extend the braking time.
		The V/F curve is improper.	Adjust the V/F curve and the torque boost.
		When an instant stop occurs, restart the motor in rotation.	Set the start mode F2.00 to speed tracking restart function.
		Extremely low power grid voltage	Check the power grid voltage.
		Excessive load	Select a drive with a larger power.
E010	Drive protection module	Instantaneous overcurrent of drive	See overcurrent countermeasures
		The output three phases have phase-to-phase short circuit Or grounded short circuit	Rewiring
		Blocked air duct or damaged fan	Clear the air duct or replace the fan
		Too high ambient temperature	Reduce the ambient temperature.
		Loose wire connection or plug-in of control board	Check and reconnect the wire
		Abnormal current waveform caused by output phase loss etc.	Check wiring
		Damaged auxiliary power supply, undervoltage of drive	Seek for service.

Fault code	Fault type	Possible cause of failure	Countermeasures
		Drive module arm straight-through	Seek for service.
		Abnormal control board	Seek for service.
E011	Phase loss alarm at input side	Phase loss of input R, S, and T	Check the installation wiring Check the input voltage
E012	Phase loss alarm at output side	Phase loss of output U, V, and W	Check the output wiring. Check the motor and the cable.
E013	Drive module radiator alarm overheat	Too high ambient temperature	Reduce the ambient temperature.
		Blocked air duct	Clear the air duct.
		Damaged fan	Replace the fan.
		Abnormal drive module	Seek for service.
E014	Rectifier module radiator alarm overheat	Too high ambient temperature	Reduce the ambient temperature.
		Blocked air duct	Clear the air duct.
		Damaged fan	Replace the fan.
E015	External fault alarm	External fault emergency stop terminal closed	Check the external equipment input.
E016	485 communication error alarm	Improper baud rate setting	Set the baud rate properly.
		Serial port communication error	Press the stop key to reset, and seek for service.
		Improper fault alarm parameter setting	Modify the settings of Fb.04, Fb.03 and FA.07.
		The host computer doesn't work.	Check whether the host computer works or not, and whether the wiring is correct.
E017	Current detection circuit fault alarm	Damaged auxiliary power supply	Seek for service.
		Damaged Hall device	Seek for service.
		Abnormal amplification circuit	Seek for service.
E018	Reserved	-	-
E019	Reserved	-	-
E020	Closed-loop feedback loss alarm	Feedback circuit disconnected	Check the feedback circuit.
E021	Water pressure overpressure alarm	Abnormal sensor feedback signal	Check the sensor wiring.
		Too low overvoltage alarm value	Modify the F8.29 setting.
		Too short alarm	Modify the F8.31 setting.

Fault code	Fault type	Possible cause of failure	Countermeasures
		detection time	
E022	Reserved	-	-
E023	Water shortage alarm	Abnormal water pressure/water level	Check whether the water pressure at the pump inlet is abnormal.
		Broken line or poor contact of the sensor, system has no feedback signal	Check the sensor installation and wiring.
		Too high water shortage alarm value.	Modify the F8.32 setting.
		Too short water shortage detection time	Modify the F8.33 setting.
E024	Reserved	-	-
E025	Reserved	-	-
E026	Abnormal circuit buffer	Extremely low power grid voltage	Check the power grid voltage
		Damaged thyristor	Replace the main circuit contactor and seek for service
		Damaged power-on buffer resistance	Replace buffer resistance and seek for service
		Damaged control circuit	Seek for service.
		Input phase loss	Check the input R, S, T wiring

Fault code	Fault type	Possible cause of failure	Countermeasures
E027	Reserved	-	-
E028	Keypad parameter copy error alarm	The keypad parameters are incomplete.	Re-upload the parameters in the backup keypad.
		The keypad parameters are inconsistent with the main control board parameter software version.	The parameter software version is inconsistent, and you cannot execute the parameter downloading, please re-upload the parameters in the backup keypad.
		The keypad parameters are of 2S model, but the main control board parameters are of 4T model.	The parameter rated voltage is inconsistent so the parameter download function cannot be executed. Re-upload and download the parameters from the keypad.
		The keypad parameters and the main control board parameters are inconsistent with the drive's model.	Drive's model is inconsistent so the parameter download function cannot be executed. Re-upload and download the parameters from the keypad.
E029	Wave-by-wave current limiting alarm	Excessive load	Check whether the grid voltage is normal
			Check whether the motor is locked
			Seek for service.
E034	Water pipe break alarm	Water pipe break	Check the pipe

Appendix I Communication Protocol

Networking mode

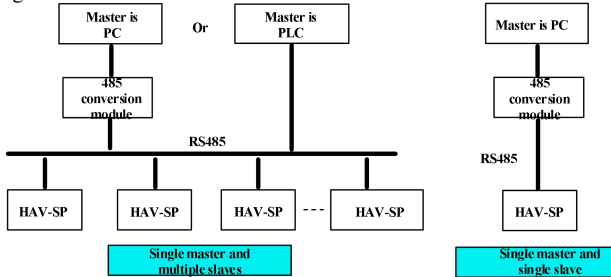

Figure 1: Schematic Diagram of Drive RS485 Networking Mode

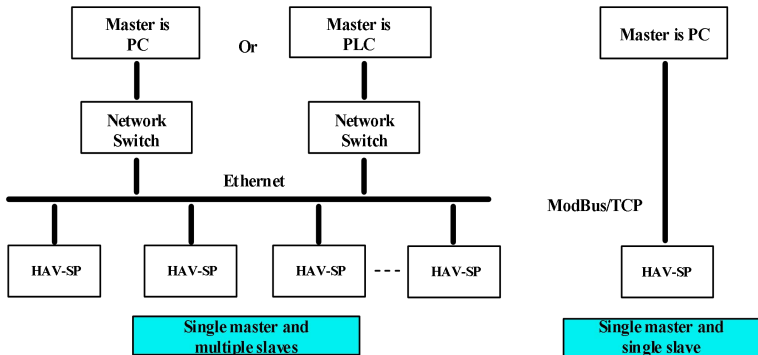

Figure 2: Schematic Diagram of Drive Ethernet Networking Mode

The interface way:

RS485, Asynchronous half duplex. Default: 8-N-2, 9600bps. See Fb group description for parameter Settings.

Ethernet, full duplex. Default: IP address 192.168.1.30, Subnet mask 255.255.255.0, Gateway 192.168.1.1. See Fb group description for parameter Settings.

Protocol format:

Modbus supports TCP, RTU, and ASCII modes. The corresponding frame formats are as follows:

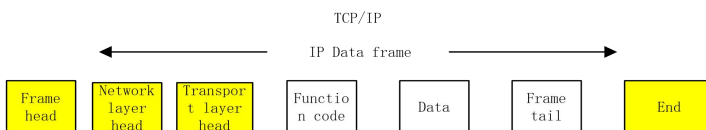

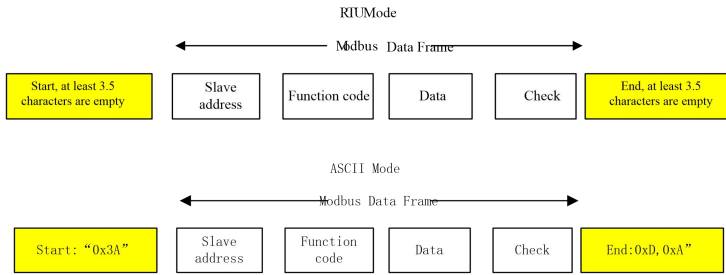

Protocol function:

The main function of Modbus is to read and write parameters. Different function codes determine different operation requests. The drive Modbus protocol supports the following function code operations:

Function code	Function code significance
0x03	Read drive function code parameter and running status parameter
0x06	Rewrite function code or control parameter of single drive
0x10	Rewrite function code or control parameter of multiple drives

The function code parameter, control parameter and status parameter of the drive are mapped as Modbus read-write registers. The read-write characteristics and range of the function code parameters follow the instructions in the drive user manual. The group number of the drive function code is mapped to the high byte address of the register, and the index in the group is mapped to the low byte address of the register. The control parameter of the drive is virtualized to the drive function code group 18, and the status parameter of the drive is virtualized to the drive function code group 19. The correspondence between the function code group number and the high byte of its mapped register address is as follows:

Group F0: 0x00; group F1: 0x01; group F2: 0x02; group F3: 0x03; group F4: 0x04; group F5: 0x05; group F6: 0x06; group F7: 0x07; group F8: 0x08; group F9: 0x09; FA group: 0x0A; Fb group: 0x0B; FC group: 0x0C; Fd group: 0x0D; FE group: 0x0E; FF group: 0x0F; U0 group: 0x10; U1 group: 0x11; drive control parameter group: 0x12; drive status parameter group: 0x13.

For example, the register address of the drive function code parameter F3.02 is 0x0302, and the register address of the drive function code parameter FE.01 is 0x0E01.

If the operation request fails, the response is an error code and an exception code. The error code is equal to (function code + 0x80), and the exception code indicates the error reason. The exception code is listed as follows:

Exception code	Exception code significance
0x1	Illegal function code.
0x2	Illegal register address.
0x3	Data error, that is, the data exceeds the upper or lower limit.
0x4	Slave operation failed (including errors caused by invalid data, although the data is within the upper and lower limits).
0x18	Information frame error: Including information length error and check error.
0x20	Parameters cannot be modified.
0x21	Out of the range of function group.

The drive control parameters can complete functions to start, stop, and set running frequency of the drive. By searching drive status parameters, parameters such as operating frequency, output

current, and output torque of the drive can be obtained. The specific drive control parameters and status parameters are enumerated as follows (except 0x1207 virtual output terminal is read-only, other parameters are readable and writable):

HAV-SP drive control parameter index

Register address	Parameter name	Whether save after power failure
0x1200	Control command word 1	No
0x1201	Main frequency setting	Yes
0x1202	Reserved	-
0x1203	PID input	Yes
0x1204	PID feedback	Yes
0x1205	Analog output AO, high-speed DO2 setting	No
0x1206	Virtual input terminal: Define by bit: BIT0~9 = VDI1~VDI10, BIT10~15 = Reserved	No
0x1207	Virtual output terminals (read-only): Define by bit: BIT0~4 = VDO1~VDO5, BIT5~15 = Reserved	No
0x2000	Control command word 2	No
0x2001	Main frequency setting	Yes

HAV-SP drive status parameter index

Register address	Parameter name
0x1300	Running status word
0x1301	Drive model
0x1326	error code

The drive control word 1 (register address 0x1200) bit is defined as follows:

Control word (bit)	Value	Significance	Function description
Bit2, 1, 0	111B	Run command	Start the drive
	110B	Stop command	Stop according to the way set by function code F2.08
	Remainin g	No command	
Bit3	1	Reverse	Set the running direction when the run command is valid (invalid for jog command)
	0	Forward	
Bit8~Bit4	0	Reserved	-
Bit9	1	Fault reset valid	
	0	Fault reset invalid	
Bit15~Bit5	0	Reserved	-

The drive control word 2 (register address 0x2000) bit is defined as follows:

Control word (bit)	Value	Significance	Function description
Bit1, 0	00B	No function	Stop according to the way set by function code F2.08
	01B	Stop	

	10B	Start	Start the drive
	11B	No function	
Bit3, 2	0	Reserved	-
Bit5, 4	00B	No function	
	01B	Forward instruction	
	10B	Reverse instruction	
	11B	Fault reset	
Bit15~Bit5	0	Reserved	-

The drive status word (register address 0x1300) bit is defined as follows:

Status word (bit)	Value	Significance	Remarks
Bit0	1	Drive operation	
	0	Drive stop	
Bit1	1	Drive reverse	
	0	Drive forward	
Bit2	1	Reach the main setting	
	0	Not reach the main setting	
Bit7~Bit3	0	Reserved	
Bit15~Bit8	00~0xFF	Fault code	0: Indicates the drive is normal; Not 0: Indicates a fault, and refer to the user manual of the drive of relevant type for detailed fault code significance. For example, the fault code for motor overload E008 is 0x08, and for undervoltage is 0x1F.

Application example

The command to start the 1# drive to run in the forward direction and set the speed to 50.00HZ (internally indicated as 5000) is as follows:

	Address	Function code	Register address	Register number	Register content bytes	Register content	Verification code
Request	0x01	0x10	0x1200	0x0002	0x04	0x0007, 0x1388	0x9B98
Response	0x01	0x10	0x1200	0x0002	None	None	0x44B0

5# drive fault reset:

Address	Function code	Register address	Register content	Verification code
0x05	0x06	0x1200	0x0200	0x8C56
0x05	0x06	0x1200	0x0200	0x8C56

Read the running frequency of the 4# drive, and the drive response running frequency is 50.00HZ:

Address	Function code	Register address	Register number or read bytes	Register content	Verification code
---------	---------------	------------------	-------------------------------	------------------	-------------------

0x04	0x03	0x1000	0x0001	None	0x809F
0x04	0x03	None	0x02	0x1388	0x7912

Write the acceleration time 1 (i.e. function code F1.11) of 5# drive to 1.00s, and do not save after power failure.

Address	Function code	Register address	Register content	Verification code
0x05	0x06	0x010B	0x0064	0xF99B
0x05	0x06	0x010B	0x0064	0XF99B

Read the output current of 5# drive, and the drive response output current is 3.00A.

Address	Function code	Register address	Register number or read bytes	Register content	Verification code
0x05	0x03	0x1002	0x0001	None	0x208E
0x05	0x03	None	0x02	0x012C	0x49C9

Calibration relationship of the drive

A) The calibration of the frequency is 1:100

To make the drive run at 50Hz, the main setting shall be 0x1388 (5000).

B) The calibration of the time is 1:100

To make the drive acceleration time be 3s, the function code setting shall be 0x012C (300).

C) The calibration of the current is 1:100

If the drive feedback current is 0x012C (300), the current of the drive is 3A.

Appendix II Multi-pump control expansion card applications

6.1 Multi-pump control expansion card installation instructions

The realization of multi-pump control function requires the addition of HAVSPIO3DI3R expansion card. HAVSPIO3DI3R expansion card is a multi-functional IO expansion card designed for HAV-SP series drive. The installation position is shown in the following figure.

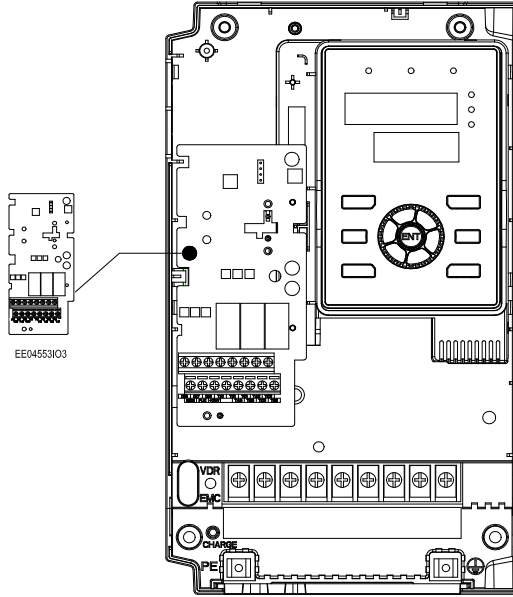

Figure 6-1 HAVSPIO3DI3R expansion card installation diagram

6.2 Multi-pump control expansion card terminal function description

HAVSPIO3DI3R expansion card can expand 3 DI input, 3 relay output, mainly designed for HAV-SP water supply drive multi-pump control mode;

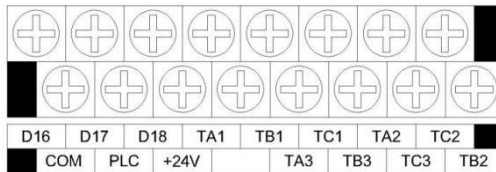

Figure 6-2 Terminals on the HAVSPIO3DI3R expansion card

Table 6-1 Functions of terminals on the HAVSPIO3DI3R expansion card

Category	Terminal label	Name	Terminal Function description	Specification
Relay output terminal	TA1 TB1 TC1	Programmable relay terminal output	When not action: TA-TB normally closed; TA-TC normally open; When action : TA-TB normally open; TA-TC normally closed (See note F6.13 for details)	Contact rating NO: 5A 250VAC NC: 3A 250VAC
	TA2 TB2 TC2	Programmable relay terminal output	When not action: TA-TB normally closed; TA-TC normally open; When action : TA-TB normally open; TA-TC normally closed (See note F6.13 for details)	Contact rating NO: 5A 250VAC NC: 3A 250VAC
	TA3 TB3 TC3	Programmable relay terminal output	When not action: TA-TB normally closed; TA-TC normally open; When action : TA-TB normally open; TA-TC normally closed (See note F6.13 for details)	Contact rating NO: 5A 250VAC NC: 3A 250VAC
Multi-function input terminal	DI6	Multi-function input terminal 6	Programmable definition: switching input terminal of various functions. See chapter 4 Terminal Function Parameters (Switching Input and Output): input terminal function description.(public side: COM) (See F6.05-6.08)	
	DI7	Multi-function input terminal 7		
	DI8	Multi-function input terminal 8		
Power	+24V	+24V power supply	Digital signal power supply	Maximum output current:200mA
	COM	+24V power public side	Digital signal input and public side output	
	PLC	Multi-function input public side	Public side DI6—DI8	With 24V short circuit

6.3 Fault countermeasures and exception handling

Fault code	Fault types	Possible fault causes	Countermeasures
E020	Closed loop feedback loss alarm	Feedback line disconnection	Check the feedback line
E021	Water pressure overpressure alarm	The sensor feedback signal is abnormal	Connection of detection sensor
		The overpressure alarm	Modify F8.29 settings

		was set too low	
		Alarm detection time is too short	Modify F8.31 settings
E023	Water pipe water shortage alarm	Abnormal water pressure/water level	Check whether the inlet water pressure of the water pump is abnormal
		Sensor disconnection or poor contact, no feedback signal in the system	Check the sensor installation and cable connection
		Water shortage alarm set too high	Modify F8.32 settings
		Water shortage detection time is too short	Modify F8.33 settings
E024	Water tank water alarm	Abnormal water pressure/water level	Check whether the inlet water pressure of the water pump is abnormal
		Sensor disconnection or poor contact, no feedback signal in the system	Check the sensor installation and cable connection
		Water shortage alarm set too high	Modify FE.17 settings
E034	Water pipe break alarm	The sensor feedback signal is abnormal	Connection of detection sensor
		The water pipe break alarm value is too high	Modify FE.18 settings
		Alarm detection time is too short	Modify FE.19 settings
E035	Maintenance variable frequency pump alarm	Variable frequency pump is currently being repaired	After confirming the overhaul of the variable frequency pump, set the F4.10 bit to 0

Warranty Agreement

1. The warranty covers only the drive itself.
2. During normal use, if the drive fails or is damaged within 18 months, the company shall be responsible for repairing; If above 18 months, a reasonable maintenance fee will be charged.
3. The start of the warranty period is the date of manufacture of our company.
4. Within 18 months, a certain maintenance fee shall also be charged if:
 - Unable to follow the operation steps in the user manual causing damages to the drive.
 - The drive is damaged due to flood, fire, abnormal voltage, etc.
 - The drive is damaged due to incorrect wiring, etc.
 - Damages caused by using the drive for abnormal functions.
5. The related service fee is calculated based on actual

Drive warranty form

User unit:	
Detailed address:	
Zip code:	Contact person:
Telephone number:	Fax:
Machine number:	
Power:	Model:
Contract number:	Date of purchase:
Service unit:	
Contact person:	Telephone number:
Repairman:	Telephone number:
Date of repair:	
User comments and evaluation: <input type="checkbox"/> Excellent <input type="checkbox"/> Good <input type="checkbox"/> Normal <input type="checkbox"/> Poor	
Other comments:	
User signature:	Day Month Year
Company return visit records:	
Others:	

Certificate of Conformity

Inspector _____

This product is qualified via inspection and is allowed to leave the factory.