

Preface

Thank you for purchasing the Basic and Smart solar series drive developed and produced by Himel

The Basic series drive is a universal high-performance drive with advanced control performance such as large low-frequency torque, self-identification of motor parameters, and optimal acceleration and deceleration control; it has functions to meet different process requirements, such as multi-step control and simple PLC control , PI control, fixed-length control, droop control, automatic energy-saving operation, flexible frequency setting method, diversified frequency combination methods and combination algorithms, and other practical functions. It can be used to drive machine tools, cables, textiles, papermaking, food, packaging, chemicals, municipal engineering and other automated production equipment to meet the performance and function requirements of different industrial equipment.

Before using this drive, the users and relevant technicians shall read this manual carefully to ensure that the drive can be properly installed and operated, so that the drive can perform its best performance.

If there is any change to this user manual, please refer to the new version without notice.

High-performance Drive
User Manual

Version: V1.1

This product implements standards:

The design and production of this product refer to the latest national standards (GB or GB/T), International Electrotechnical Commission Standards (IEC) and International System of Units (SI). The technical parameters of the relevant parts can meet the requirements of national standards (GB or GB/T) and International Electrotechnical Commission Standards (IEC). Main standards:

GB/T 12668.2-2002 Adjustable Speed Electrical Power Drive Systems - Part 2: General Requirements - Rating Specifications for Low Voltage Adjustable Frequency AC Power Drive Systems

GB 12668.3-2012 Adjustable Speed Electrical Power Drive Systems - Part 3: EMC Requirements and Specific Test Methods

GB 12668.501-2013 Adjustable Speed Electrical Power Drive Systems - Part 5: Safety Requirements - Electrical, Thermal and Energy

GB/T 2423.1-2008 Environmental Testing for Electric and Electronic Products - Part 1: Test Methods Tests A: Cold

GB/T 2423.2-2008 Environmental Testing for Electric and Electronic Products - Part 2: Test Methods Tests B: Dry Heat

GB/T 2423.3-2016 Environmental Testing - Part 2: Testing Method - Test Cab: Damp Test, Steady State

GB/T 2423.4-2008 Environmental Testing for Electric and Electronic Products - Part 2: Test method - Test Db: Damp heat, cyclic (12h+12h Cycle)

GB/T 2423.22-2012 Environmental Testing - Part 2: Test Methods - Test N: Change of Temperature

GB/T 2423.7-2018 Environmental Testing - Part 2: Test Methods - Test Ec: Rough Handling Shocks, Primarily for Equipment-type Specimens

GB/T4798.1-2005 Environmental Conditions Existing in the Application of Electric and Electronic Products Section 1: Storage

GB/T4798.2-2008 Environmental Conditions Existing in the Application of Electric and Electronic Products - Part 2: Transportation

GB/T4798.3-2007 Environmental Conditions Existing in the Application of Electric and Electronic Products - Part 3: Stationary Use at Weather-protected Locations

Danger

The drive must be reliably grounded. If the drive is not reliably grounded, there may be a potential danger of personal injury in the device.

Readers

This user manual is suitable for the following readers.

Drive installers, engineering technicians (electrical engineers, electrical operators, etc.), designers, etc. Please ensure that this user manual reaches the end users.

Notational conventions in this manual



Caution: Moderate or minor injuries may occur due to failure to operate as required.



Danger: Deaths or serious injuries may occur due to failure to operate as required.

Table of Contents

Chapter I Product Specification and Ordering Instructions	1
1.1 Drive series models.....	1
1.2 Product appearance and installation dimensions.....	2
1.3 Optional parts.....	3
1.4 Braking resistors.....	5
Chapter II Installation and Wiring of Drive.....	8
2.1 Drive installation environment.....	8
2.2. Removal and installation of drive panel.....	11
2.3 Standard wiring diagram.....	13
2.4 Control circuit configuration and wiring.....	17
Chapter III Operation Instructions of Drive.....	23
3.1 Key function description.....	23
3.2 Keypad operation methods.....	24
Chapter IV Function Parameter Table.....	28
4.1 Function parameter table.....	28
4.2 Monitoring parameter group U0.....	86
4.3 Fault record parameter group U1.....	90
4.4 Fault code table.....	91
Appendix I Communication Protocol.....	92
Drive Warranty Form.....	103

Chapter I Product Specification and Ordering Instructions

1.1 Drive series models

This drive has two voltage levels of 220V and 380V. The applicable motor power range is: 380V: 0.4kW-5.5kW; 220V: 0.4kW-2.2kW. The models of this series drives are shown in Table 1-1.

Table 1-1 Drive Models

Drive model (G: Constant torque load)		Rated capacity (kVA)	Rated output current (A)	Adaptable motor (kW)
220V single phase	HAV-BA/SS-2S0004G	0.75	2.4	0.4
	HAV-BA/SS-2S0007G	1.5	4.5	0.75
	HAV-BA/SS-2S0015G	2.7	7.1	1.5
	HAV-BA/SS-2S0022G	3.7	9.8	2.2
220V three-phase	HAV-BA/SS-2T0022G	3.7	9.8	2.2
380V three-phase	HAV-BA/SS-4T0004G	0.75	1.5	0.4
	HAV-BA/SS-4T0007G	1.5	2.3	0.75
	HAV-BA/SS-4T0015G	2.7	3.7	1.5
	HAV-BA/SS-4T0022G	3.7	5.0	2.2
	HAV-BA/SS-4T0040G	7.5	8.8	4.0
	HAV-BA/SS-4T0055G	9.0	13.0	5.5

 **Note:** For other power stage models of 220V voltage level, please consult the manufacturer before ordering.

1.2 Product appearance and installation dimensions

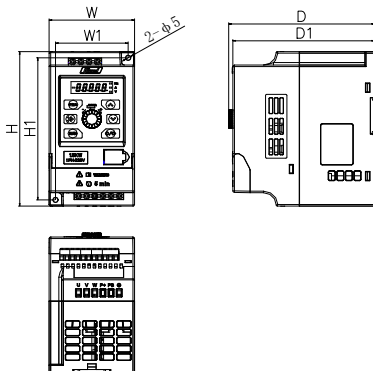

(a) Specifications

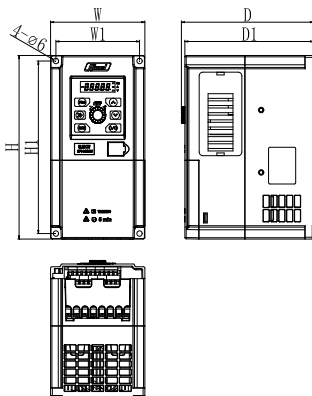

(b) Specifications

Table 1-2 Drive Appearance and Installation Dimensions
(Unit: mm)

Specification	W	W1	H	H1	D	D1	Mounting hole diameter (Φ)	Reference diagram
HAV-BA/SS-4T0004G	80	68	150	138	136.5	133	5	(a)
HAV-BA/SS-2S0004G								
HAV-BA/SS-4T0007G								
HAV-BA/SS-2S0007G								
HAV-BA/SS-4T0015G								
HAV-BA/SS-2S0015G								
HAV-BA/SS-4T0022G								
HAV-BA/SS-4T0055G	106	94	200	188	148.5	144.6	6	(b)
HAV-BA/SS-4T0040G								
HAV-BA/SS-2S0022G								
HAV-BA/SS-2T0022G								

1.3 Optional parts

1.3.1 Remote control Keypad

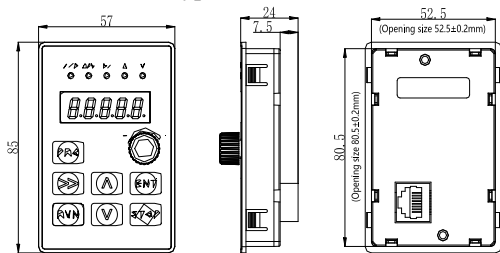

Figure 1-1 Remote Control Keypad 1 (HAV-BA-LKD)

Note: The standard available lengths of optional network cables are 2m and 5m. If you need network cables of other specifications, please order separately.

1.3.2 Dustproof sticker (cover plate)



Figure 1-2 Dustproof Sticker

Table 1-3 Dustproof Sticker Table

Dustproof sticker model	Adaptable models
HAV-BA-4T0022	HAV-BA/SS-4T0004G, HAV-BA/SS-2S0004G, HAV-BA/SS-4T0007G, HAV-BA/SS-2S0007G, HAV-BA/SS-4T0015G, HAV-BA/SS-2S0015G, HAV-BA/SS-4T0022G

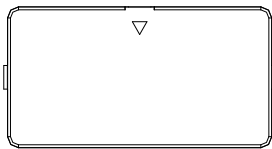

Figure 1-3 Dustproof Cover Plate

Table 1-4 Dustproof Cover Plate Table

Dustproof cover plate model	Adaptable models
HAV-BA-4T0040 (black)	HAV-BA/SS-4T0055G, HAV-BA/SS-4T0040G, HAV-BA/SS-2S0022G, HAV-BA/SS-2T0022G

1.4 Braking resistors

Please select energy consumption braking resistors according to Table 1-5 and Table 1-6. The wiring of the braking resistors is shown in Figure 1-4.

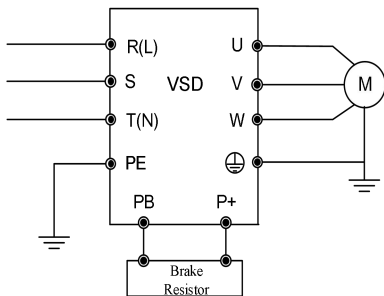

Figure 1-4 Drive and Braking Resistor Connection Diagram

Note:

1. The power derating of the braking resistor shall not exceed 30%, otherwise there is a risk of fire;
2. The length of the wire for braking resistor shall be less than 5m.
During the braking process, the braking resistor will cause

temperature rise due to energy consumption. During installation, pay attention to safety protection and sound ventilation.

The braking resistor resistance and the power are selected according to the actual situation. The greater the system inertia, the shorter the deceleration time required, the more frequent the braking, the greater the power required by the braking resistor and the smaller the resistance required. Table 1-5 and Table 1-6 are recommended based on general applications (braking usage rate is 10%).

Table 1-5 Braking Resistor Selection Table (380V Voltage Level)

Specification	Suitable motor power (kW)	Braking resistor recommended Resistance (Ω)	Braking resistor recommended Power (W)
HAV-BA/SS-4T0004G	0.4	≥ 750	75
HAV-BA/SS-4T0007G	0.75	≥ 500	100
HAV-BA/SS-4T0015G	1.5	≥ 300	200
HAV-BA/SS-4T0022G	2.2	≥ 200	200
HAV-BA/SS-4T0040G	4.0	≥ 200	300
HAV-BA/SS-4T0055G	5.5	≥ 80	750

Table 1-6 Braking Resistor Selection Table (220V Voltage Level)

Specification	Suitable motor power (kW)	Braking resistor recommended Resistance (Ω)	Braking resistor recommended Power (W)
HAV-BA/SS-2S0004G	0.4	≥ 200	75
HAV-BA/SS-2S0007G	0.75	≥ 150	100

Chapter I Product Specification and Ordering Instructions

HAV-BA/SS-2S0015G	1.5	≥ 100	200
HAV-BA/SS-2S0022G	2.2	≥ 75	300
HAV-BA/SS-2T0022G	2.2	≥ 75	300

Chapter II Installation and Wiring of Drive

2.1 Drive installation environment

2.1.1 Installation environment requirements

- (1) Install in a well-ventilated indoor place. The ambient temperature is required to be within the range of -10°C - 40°C . If the temperature exceeds 40°C , external forced cooling or derating is required.
- (2) Avoid installing in places with direct sunlight, dusty, floating fibers and metal powder.
- (3) Do not install in places with corrosive or explosive gases.
- (4) The humidity is required to be lower than 90%RH, without condensation of water droplets.
- (5) Install in places where the plane fixed vibration is less than 5.9 m/s^2 .
- (6) Try to keep away from electromagnetic interference sources and other electronic instruments and equipment that are sensitive to electromagnetic interference.

2.1.2 Installation direction and space

- (1) Generally, vertical installation shall be adopted.
- (2) Minimum installation gaps and distances are shown in Figure 2-1.
- (3) When multiple drives are installed up and down, the BA/SSffle applied in the middle is shown in Figure 2-2.

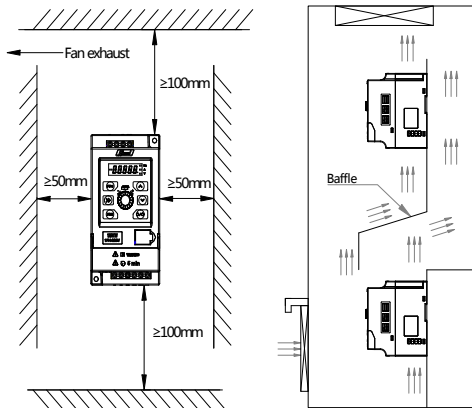

Figure 2-1 Installation Gap Diagram Figure 2-2 Installation Diagram of Multiple Drives

2.1.3 Mechanical installation methods and steps(wall-mounted installation and guide rail installation are supported)

1. Wall-mounted screw installation

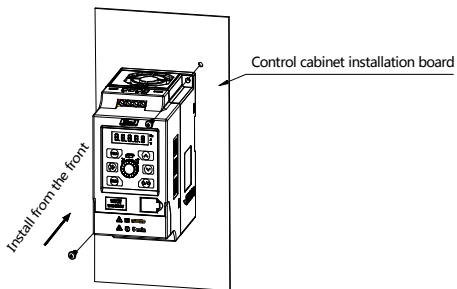

Figure 2-3 Wall-mounted Installation Diagram

2. Guide rail installation

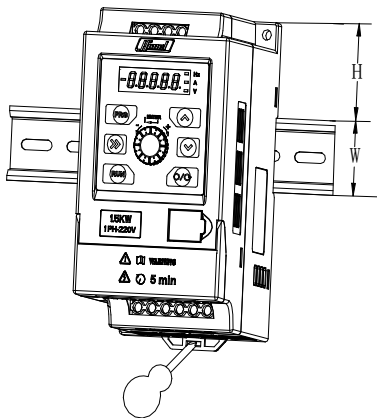

Figure 2-4 Guide Rail Installation Diagram

- (1) Use a slotted screwdriver to insert into the slide block groove at the bottom, to move the slide block out;
- (2) Install the machine onto the guide rail support, push the guide rail slide block up to the original place and clamp.

Note: H is 45mm, W is 35mm

Table 2-1 Guide Rail Installation Table

Specification	Whether supported
HAV-BA/SS-4T0004G	Supported
HAV-BA/SS-2S0004G	
HAV-BA/SS-4T0007G	
HAV-BA/SS-2S0007G	
HAV-BA/SS-4T0015G	
HAV-BA/SS-2S0015G	
HAV-BA/SS-4T0022G	
HAV-BA/SS-4T0055G	Not supported
HAV-BA/SS-4T0040G	
HAV-BA/SS-2S0022G	
HAV-BA/SS-2T0022G	

2.2. Removal and installation of keypad

1. RJ45 flip shell

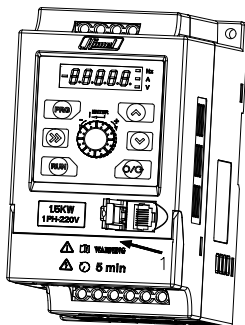

Figure 2-5 RJ45 Flip Shell's Open-Connect External Keypad

2. Wiring flip shell

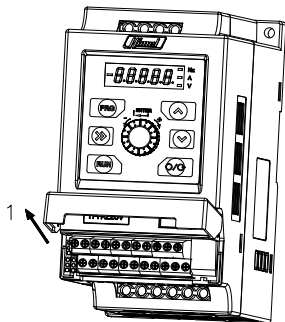

Figure 2-6 Wiring Flip Shell's Open-Control Terminal Wiring

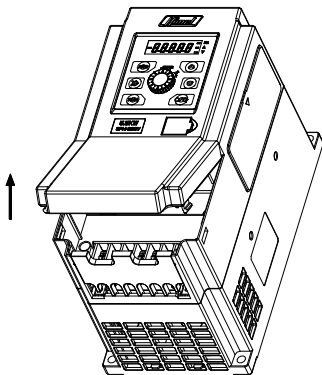
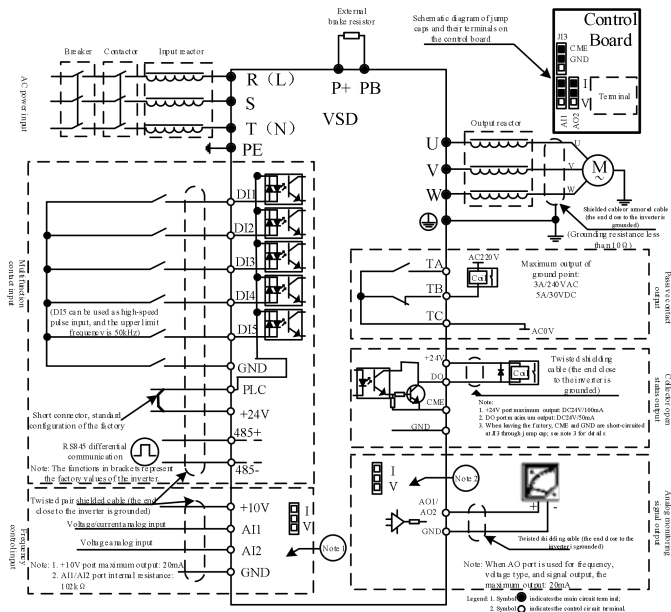

Figure 2-7 Wiring Flip Shell's Open-Control Terminal Wiring

2.3 Standard wiring diagram



Note 1: The AI1 port can receive both voltage signals and current signals; AI1 (three-PIN needle on corresponding control board, the bottom left one is for AI1) in the corresponding wiring diagram (as shown in the upper right corner of the above figure); short the middle and the upper pin for current signal input; short the middle and bottom pin for voltage signal input; the AI2 port can only receive voltage signals.





Note 2: The AO2 port can output both voltage signals and current signals; AO2 (three-PIN needle on corresponding control board, the bottom right one is for AO2) in the corresponding wiring diagram (as shown in the upper right corner of the above figure); short the middle and the upper pin for current signal input; short the middle and bottom pin for voltage signal input; the AO1 port can only output voltage signals.

Note 3: The standard factory configuration of CME and GND is that the middle pin of J13 is short-circuited to its upper pin (under standard factory configuration, DO port uses the internal +24V as the pull-up power supply, and its ground system is drive GND), that is, CME is short circuited to GND; when GND interfaces are insufficient, the CME interfaces can be used as GND interfaces;

When DO port uses the external +24V power supply as pull-up (DO port is pulled up to +24V through 4.7K resistance), just remove the jump cap of J13 port (just place the short-circuited cap to the J13 middle pin and the lower pin, to avoid losing jump cap), in this case, CME is short-circuited to the ground system of external +24V power supply.

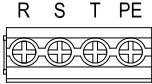
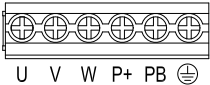
2.3.1 Wiring of main circuit terminals

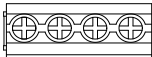
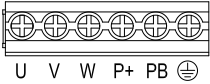
(1) The main circuit input and output terminals are shown in Table 2-2.

Applicable models	Main circuit terminals	Terminal name	Function description
HAV-BA/SS-4T0004G HAV-BA/SS-4T0007G HAV-BA/SS-4T0015G HAV-BA/SS-4T0022G		R, S, T	Three-phase AC 380V input terminal
		PE	Protective ground terminal
		U, V, W	Three-phase AC output terminal
P+, PB		Braking resistor wiring terminal	
		Motor ground terminal	
HAV-BA/SS-2S0004G HAV-BA/SS-2S0007G HAV-BA/SS-2S0015G		L, N	Single-phase AC input terminal
		PE	Protective ground terminal
		U, V, W	Three-phase AC output terminal
P+, PB		Braking resistor wiring terminal	
		Motor ground terminal	

Applicable models	Main circuit terminals	Terminal name	Function description
HAV-BA/SS-4T0040G HAV-BA/SS-4T0055G HAV-BA/SS-2T0022G		R, S, T	Three-phase AC 380V input terminal
		U, V, W	Three-phase AC output terminal
		P+, PB	Braking resistor wiring terminal
		PE	Protective ground terminal
			Motor ground terminal
HAV-BA/SS-2S0022G		L, N	Single-phase AC input terminal
		U, V, W	Three-phase AC output terminal
		P+, PB	Braking resistor wiring terminal
		PE	Protective ground terminal
			Motor ground terminal

(2) The selection of main circuit cable diameter and protection circuit breaker QF or fuse at VSD input in show in Table 2-3:

Specification	Circuit breaker (A)	Fuse (A)	Recommended input and output power wires(mm ²)	Control wire (mm ²)
HAV-BA/SS-4T0004G	10	10	1.5	1
HAV-BA/SS-2S0004G	10	10	1.5	1
HAV-BA/SS-4T0007G	10	10	1.5	1
HAV-BA/SS-2S0007G	10	10	1.5	1
HAV-BA/SS-4T0015G	10	10	1.5	1
HAV-BA/SS-2S0015G	20	16	2.5	1
HAV-BA/SS-4T0022G	16	10	2.5	1
HAV-BA/SS-4T0040G	20	16	2.5	1
HAV-BA/SS-4T0055G	25	25	4.0	1

2.4 Control circuit configuration and wiring

2.4.1 Control circuit terminal arrangement is as follows

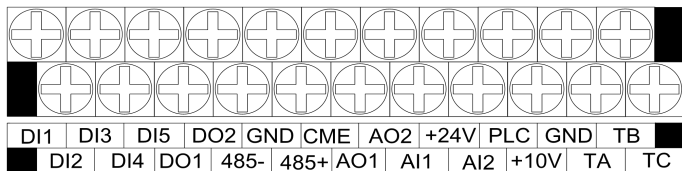

Figure 2-8 Arrangement Sequence of Control Plate Terminals

2.4.2 Control terminal function description is shown in Table 2-4.

Table 2-4 Control Terminal Function Table

Category	Terminal Label	Name	Terminal function description	Specification
Communication	485+	RS485 communication interface	RS485 differential signal positive terminal	For standard RS485 communication interface, please use twisted pair or shielded wire.
	485-		RS485 differential signal negative terminal	
Multifunctional output terminal	DO1	Open collector output terminal	It can be programmed and defined as switch output terminal with multiple functions, see terminal function parameter F6.11 for details/output terminal function introduction (common port CME)	Optocoupler isolated output; Working voltage range 9-30V; Maximum output current: 50mA
Multifunctional output terminal	DO2	Open collector output terminal	It can be programmed and defined as switch output terminal with multiple functions, see terminal function parameter F6.12 for details/output terminal function introduction (common port CME)	Optocoupler isolated output; Working voltage range 9-30V; Maximum output current: 50mA; Maximum output frequency: 50kHz;

Analog Input	AI1	Analog input AI1	AI1 terminal receiving analog current, and voltage input (selected and switched through jump cap)	Input voltage range: 0~10V (input impedance: 102k Ω) Resolution: 1/1000 Input current range: 0~20mA (input impedance: 255 Ω) Resolution: 1/1000
	AI2	Analog input AI2	Receives analog voltage input	Resolution: 1/1000
Analog output	AO1	Analog output	Provides analog voltage output, which can correspond to 12 physical quantities (see F5.25 for details)	Voltage output range: 0~10V
	AO2	Analog output	Provides analog voltage output, and current output (AO2 terminal can be realized by jump cap) can correspond to 12 physical quantities (see F5.26 for details)	Voltage output range: 0~10V Current output range: 0~20mA
Multifunctional input terminal	DI1	Multifunctional input terminal 1	It can be programmed and defined as switch input terminal with multiple functions, see Chapter VI for terminal function parameters (switch input and output) input terminal function introduction. (See F6.00-6.04 for details)	The forward and reverse functions can be configured for the terminal; DI5 can be used as a high-speed pulse input terminal, and the upper limit of the input frequency is 50kHz;
	DI2	Multifunctional input terminal 2		
	DI3	Multifunctional input terminal 3		

	DI4	Multifunctional input terminal 4		
	DI5	Multifunctional input terminal 5		
Power supply	+10V	+10V power supply	Provides +10V power supply for external use	Maximum output current: 20mA
	+24V	+24V power supply	Digital signal power supply	Maximum output current: 100mA
	GND	Power supply common port	Power reference ground (including +10V and +24V)	It is the only ground system on the control board.
	PLC	Multifunctional input common port	Common port of DI1-DI5	Shot-circuited to +24V as factory default.
	CME	Digital output common port	Common port of multifunctional DO1 and DO2.	Short-circuited to GND as factory default.
Relay output terminal	TA TB TC	Programmable relay output	Usually, TA-TB is normally open, and TA-TC is normally close; during operating, TA-TB is normally close, and TA-TC is normally open.	NO: 5A 250VAC NC: 3A 250VAC

2.4.3 Wiring of communication terminal

PLC or PC is used for master control, with the drive as the slave, which are connected through RS485. It can realize single master and single slave communication or single master and multiple slaves communication. With the increasing connection units, the communication system becomes more susceptible to the interference, so it is suggested to connect wires as follows (see Annex for communication protocol):

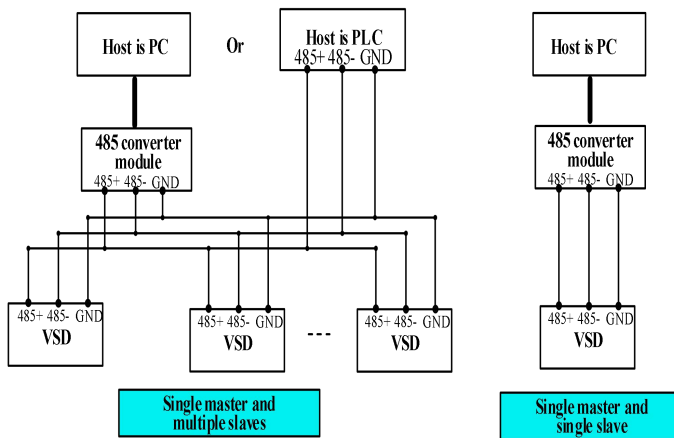
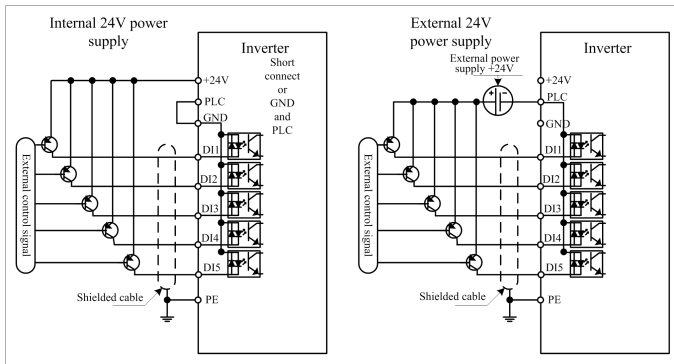

Figure 2-9 Wiring of Communication Terminal

2.4.4 Multifunctional contact input wiring

(1) Wiring method of PNP characteristic transistor



(2) Wiring method of NPN characteristic transistor

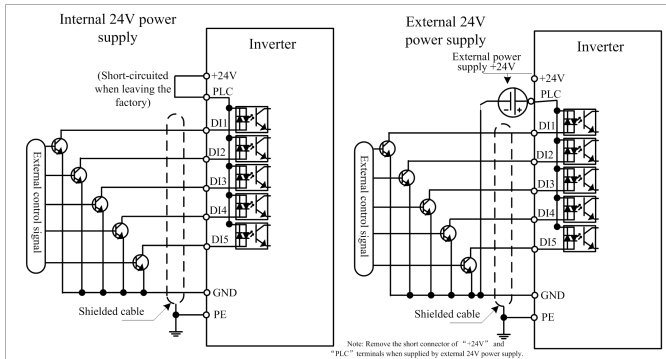















Chapter III Operation Instructions of Drive

3.1 Key function description

The drive operation panel is provided with 7 keys and 1 rotary encoder. The functions are defined in Table 3-1.

Table 3-1 Operation Panel Function Table

Key	Name	Label in the manual	Function description
	Program/Exit key		Enter or exit programming state
	Run key		In the operation mode, press this key to run the drive.
	Stop key		When the drive is in the normal running state and the drive's running instruction channel is set to the keypad, press this key to stop drive according to the set mode. When the drive is in the fault state, press this key to reset the drive and return to the normal stop state.
	Increase key		Increase data or function code
	Decrease key		Decrease data or function code
	Shift key		In the edit state, you can select the modification bit of the set data
	Rotary encoder		When pressed down, it is the ENT key, you can enter the drop-down menu or data confirmation.
			When the frequency channel is given by the keypad, the rotary encoder can modify the set

			frequency of the drive.
--	--	--	-------------------------

3.2 Keypad operation methods

You can perform various operations on the drive by keypad, as follows:

3.2.1 Shortcut monitoring parameter view

6 shortcut parameters are fixed to be displayed in the shortcut monitoring interface which can be switched by the Up or Down key. When the ENT key is pressed down in this interface, it will immediately return to the first shortcut parameter. 6 shortcut parameter sequence list is in the below table:

Shortcut parameter 1	Determined by function code FC.17
Shortcut parameter 2	Output current
Shortcut parameter 3	Bus voltage
Shortcut parameter 4	Set frequency
Shortcut parameter 5	All
Shortcut parameter 6	Terminal state 1

The above table shows shortcuts in the general mode, which will vary with different industry code for different industries.

3.2.2 Settings of function code parameters

The function parameter system of this drive includes function code F0 ~ FF group, monitoring parameter U0 group, and fault record parameter U1 group. Each function group includes several function codes. The function code is identified by (function code group number + function code number). For example, “F5.08” indicates the 8th function code of the 5th function group.

Function code setting example:

Example 1: Change the forward jog frequency setting from 5Hz to 10Hz (Change F2.20 from 5.00Hz to 10.00Hz)

1) Press the **PRG** key to enter the programming state, the digital display will show function parameter “-F0-” and press the **▲** key to make the LED display to show “-F2-”.

2) Press **ENT**, you will see the digital display shows function parameter “F2.00”.

3) Press the **▲** key to change the digital display to display function parameter “F2.20”.

4) Press the **ENT** key, you will see the value (5.00) corresponding to F2.20, meanwhile, the LED labeled “Hz” lights up.

5) Press the **▶▶** key and shift to the highest bit “5”, and press the **▲** key five times, to change to **10.00**.

6) Press the **ENT** key. If the parameter does not flash, it indicates the modification is successful.

7) Press the **PRG** key to exit the programming state.

Note: In P.off state, it is forbidden to modify the function code parameter.

3.2.3 Jog function operation



Use the keypad to perform the jog operation of the drive:



1) Press the **PRG** key three times to enter the jog operation state, and the digital tube displays function parameter “JOG-”.

- 2) Press and hold the Up key to forward jog.
- 3) Press and hold the Down key to reverse jog.

3.2.4 Parameter upload and download operations

The external keypad has the functionality of uploading and downloading the function code.

1) On the external keypad, press the  key + the  key, to execute the function code uploading function. The external keypad reads all the function code values from the control board, and then writes into the keypad memory chip.

2) On the external keypad, press the  key + the  key, to execute the function code downloading function. The external keypad reads all the function code values from the memory chip, and then writes into the drive control board chip. However, when downloading, the keypad will automatically distinguish the software version, drive voltage level, and drive power level. The specific conditions are as follows:

a. If the downloaded function code is inconsistent with the drive software version of the parameter to be downloaded, it will not be downloaded and an E028 fault will be reported.

b. If the downloaded function code is inconsistent with the drive voltage level of the parameter to be downloaded (e.g. The downloaded function code is of 2S model, but the drive is of 4T model), it will not be downloaded and an E028 fault will be reported.

c. If the downloaded function code is consistent with the drive voltage level of the parameter to be downloaded but the power level is inconsistent, only F3 group motor related parameters will not be downloaded, and all the other parameters will be downloaded normally.

d. If the downloaded function code is consistent with the drive software version, voltage level, and power level of the parameter to be downloaded, all parameters will be downloaded.

Remarks:

1. The machine's standard external keypad is a short-line keypad (the length of the keypad line is 15m or less). The keypad does not support online update software;

2. The long-line keypad (the length of the keypad line is 80m or less) is an optional accessory. The long-line keypad with LCD screen supports online software update. If the customer needs a long-line keypad, special instructions are needed for special treatment of the whole machine.

Chapter IV Function Parameter Table

4.1 Function parameter table

Description of symbols in the table:

- × - Indicates this parameter cannot be changed during the operation.
- - Indicates this parameter can be changed during the operation.
- - Indicates the actual test parameter, which cannot be changed.
- * - Indicates this parameter is the reserved parameter by the manufacturer, which is prohibited to be changed.

Parameter Code	Parameter name	Parameter detailed description	Minimum Unit	Factory value	Change
F0 group: system management parameter					
F0.00	Parameter operation protection	0: Password operation. You can view the function code value without entering a password, but you cannot change it. You need to enter the correct password in F0.05 before changing the function code. 1: Password operation. You cannot view the function code value when no password is entered, and the function code will display “-----”. You need to enter the correct password in F0.05 before viewing and changing the	1	0	○

Parameter Code	Parameter name	Parameter detailed description	Minimum Unit	Factory value	Change
		function code. Note: This function will take effect only after setting the function code operation password in F0.05.			
F0.01	Reserved	-	-	-	*
F0.02	Drive operation deadline	0~Maximum timing 65535h (0 indicates unlimited)	1h	0h	○
F0.03	Parameter initialization	0: No operation 1: Restore the factory settings (the drive model, running time, and fault records will not be restored) 2: Clear the fault memory information (clear fault memory parameters of U1 group)	1	0	×
F0.04	Industry code	0: Universal drive 1: Special drive for water supply 2: Solar pump Note: Changing the industry code will restore other function codes to their factory settings. The factory value of part of function codes of the special drive for water supply is set according to the	1	0	×

Parameter Code	Parameter name	Parameter detailed description	Minimum Unit	Factory value	Change												
		<p>following list:</p> <table border="1"> <thead> <tr> <th>Function code</th> <th>Factory value</th> </tr> </thead> <tbody> <tr> <td>F1.01</td> <td>1</td> </tr> <tr> <td>F1.02</td> <td>8</td> </tr> <tr> <td>F8.14</td> <td>4ms</td> </tr> <tr> <td>F8.15</td> <td>5.0%</td> </tr> <tr> <td>FC.17</td> <td>14</td> </tr> </tbody> </table>	Function code	Factory value	F1.01	1	F1.02	8	F8.14	4ms	F8.15	5.0%	FC.17	14			
Function code	Factory value																
F1.01	1																
F1.02	8																
F8.14	4ms																
F8.15	5.0%																
FC.17	14																
F0.05	Function code operation password	<p>Setting range: 0~65535 0 indicates no password, set any non-zero number, the password protection function will take effect immediately, please keep the set password in mind. After setting the password, if you want to clear the password, you must enter the correct password first, and then set the password value to 0. After setting the password, if you want to change the password, you must clear the password before you can set a new password.</p> <p>Note: The password protection authority is set in F0.00, which is used to prohibit unauthorized personnel from viewing/ changing the function code parameters.</p>	1	0	○												

Parameter Code	Parameter name	Parameter detailed description	Minimum Unit	Factory value	Change
Basic operating parameters of F1 group					
F1.00	Control method	0: Reserved 1: V/F control	1	1	×
F1.01	Run command channel selection	0: Operation panel run command channel 1: Terminal run command channel 2: Serial port run command channel	1	0	○
F1.02	Main frequency x given channel selection	0: Keypad's digital potentiometer 1: Digital input 1:By, setting frequency by modifying function code F1.05 (corresponding to auxiliary frequency Y) or F1.07 (corresponding to main frequency X). 2: Digital input 2:terminal UP/DN adjustment. 3: igital input 3 :By using communication input. 4: AI1 5: AI2	1	0	○
F1.03	Auxiliary frequency Y given channel selection	6: Terminal pulse input 7: Multistage instruction input:Select simple PLC operation or multistage speed operation through function code F9.00. 8: PID input 9: External keypad analog potentiometer input 10-15: Reserved	1	1	○

Parameter Code	Parameter name	Parameter detailed description	Minimum Unit	Factory value	Change
F1.04	Frequency source combination mode	0: X 1: Y 2: X+Y 3: X-Y 4: Max(X,Y) 5: Min(X,Y) Note: If the X and Y directions are not the same, the frequency direction after the combination of 2 and 3 is based on the main frequency X, while 4 and 5 is based on the selected frequency direction. Beside this, it is based on the absolute value of the main and auxiliary frequencies during calculations. If the calculated value is less than 0, it will run at zero frequency.	1	0	○
F1.05	Digital setting of auxiliary frequency Y	Lower limit frequency~upper limit frequency	0.01Hz	50.00 Hz	○
F1.06	Maximum output frequency	Upper limit frequency~650.00Hz	0.01Hz	50.00 Hz	×
F1.07	Main frequency X digital setting	Lower limit frequency~upper limit frequency	0.01Hz	50.00 Hz	○
F1.08	Reserved	-	-	-	*

Parameter Code	Parameter name	Parameter detailed description	Minimum Unit	Factory value	Change
F1.09	Upper limit frequency	Lower limit frequency~maximum output frequency	0.01Hz	50.00 Hz	○
F1.10	Lower limit frequency	0.00~upper limit frequency	0.01Hz	0.00Hz	○
F1.11	Acceleration time 1	0.01~600.00 Note: The default unit is s. For the selection of acceleration/deceleration time unit, see FC.07.	0.01	6.00	○
F1.12	Deceleration time 1	○			
F1.13	Acceleration/deceleration filtering time	0~1000Ms~1000ms (0 indicates no filtering)	1ms	0ms	○
F1.14	Reserved	-	-	-	*
F1.15	Reserved	-	-	-	*
F1.16	Reserved	-	-	-	*
F1.17	V/F curve setting	0: Straight line VF 1: User-set V/F curve, see F1.18~F1.23 function code setting for details. 2: Reduced torque characteristic curve 1 (2.0 power) 3: Reduced torque characteristic curve 2 (1.7 power) 4: Reduced torque characteristic curve 3 (1.2 power)	1	0	×
F1.18	V/F frequency value F1	0.00~F1.20	0.01Hz	12.50 Hz	×

Parameter Code	Parameter name	Parameter detailed description	Minimum Unit	Factory value	Change
F1.19	V/F voltage value V1	0~F1.21	0.1%	25.0%	×
F1.20	V/F frequency value F2	F1.18~F1.22	0.01Hz	25.00 Hz	×
F1.21	V/F voltage value V2	F1.19~F1.23	0.1%	50.0%	×
F1.22	V/F frequency value F3	F1.20~F3.04	0.01Hz	37.50 Hz	×
F1.23	V/F voltage value V3	F1.21~100.0%	0.1%	75.0%	×
F1.24	Running direction setting	0: Forward 1: Reverse	1	0	○
F1.25	Carrier frequency setting	1~15kHz	1kHz	4kHz	○
F2 group start-stop control					
F2.00	Start operation mode	LED single digit: Start mode 0: Start from start frequency 1: Brake and then start from the start frequency 2: Speed tracking restart LED tens digit: Speed tracking mode 0: Track down from the frequency of shutdown, usually this	11	00	×

Parameter Code	Parameter name	Parameter detailed description	Minimum Unit	Factory value	Change
		method is used. 1: Track down from the maximum frequency, suitable for power generation load.			
F2.01	Start frequency	0.20~60.00Hz	0.01Hz	0.50Hz	○
F2.02	Start frequency hold time	0.0~10.0s	0.1s	0.0s	○
F2.03	Start DC braking current	0.0~150.0% drive rated current	0.1%	100.0%	○
F2.04	Start DC braking time	0.0~30.0S (0.0 indicates the DC braking is not activated)	0.1s	0.0s	○
F2.05	Acceleration/deceleration mode selection	0: Linear acceleration/deceleration 1: Reserved	1	0	×
F2.06	Start protection selection (only valid for two-wire control)	This function realizes whether the drive automatically starts running when the drive is powered on, the fault is cleared, or the command channel is switched to the two-wire terminal mode. 0: If the run command is valid, the drive does start, and but the drive is in the running protection state.	1	0	×

Parameter Code	Parameter name	Parameter detailed description	Minimum Unit	Factory value	Change
		The drive will not run until the run command terminal is canceled and then the terminal is enabled. 1: If the run command is valid, the drive speed tracking starts. Note: For safety, be cautious when setting to 1.			
F2.07	Start protection wait time	Set range: 0.0~10.0s	0.1s	0.0s	○
F2.08	Stop mode	0: Decelerate and stop 1: Run freely and stop 2: Decelerate and stop + DC brake	1	0	×
F2.09	DC braking start frequency at stop	0.00~60.00Hz	0.01Hz	0.00Hz	○
F2.10	DC braking wait time at stop	0.00~10.00s	0.01s	0.10s	○
F2.11	DC braking current at stop	0.0~150.0% drive rated current	0.1%	100.0%	○
F2.12	DC braking time at stop	0.0~60.0S (0.0 indicates the DC braking does not act)	0.1s	0.0s	○
F2.13	Action selection within DC braking wait time at stop	0: No output 1: Run at the braking start frequency	1	1	○

Parameter Code	Parameter name	Parameter detailed description	Minimum Unit	Factory value	Change
F2.14	Acceleration time 2	Set range: 0.01~600.00 Note: The default unit is s. For the selection of acceleration/deceleration time unit, see FC.07.	0.01s	6.00s	○
F2.15	Deceleration time 2				○
F2.16	Acceleration time 3				○
F2.17	Deceleration time 3				○
F2.18	Acceleration time 4				○
F2.19	Deceleration time 4				○
F2.20	Jog run frequency	0.10~50.00Hz	0.01Hz	5.00Hz	○
F2.21	Jog interval time	0.0~100.0s	0.1s	0.0s	○
F2.22	Jog acceleration time	0.01~600.00s	0.01s	6.00s	○
F2.23	Jog deceleration time				○
F2.24	Jump frequency 1	0.00~650.00Hz	0.01Hz	0.00Hz	×
F2.25	Jump frequency 1 range	0.00~30.00Hz	0.01Hz	0.00Hz	×
F2.26	Jump frequency 2	0.00~650.00Hz	0.01Hz	0.00Hz	×
F2.27	Jump frequency 2 range	0.00~30.00Hz	0.01Hz	0.00Hz	×
F2.28	Jump frequency 3	0.00~650.00Hz	0.01Hz	0.00Hz	×

Parameter Code	Parameter name	Parameter detailed description	Minimum Unit	Factory value	Change																						
F2.29	Jump frequency 3 range	0.00~30.00Hz	0.01Hz	0.00Hz	×																						
F2.30	Forward and reverse dead zone time	0.00~360.00s	0.01s	0.01s	×																						
F3 group: motor and torque control parameters																											
F3.00	Motor model code	<p>Set range: 1~10 The motor model code indicates the power code.</p> <table border="1" style="margin-left: auto; margin-right: auto;"> <thead> <tr> <th>Mode l code</th> <th>Motor power</th> </tr> </thead> <tbody> <tr><td>1</td><td>2T 0.4kW</td></tr> <tr><td>2</td><td>2T 0.75kW</td></tr> <tr><td>3</td><td>2T 1.5kW</td></tr> <tr><td>4</td><td>2T 2.2kW</td></tr> <tr><td>5</td><td>4T 0.4kW</td></tr> <tr><td>6</td><td>4T 0.75kW</td></tr> <tr><td>7</td><td>4T 1.5kW</td></tr> <tr><td>8</td><td>4T 2.2kW</td></tr> <tr><td>9</td><td>4T 4.0kW</td></tr> <tr><td>10</td><td>4T 5.5kW</td></tr> </tbody> </table> <p>Note: 1. When the factory value is restored, this function code will be restored to the default value the same as the drive power. 2. When this function code is reset, F3.01~F3.10 motor parameters can be initialized.</p>	Mode l code	Motor power	1	2T 0.4kW	2	2T 0.75kW	3	2T 1.5kW	4	2T 2.2kW	5	4T 0.4kW	6	4T 0.75kW	7	4T 1.5kW	8	4T 2.2kW	9	4T 4.0kW	10	4T 5.5kW	1	Model determination	×
Mode l code	Motor power																										
1	2T 0.4kW																										
2	2T 0.75kW																										
3	2T 1.5kW																										
4	2T 2.2kW																										
5	4T 0.4kW																										
6	4T 0.75kW																										
7	4T 1.5kW																										
8	4T 2.2kW																										
9	4T 4.0kW																										
10	4T 5.5kW																										

Parameter Code	Parameter name	Parameter detailed description	Minimum Unit	Factory value	Change
F3.01	Rated power	0.4~999.9KW	0.1KW	Model determination	×
F3.02	Rated current	0.01~655.35A	0.01A		×
F3.03	Rated speed	1~65535rpm	1rpm		×
F3.04	Rated frequency	1.00~650.00Hz	0.01Hz		×
F3.05	Rated voltage	1~480V	1V		×
F3.06	No-load current I0	0.01~655.35A	0.01A	Model determination	×
F3.07	Stator resistance R1	0.000~50.000Ω	0.001Ω		○
F3.08	Leakage inductance X	0.0~6553.5mH	0.1mH		○
F3.09	Rotor resistance R2	0.000~50.000Ω	0.001Ω		○
F3.10	Mutual inductance Xm	0.0~6553.5mH	0.1mH		○
F3.11	Motor poles	2~14	2	4	×
F3.12	Parameter self-learning	0: No action 1: Action (motor rotation): Perform comprehensive self-learning of motor parameters. It is recommended to use rotary self-learning for occasions with high control accuracy	1	0	×

Parameter Code	Parameter name	Parameter detailed description	Minimum Unit	Factory value	Change
		requirements. Note: Before starting the self-learning, make sure that the motor is stopped and remove the load from the motor shaft, otherwise the self-learning will not be performed correctly.			
F3.13	Self-learning acceleration and deceleration speeds	0.01~600.00s	0.01s	6.00s	○
F3.14	Self-learning current	1~100%	1%	25%	×
F5 group: Analog terminal parameters					
F5.00	All minimum value	0.00~F5.02	0.01V	0.00V	○
F5.01	Set value corresponding to All minimum value	-100.0%~100.0%	0.1%	0.0%	○
F5.02	All maximum value	F5.00~10.00V	0.01V	10.00V	○
F5.03	Set value corresponding to All maximum value	-100.0%~100.0%	0.1%	100.0%	○

Parameter Code	Parameter name	Parameter detailed description	Minimum Unit	Factory value	Change
F5.04	AI1 zero drift setting	0.00~10.00V	0.01V	0.00V	○
F5.05	AI1 filter time	0~1000ms	1ms	10ms	○
F5.06	AI2 minimum value	0.00~F5.08	0.01V	0.00V	○
F5.07	Set value corresponding to AI2 minimum value	-100.0%~100.0%	0.1%	0.0%	○
F5.08	AI2 maximum value	F5.06~10.00V	0.01V	10.00V	○
F5.09	Set value corresponding to AI2 maximum value	-100.0%~100.0%	0.1%	100.0%	○
F5.10	AI2 zero drift setting	0.00~10.00V	0.01V	0.00V	○
F5.11	AI2 filter time	0~1000ms	1ms	10ms	○
F5.12	Reserved	-	-	-	*
F5.13	Reserved	-	-	-	*
F5.14	Reserved	-	-	-	*
F5.15	Reserved	-	-	-	*
F5.16	Reserved	-	-	-	*
F5.17	Reserved	-	-	-	*

Parameter Code	Parameter name	Parameter detailed description	Minimum Unit	Factory value	Change
F5.18	Analog automatic zero drift adjustment	Set range: 0~1 When set to 1, the automatic zero drift adjustment of the analog quantity must be performed. It must be ensured that there is no external analog quantity input.	0	0	○
F5.19	PULSE minimum input	0.00~F5.21	0.01kHz	0.00 kHz	○
F5.20	Corresponding setting of PULSE minimum input	-100.0%~100.0%	0.1%	0.0%	○
F5.21	PULSE maximum input	F5.19~50.00KHz	0.01kHz	50.00 kHz	○
F5.22	Corresponding setting of PULSE maximum input	-100.0%~100.0%	0.1%	100.0%	○
F5.23	PULSE filter time	0~1000ms	1ms	10ms	○
F5.24	HDO function selection (DO2 terminal)	0: Running frequency (0~Maximum output frequency) 1: Set frequency (0~Maximum output frequency) 2: Output current (0~2	1	5	○

Parameter Code	Parameter name	Parameter detailed description	Minimum Unit	Factory value	Change
F5.25	AO1 function selection	times rated current) 3: Output torque (0~2 times rated torque) 4: Output voltage (0~1.2 times rated voltage)	1	0	○
F5.26	AO2 function selection	5: Bus voltage (0~1000V) 6: AI1 (0~10V/0~20mA) 7: AI2 (0~10V) 8: Reserved 9: Output power (0~2 times rated frequency) 10: Pulse input (0~50.00kHz) 11: Communication setting (0~1000)	1	1	○
F5.27	HDO (DO2 terminal) output lower limit	0.0~F5.29	0.1%	0.0%	○
F5.28	Corresponding lower limit HDO (DO2 terminal) output frequency	0.00~50.00KHz	0.01KHz	0.00 KHz	○
F5.29	HDO (DO2 terminal) output upper limit	F5.27~100.0%	0.1%	100.0%	○

Parameter Code	Parameter name	Parameter detailed description	Minimum Unit	Factory value	Change
F5.30	Corresponding upper limit HDO (DO2 terminal) output frequency	0.00~50.00KHz	0.01KHz	50.00 KHz	○
F5.31	AO1 output lower limit	0.0~F5.33	0.1%	0.0%	○
F5.32	Corresponding lower limit AO1 output voltage	0.00~10.00V	0.01V	0.00V	○
F5.33	AO1 output upper limit	F5.31~100.0%	0.1%	100.0%	○
F5.34	Corresponding upper limit AO1 output voltage	0.00~10.00V	0.01V	10.00V	○
F5.35	AO2 output lower limit	0.0~F5.37	0.1%	0.0%	○
F5.36	Corresponding lower limit AO2 output voltage	0.00~10.00V	0.01V	0.00V	○
F5.37	AO2 output lower limit	F5.35~100.0%	0.1%	100.0%	○
F5.38	Corresponding upper limit AO2 output voltage	0.00~10.00V	0.01V	10.00V	○

Parameter Code	Parameter name	Parameter detailed description	Minimum Unit	Factory value	Change
F5.39	External keypad analog potentiometer zero drift setting	0.00~10.00V	0.01V	0.00V	○
F5.40	External keypad analog potentiometer zero filter time	0~1000ms	1ms	10ms	○
F6 group: Digital terminal parameters					
F6.00	Multifunctional input terminal DI1 function selection	0: No function 1: Forward running FWD (level + edge) 2: Reverse running REV (level + edge) 3: Three-wire running control Sin (level) 4: Forward jog (level) 5: Reverse jog (level) 6: Free stop (level) 7: Fault reset (edgesignal) 8: Run pause (level) 9: External fault input 10: Frequency setting increase (UP) 11: Frequency setting decreases (DOWN) 12: Multistage speed terminal 1 13: Multistage speed terminal 2 14: Multistage speed terminal 3 15: Multistage speed	1	1	×

Parameter Code	Parameter name	Parameter detailed description	Minimum Unit	Factory value	Change
F6.01	Multifunctional input terminal DI2 function selection	terminal 4 16: Acceleration/deceleration time selection 1 17: Acceleration/deceleration time selection 2 18: PLC pause 19: PLC operation stop and reset 20: PID control pause 21: PID parameter switching 22: Counter trigger 23: Counter reset 24: Length reset 25: Acceleration/deceleration prohibited (level) 26: Immediate DC braking 27: UP/DOWN setting cleared 28: Control command switched to keypad 29: Control command switched to terminal 30: Control command switched to communication 31: Frequency source switched to the main frequency X 32: Frequency source switched to auxiliary frequency Y 33: High-frequency pulse count reset 34: Non-water signal		2	

Parameter Code	Parameter name	Parameter detailed description	Minimum Unit	Factory value	Change
F6.02	Multifunctional input terminal DI3 function selection	<p>35: Full water signal</p> <p>Note: The function of each terminal should be different.. If the functions of the two terminals are set to same, the DI port ranked first will work first, and the latter ones will not work.</p> <p>Detailed description of terminal functions: 1~3: Forward running FWD, reverse running REV, three-wire running control Sin: For terminal two-wire and three-wire control signals, see function code F6.09 description for details. 4~5: Forward jog and reverse jog: Used for jog running control under terminal run command mode, the jog running frequency, jog interval time and jog acceleration/deceleration time are defined in F2.20~F2.23. 6: Free stop: If a signal is sent to the terminal set with this function, the driver terminates the output immediately, and the motor stops freely according to the</p>		7	
F6.03	Multifunctional input terminal DI4 function selection	<p>35: Full water signal</p> <p>Note: The function of each terminal should be different.. If the functions of the two terminals are set to same, the DI port ranked first will work first, and the latter ones will not work.</p> <p>Detailed description of terminal functions: 1~3: Forward running FWD, reverse running REV, three-wire running control Sin: For terminal two-wire and three-wire control signals, see function code F6.09 description for details. 4~5: Forward jog and reverse jog: Used for jog running control under terminal run command mode, the jog running frequency, jog interval time and jog acceleration/deceleration time are defined in F2.20~F2.23. 6: Free stop: If a signal is sent to the terminal set with this function, the driver terminates the output immediately, and the motor stops freely according to the</p>		12	

Parameter Code	Parameter name	Parameter detailed description	Minimum Unit	Factory value	Change
F6.04	Multifunctional input terminal DI5 function selection	mechanical inertia. 7: Fault reset: When a fault alarm occurs in the drive, the fault can be reset through this terminal. Its function is consistent with the STOP key function of the keypad. 8: Running pause: If this terminal is valid during running, the terminal will decelerate to zero frequency running according to the deceleration time. This function is invalid during jog running. 9: External fault input: The fault signals of external devices can be input through this terminal, which is convenient for the drive to monitor the faults of external devices. After receiving fault signals from external devices, the drive displays "E015", which is the fault alarm of external devices. 10~11: Frequency setting increase UP, and frequency setting decrease DOWN: The frequency increase or decrease is realized through the control terminal, to perform remote control replacing		13	
F6.05	Reserved			0	

Parameter Code	Parameter name	Parameter detailed description	Minimum Unit	Factory value	Change																																																		
F6.06	Reserved	the keypad. Effective when the main frequency F1.02 = 2 or the auxiliary frequency F1.03 = 2, the acceleration/deceleration rate is set by F6.10. 12~15: Multistage speed terminals 1~4: By selecting the terminal ON/OFF combination of these functions, you can define up to 16 stages of different speeds, frequency of multistage instructions, the selection of acceleration/deceleration time, and the rotating direction are set in group F9.		0																																																			
F6.07	Reserved	<table border="1"> <thead> <tr> <th>K 4</th> <th>K 3</th> <th>K 2</th> <th>K 1</th> <th>Frequency setting</th> </tr> </thead> <tbody> <tr> <td>O F F</td> <td>O F F</td> <td>O F F</td> <td>O F F</td> <td>Multistage instruction 1</td> </tr> <tr> <td>O F F</td> <td>O F F</td> <td>O F F</td> <td>O N</td> <td>Multistage instruction 2</td> </tr> <tr> <td>O F F</td> <td>O F F</td> <td>O N</td> <td>O F F</td> <td>Multistage instruction 3</td> </tr> <tr> <td>O F F</td> <td>O F F</td> <td>O N</td> <td>O N</td> <td>Multistage instruction 4</td> </tr> <tr> <td>O F F</td> <td>O N</td> <td>O F F</td> <td>O F F</td> <td>Multistage instruction 5</td> </tr> <tr> <td>O F F</td> <td>O N</td> <td>O F F</td> <td>O N</td> <td>Multistage instruction 6</td> </tr> <tr> <td>O F F</td> <td>O N</td> <td>O N</td> <td>O F F</td> <td>Multistage instruction 7</td> </tr> <tr> <td>O F F</td> <td>O N</td> <td>O N</td> <td>O N</td> <td>Multistage instruction 8</td> </tr> <tr> <td>O N</td> <td>O F</td> <td>O F</td> <td>O F</td> <td>Multistage</td> </tr> </tbody> </table>	K 4	K 3	K 2	K 1	Frequency setting	O F F	O F F	O F F	O F F	Multistage instruction 1	O F F	O F F	O F F	O N	Multistage instruction 2	O F F	O F F	O N	O F F	Multistage instruction 3	O F F	O F F	O N	O N	Multistage instruction 4	O F F	O N	O F F	O F F	Multistage instruction 5	O F F	O N	O F F	O N	Multistage instruction 6	O F F	O N	O N	O F F	Multistage instruction 7	O F F	O N	O N	O N	Multistage instruction 8	O N	O F	O F	O F	Multistage		0	
K 4	K 3	K 2	K 1	Frequency setting																																																			
O F F	O F F	O F F	O F F	Multistage instruction 1																																																			
O F F	O F F	O F F	O N	Multistage instruction 2																																																			
O F F	O F F	O N	O F F	Multistage instruction 3																																																			
O F F	O F F	O N	O N	Multistage instruction 4																																																			
O F F	O N	O F F	O F F	Multistage instruction 5																																																			
O F F	O N	O F F	O N	Multistage instruction 6																																																			
O F F	O N	O N	O F F	Multistage instruction 7																																																			
O F F	O N	O N	O N	Multistage instruction 8																																																			
O N	O F	O F	O F	Multistage																																																			
F6.08	Reserved	<table border="1"> <tbody> <tr> <td>O F F</td> <td>O N</td> <td>O F F</td> <td>O N</td> <td>Multistage instruction 6</td> </tr> <tr> <td>O F F</td> <td>O N</td> <td>O N</td> <td>O F F</td> <td>Multistage instruction 7</td> </tr> <tr> <td>O F F</td> <td>O N</td> <td>O N</td> <td>O N</td> <td>Multistage instruction 8</td> </tr> <tr> <td>O N</td> <td>O F</td> <td>O F</td> <td>O F</td> <td>Multistage</td> </tr> </tbody> </table>	O F F	O N	O F F	O N	Multistage instruction 6	O F F	O N	O N	O F F	Multistage instruction 7	O F F	O N	O N	O N	Multistage instruction 8	O N	O F	O F	O F	Multistage		0																															
O F F	O N	O F F	O N	Multistage instruction 6																																																			
O F F	O N	O N	O F F	Multistage instruction 7																																																			
O F F	O N	O N	O N	Multistage instruction 8																																																			
O N	O F	O F	O F	Multistage																																																			

Parameter Code	Parameter name	Parameter detailed description				Minimum Unit	Factory value	Change
			F	F	F	instruction 9		
		ON	OFF	OFF	ON	Multistage instruction 10		
		ON	OFF	ON	OFF	Multistage instruction 11		
		ON	OFF	ON	ON	Multistage instruction 12		
		ON	ON	OFF	OFF	Multistage instruction 13		
		ON	ON	OFF	ON	Multistage instruction 14		
		ON	ON	ON	OFF	Multistage instruction 15		
		ON	ON	ON	ON	Multistage instruction 16		
		16~17: Acceleration/deceleration time selection 1~2: The ON/OFF combination of acceleration/deceleration time terminals 1 and 2 can realize the selection of acceleration/deceleration time 1~4.						
		K2	K1	Acceleration/d eceleration time selection				
		OFF	OFF	Acceleration/d eceleration time 1				
		OFF	ON	Acceleration/d eceleration time 1				
		ON	OFF	Acceleration/d eceleration time 3				
		ON	ON	Acceleration/d eceleration time 4				

Parameter Code	Parameter name	Parameter detailed description	Minimum Unit	Factory value	Change
		<p>18: PLC pause: Used to pause the drive's PLC running process. When this terminal is valid, it runs at zero frequency.</p> <p>19: PLC running stop and reset: PLC is prohibited from starting when the terminal is valid, deceleration and stop control is implemented for the PLC running process, and the PLC is reset to the initial state.</p> <p>20: PID control pause: PID is temporarily not available, and the drive maintains the current output frequency without performing PID adjustment.</p> <p>21: PID parameter switching: When the PID parameter switching condition (F8.12) is set to 1 (via terminal switching), the F8.06~F8.08 are used for PID parameters when the terminal is invalid, and F8.09~F8.11 are used when the terminal is valid.</p> <p>22: Counter trigger: Count pulse input port of the built-in counter, the highest pulse frequency: 50Hz, and the current count value can be stored and memorized when</p>			

Parameter Code	Parameter name	Parameter detailed description	Minimum Unit	Factory value	Change
		<p>power is off. (See function codes F6.22 and F6.23 for details).</p> <p>23: Counter reset: Clear the built-in counter of the drive and use it in conjunction with function 22 (counter trigger signal input).</p> <p>24: Length reset: When the function terminal is valid, the actual length is cleared to zero.</p> <p>25: Acceleration/deceleration prohibition: Keep the motor from being affected by any external signal (except stop command), drive keeps on operating at the current speed. This function is invalid during jog running.</p> <p>26: Immediate DC brake: When the drive is decelerating and is in stop + DC brake mode, it applies DC brake when this terminal is valid.</p> <p>27: UP/DOWN setting is cleared: When the frequency given channel is set to terminal UP/DOWN, this function terminal can directly clear the frequency set by UP/DOWN.</p> <p>28: Control command switch to keypad</p> <p>29: Control command</p>			

Parameter Code	Parameter name	Parameter detailed description	Minimum Unit	Factory value	Change
		<p>switch to input terminal 30: Control command switch to communication</p> <p>If all three or two of the above terminals are closed at the same time, the priority is keypad> terminal> communication.</p> <p>Note: When switching to terminal two-wire control, the running state changes are affected by the F2.06 parameter; when switching to other control modes, the current running state is maintained.</p> <p>31: Switch frequency source to the main to the main frequency X</p> <p>32: Switch frequency source to the main to auxiliary frequency Y</p> <p>If the above two terminals are closed at the same time, the priority is switching to the main frequency X> switching to the auxiliary frequency Y</p> <p>33: High-frequency pulse count reset: The high-frequency pulse count value recorded by function code U0.16 will be cleared.</p>			

Parameter Code	Parameter name	Parameter detailed description	Minimum Unit	Factory value	Change
F6.09	Forward/reverse running mode setting	0: Two-wire control mode 1 1: Two-wire control mode 2 2: Three-wire running control 1 3: Three-wire running control 2	1	0	×
F6.10	UP/DN rate	0.01~99.99Hz/s	0.01Hz/s	1.00 Hz/s	○
F6.11	Open collector output terminal DO1	0: No output 1: Drive running signal (RUN) 2: Frequency reached signal (FAR) 3: Frequency level detection signal (FDT1) 4: Frequency level detection signal (FDT2) 5: Reserved 6: Undervoltage lockout stopping (LU) 7: External fault stop (EXT) 8: Frequency upper limit (FHL) 9: Frequency lower limit (FLL) 10: Drive running at zero frequency 11: PLC phase running completion	1	0	×

Parameter Code	Parameter name	Parameter detailed description	Minimum Unit	Factory value	Change
F6.12	Open collector output terminal HDO (DO2 terminal)	12: PLC cycle completion 13: Set count value reached 14: Specified count value reached 15: Set length reached 16: Drive ready to run (RDY) 17: Drive fault 18: Reserved 19: Set cumulative running time reached 20: Forward running 21: Reverse running 22: Reserved 23: Water supply sleep running indication	1	1	×
F6.13	Relay output function (TA/TB/TC)	24: Water pipe overpressure indication 25: Water pipe underpressure indication 26: Water shortage in pipe indication 27: Underload alarm 28: Weak light	1	17	×
F6.14	FDT1 level	0.00~650.00Hz	0.01Hz	50.00 Hz	○
F6.15	FDT1 lag	0.00~650.00Hz	0.01Hz	1.00Hz	○
F6.16	FDT2 level	0.00~650.00Hz	0.01Hz	25.00 Hz	○
F6.17	FDT2 lag	0.00~650.00Hz	0.01Hz	1.00Hz	○

Parameter Code	Parameter name	Parameter detailed description	Minimum Unit	Factory value	Change
F6.18	Frequency arrival (FAR) detection width	0.00~650.00Hz	0.01Hz	2.50Hz	○
F6.19	HDI terminal input mode selection (DI5)	0: Switch input 1: High-frequency pulse input (see F5.19~F5.23)	1	0	×
F6.20	HDO terminal output mode selection (DO2)	0: Switch output 1: High-frequency pulse output (see F5.27~F5.30)	1	0	×
F6.21	Reserved	-	-	-	*
F6.22	Counter reset value setting (set count value reached)	F6.23~9999	1	0	○
F6.23	Counter detection value setting (specified count value reached)	0~F6.22	1	0	○

Parameter Code	Parameter name	Parameter detailed description	Minimum Unit	Factory value	Change
F6.24	DI input switch polarity 1	00000~11111 LED single digit: DI1 positive/negative logic definition LED tens digit: DI2 positive/negative logic definition LED hundreds digit: DI3 positive/negative logic definition LED thousands digit: DI4 positive/negative logic definition LED 10 thousands digit: DI5 positive/negative logic definition	11111	11111	○
F6.25	DI input switch polarity 2	00000~11111 LED single digit: Reserved LED tens digit: Reserved LED hundreds digit: Reserved LED thousands digit: Reserved LED 10 thousands digit: Reserved	11111	11111	○
F6.26	DO output switch polarity 1	00000~11111 LED single digit: DO1 positive/negative logic definition LED tens digit: DO2 positive/negative logic definition LED hundreds digit: Relay positive/negative logic definition LED thousands digit: Reserved LED 10 thousands digit: Reserved	11111	11111	○

Parameter Code	Parameter name	Parameter detailed description	Minimum Unit	Factory value	Change
F6.27	Reserved	-	-	-	*
F6.28	DI filter time	0~1000ms	1ms	20ms	○
F6.29	DO1 output on delay	0.0~600.0s	0.1s	0.0s	○
F6.30	DO1 output off delay	0.0~600.0s	0.1s	0.0s	○
F6.31	DO2 output on delay	0.0~600.0s	0.1s	0.0s	○
F6.32	DO2 output off delay	0.0~600.0s	0.1s	0.0s	○
F6.33	Relay output on delay	0.0~600.0s	0.1s	0.0s	○
F6.34	Relay output off delay	0.0~600.0s	0.1s	0.0s	○
F7 group: Advanced function parameters					
F7.00	Overvoltage stall point	100.0~160.0%Udc	0.1% Udc	Model determination	○
F7.01	Overvoltage control voltage	0.000~10.000V	0.001V	5.000V	○
F7.02	Overvoltage stall gain Kp	0~1000	1	5	○
F7.03	Overvoltage stall integration time	1~1000ms	1ms	200ms	○

Parameter Code	Parameter name	Parameter detailed description	Minimum Unit	Factory value	Change
F7.04	Overcurrent stall level	80.0~230.0%	0.1%	180.0%	○
F7.05	Overcurrent stall action selection	0: Constant speed invalid 1: Constant speed valid Note: Acceleration and deceleration are always valid.	1	1	○
F7.06	Overcurrent stall gain Kp	0~1000	1	5	○
F7.07	Overcurrent stall integration time	1~1000ms	1ms	200ms	○
F7.08	Speed tracking gain Kp	0~100	1	10	○
F7.09	Speed tracking integration time	1~1000ms	1ms	50ms	○
F7.10	Speed tracking acceleration and deceleration	0.1~600.0s	0.1s	20.0s	○
F7.11	Speed tracking threshold	1~100%	1%	10%	○

Parameter Code	Parameter name	Parameter detailed description	Minimum Unit	Factory value	Change
F7.12	Speed tracking filter time	1~100%	1%	3%	○
F7.13	Instant stop/nonstop function selection	0: Invalid 1: Decelerate	1	0	○
F7.14	Instant stop action pause judgment voltage	80.0~100.0%	0.1%	90.0%	○
F7.15	Instant stop voltage rise judgment time	0.00~100.00s	0.01s	0.50s	○
F7.16	Instant stop action judgment voltage	70.0~100.0%	0.1%	80.0%	○
F7.17	Instant stop gain Kp	0~1000	1	5	○
F7.18	Instant stop integration time	1~1000ms	1ms	100ms	○
F7.19	Instant stop deceleration time setting	0~300.0s	0.1s	20.0s	○
F7.20	Overcurrent stall speed recovery time limit	0.01~600.00s	0.01s	0.20s	○
F7.21	Torque	0.1~30.0%	0.1%	10.0%	○

Parameter Code	Parameter name	Parameter detailed description	Minimum Unit	Factory value	Change
	boost limit				
F7.22	Torque boost cutoff point	0.00~F3.04	0.01Hz	50.00 Hz	○
F7.23	Torque boost gain 1	0~500 (when set to 0, it is manual torque boost)	1	20	○
F7.24	Torque boost integration time 1	1~10000ms	1ms	150ms	○
F7.25	Torque boost gain switching frequency point	0.00~F3.04	0.01Hz	Model determination	○
F7.26	Torque boost gain 2	0~500	1	10	○
F7.27	Torque boost integration time 2	1~10000ms	1ms	500ms	○
F7.28	Automatic torque boost factor	0~100%	1%	30%	○
F7.29	Motor oscillation suppression methods	0: Suppress oscillation by adjusting output frequency 1: Suppress oscillation by adjusting output voltage	1	0	○
F7.30	Motor	0~1000	1	3	○

Parameter Code	Parameter name	Parameter detailed description	Minimum Unit	Factory value	Change
	oscillation suppression coefficient				
F7.31	Motor oscillation suppression filter time	0~10000ms	1ms	100ms	○
F8 group: PID control parameters					
F8.00	PID operation control selection	0: PID standby (not acting) 1: PID standby (acting)	1	0	×
F8.01	Target value channel selection	0: F8.05 digital given 1: AI1 2: AI2 3: Reserved 4: PULSE setting 5: Communication setting 6: Multistage instruction setting 7: Keypad digital potentiometer input 8: Analog potentiometer input on external keypad	1	0	×
F8.02	Feedback channel selection	0: AI1 1: AI2 2: Reserved 3: Pulse 4: Communication setting	1	0	×

Parameter Code	Parameter name	Parameter detailed description	Minimum Unit	Factory value	Change
F8.03	Target value channel filter	0~1000ms	1ms	10ms	○
F8.04	Feedback channel filter	0~1000ms	1ms	10ms	○
F8.05	Target quantity digital setting	Universal drive mode: 0.0~100.0% Special drive mode for water supply: 0.0~F8.23	0.1% or 0.1bar	0.0% or 0.0bar	○
F8.06	Proportional gain Kp1	0~1000	1	10	○
F8.07	Integration time Ti1	1~10000ms	1ms	500ms	○
F8.08	Differential time Td1	0~10000ms	1ms	0ms	○
F8.09	Proportional gain Kp2	0~1000	1	5	○
F8.10	Integration time Ti2	1~10000ms	1ms	2000ms	○
F8.11	Differential time Td2	0~10000ms	1ms	0ms	○
F8.12	Gain switching conditions	0: Do not switch 1: Switch through DI terminal 2: Switch automatically based on deviation 3: Switch automatically according to PID output	1	0	○

Parameter Code	Parameter name	Parameter detailed description	Minimum Unit	Factory value	Change
F8.13	Gain switching threshold	0.0~100.0%	0.1%	0.0%	○
F8.14	PID sampling period	1~60000ms	1ms	1ms	○
F8.15	Deviation limit	0.0~50.0%	0.1%	0.0%	○
F8.16	Closed-loop regulation features	0: Positive action 1: Negative action	1	0	○
F8.17	PID initial value	0.0~100.0%	0.1%	0.0%	×
F8.18	PID initial value hold time	0.00~600.00s	0.01s	0.00s	×
F8.19	Closed-loop output polarity selection	0: Closed-loop output is negative, run at zero-frequency 1: Closed-loop output is negative, reverse	1	0	○
F8.20	PID reverse cutoff frequency	0.00~upper limit frequency	0.01Hz	2.00Hz	×
F8.21	PID feedback loss detection value	0.0~100.0%	0.1%	10.0%	○

Parameter Code	Parameter name	Parameter detailed description	Minimum Unit	Factory value	Change
F8.22	PID feedback loss detection time	0.0~200.0S (0.0s indicates no detection)	0.1s	0.0s	○
F8.23	Maximum sensor range	0.0~200.0bar	0.1bar	10.0bar	○
F8.24	Water supply sleep selection	0: Automatic sleep 1: Run at lower frequency	1	0	○
F8.25	Water supply sleep detection time	0.0~3600.0s	0.1s	10.0s	○
F8.26	Water supply sleep deceleration time	0.01~600.00s	0.01s	10.00s	○
F8.27	Water supply wake-up pressure level	0.0~100.0% (100.0% is the set pressure value)	0.1%	10.0%	○
F8.28	Water supply wake detection time	0.0~3600.0s	0.1s	2.0s	○

Parameter Code	Parameter name	Parameter detailed description	Minimum Unit	Factory value	Change
F8.29	Water pressure overpressure alarm detection value	0.0~100.0% (Do not test when set to 0, 100.0% is the maximum range of pressure sensor)	0.1%	90.0%	○
F8.30	Water pressure undervoltage alarm detection value	0.0~100.0% (Do not test when set to 0, 100.0% is the maximum range of pressure sensor)	0.1%	0.0%	○
F8.31	Water pressure abnormal alarm detection time	0.0~3600.0s	0.1s	50.0s	○
F8.32	Water shortage alarm set value	0.0~100.0% (100.0% is the set pressure value)	0.1%	20.0%	○
F8.33	Water shortage alarm detection time	0.0~3600.0s	0.1s	20.0s	○
F8.34	Water shortage restart wait time	0~10000min (0min indicate there's no water shortage restart function)	1min	0min	○

Parameter Code	Parameter name	Parameter detailed description	Minimum Unit	Factory value	Change
F9 group: Multistage speed control parameters					
F9.00	Simple PLC run mode selection	LED single digit: PLC run mode 0: No action 1: Stop after a single cycle 2: Keep the final value after a single cycle 3: Continuous cycle 4: DI selective operation LED tens digit: Start mode 0: Start running from the first stage 1: Continue running from the stage of interruption LED hundreds digit: Stage time unit selection 0: Second 1: Minute LED thousands digit: Store at power failure 0: Do not store at power failure 1: Store the stage at power failure	1111	0000	×
F9.01	Running stages	1~16	1	16	○
F9.02	Multistage instruction 1	Lower limit frequency~upper limit frequency	0.01Hz	20.00 Hz	○

Parameter Code	Parameter name	Parameter detailed description	Minimum Unit	Factory value	Change
F9.03	Stage 1 instruction setting	<p>LED single digit: 0: Multistage instruction 1 (F9.02) 1: AI1 2: AI2 3: Pulse frequency 4: Communication 5: Keypad digital potentiometer input 6: External keypad's analog potentiometer input</p> <p>LED tens digit: 0: Acceleration/deceleration time 1 1: Acceleration/deceleration time 2 2: Acceleration/deceleration time 3 3: Acceleration/deceleration time 4</p> <p>LED hundreds digit: 0: Forward running 1: Reverse running</p> <p>Note: Only the LED single digit frequency source of stage 1 instruction can be set.</p>	111	000	○
F9.04	Stage 1 instruction running time	<p>Set range: 0.1~6000.0</p> <p>Note: For the time unit selection, see F9.00 hundreds digit setting.</p>	0.1	10.0	○

Parameter Code	Parameter name	Parameter detailed description	Minimum Unit	Factory value	Change
F9.05	Multistage instruction 2	Stage X instruction (F9.05, F9.08, F9.11, F9.14, F9.17, F9.20, F9.23, F9.26, F9.29, F9.32, F9.35, F9.38, F9.41, F9.44, and F9.47) setting range: Lower limit frequency~upper limit frequency Stage X instruction (F9.06, F9.09, F9.12, F9.15, F9.18, F9.21, F9.24, F9.27, F9.30, F9.33, F9.36, F9.39, F9.42, F9.45, and F9.48) setting range: LED single digit: 0: Multistage instruction x 1: Reserved LED tens digit: 0: Acceleration/deceleration time 1 1: Acceleration/deceleration time 2 2: Acceleration/deceleration time 3 3: Acceleration/deceleration time 4 LED hundreds digit: 0: Forward running 1: Reverse running Stage X instruction	0.01Hz	20.00 Hz	○
F9.06	Stage 2 instruction setting		111	000	○
F9.07	Stage 2 instruction running time		0.1	10.0	○
F9.08	Multistage instruction 3		0.01Hz	20.00 Hz	○
F9.09	Stage 3 instruction setting		111	000	○
F9.10	Stage 3 instruction running time		0.1	10.0	○
F9.11	Multistage instruction 4		0.01Hz	20.00 Hz	○
F9.12	Stage 4 instruction setting		111	000	○
F9.13	Stage 4 instruction running time		0.1	10.0	○
F9.14	Multistage instruction		0.01Hz	20.00 Hz	○

Parameter Code	Parameter name	Parameter detailed description	Minimum Unit	Factory value	Change
	5	running time (F9.07, F9.10, F9.13, F9.16, F9.19, F9.22, F9.25, F9.28, F9.31, F9.34, F9.37、 F9.40, F9.43, F9.46, and F9.49) setting range: 0.1~6000.0 Note: For the time unit selection, see F9.00 hundreds digit setting.			
F9.15	Stage 5 instruction setting		111	000	○
F9.16	Stage 5 instruction running time		0.1	10.0	○
F9.17	Multistage instruction 6		0.01Hz	20.00 Hz	○
F9.18	Stage 6 instruction setting		111	000	○
F9.19	Stage 6 instruction running time		0.1	10.0	○
F9.20	Multistage instruction 7		0.01Hz	20.00 Hz	○
F9.21	Stage 7 instruction setting		111	000	○
F9.22	Stage 7 instruction running time		0.1	10.0	○
F9.23	Multistage instruction 8		0.01Hz	20.00 Hz	○

Parameter Code	Parameter name	Parameter detailed description	Minimum Unit	Factory value	Change
F9.24	Stage 8 instruction setting		111	000	○
F9.25	Stage 8 instruction running time		0.1	10.0	○
F9.26	Multistage instruction 9		0.01Hz	20.00 Hz	○
F9.27	Stage 9 instruction setting		111	000	○
F9.28	Stage 9 instruction running time		0.1	10.0	○
F9.29	Multistage instruction 10		0.01Hz	20.00 Hz	○
F9.30	Stage 10 instruction setting		111	000	○
F9.31	Stage 10 instruction running time		0.1	10.0	○
F9.32	Multistage instruction 11		0.01Hz	20.00 Hz	○

Parameter Code	Parameter name	Parameter detailed description	Minimum Unit	Factory value	Change
F9.33	Stage 11 instruction setting		111	000	○
F9.34	Stage 11 instruction running time		0.1	10.0	○
F9.35	Multistage instruction 12		0.01Hz	20.00 Hz	○
F9.36	Stage 12 instruction setting		111	000	○
F9.37	Stage 12 instruction running time		0.1	10.0	○
F9.38	Multistage instruction 13		0.01Hz	20.00 Hz	○
F9.39	Stage 13 instruction setting		111	000	○
F9.40	Stage 13 instruction running time		0.1	10.0	○
F9.41	Multistage instruction 14		0.01Hz	20.00 Hz	○

Parameter Code	Parameter name	Parameter detailed description	Minimum Unit	Factory value	Change
F9.42	Stage 14 instruction setting		111	000	○
F9.43	Stage 14 instruction running time		0.1	10.0	○
F9.44	Multistage instruction 15		0.01Hz	20.00 Hz	○
F9.45	Stage 15 instruction setting		111	000	○
F9.46	Stage 15 instruction running time		0.1	10.0	○
F9.47	Multistage instruction 16		0.01Hz	20.00 Hz	○
F9.48	Stage 16 instruction setting		111	000	○
F9.49	Stage 16 instruction running time		0.1	10.0	○
FA group: Protection function parameters					

Parameter Code	Parameter name	Parameter detailed description	Minimum Unit	Factory value	Change
FA.00	DC bus undervoltage protection limit	50~999V	1V	Model determination	×
FA.01	Undervoltage fault action selection	0: During running, if the voltage is lower than the undervoltage limit, an undervoltage fault E007 is reported. 1: During running, if the voltage is lower than the undervoltage limit, P.oFF is reported.	1	0	×
FA.02	Motor overload protection action selection	0: No action 1: Action, E008 fault is reported when the motor is overloaded.	1	0	×
FA.03	Reserved	-	-	-	*
FA.04	Reserved	-	-	-	*
FA.05	Reserved	-	-	-	*
FA.06	Output phase loss protection delay time	0.0~6000.0s (0.0s indicates no detection for output phase loss)	0.1s	0.0s	×
FA.07	485 communication fault protection action selection	0: No action 1: Action, E016 fault is reported when 485 communication is abnormal.	1	0	×

Parameter Code	Parameter name	Parameter detailed description	Minimum Unit	Factory value	Change
FA.08	Number of automatic resets	0~100 (0 indicates no automatic reset function)	1	0	×
FA.09	Automatic reset interval time	0.1~1000.0s	0.1s	5.0s	×
FA.10	Reserved	-	-	-	*
FA.11	Reserved	-	-	-	*
FA.12	Reserved	-	-	-	*
Fb group:Serial communication parameters					
Fb.00	Local address	0~247 Note: 0 is the broadcast address	1	1	×
Fb.01	Communication configuration	LED single digit: Baud rate selection 0: 1200BPS 1: 2400BPS 2: 4800BPS 3: 9600BPS 4: 19200BPS 5: 38400BPS LED tens digit: Data format 0: 1-8-2-N format, RTU 1: 1-8-1-E format, RTU 2: 1-8-1-O format, RTU 3: 1-7-2-N format, ASCII 4: 1-7-1-E format, ASCII 5: 1-7-1-O format, ASCII 6: 1-8-1-N format, RTU	11	03	×

Parameter Code	Parameter name	Parameter detailed description	Minimum Unit	Factory value	Change
Fb.02	Reserved	-	-	-	*
Fb.03	Local response delay	0~1000ms	1	5ms	×
Fb.04	Communication timeout detection time	0.0~100.0s	0.1s	0.0s	×
Fb.05	Host send selection	LED single digit: Current host running status 0: Invalid 1: Valid LED tens digit: Current host running frequency 0: Invalid 1: Valid Note: Only RTU communication mode supports host sending.	11	11	×
FC group: Auxiliary function parameters					
FC.00	Energy consumption braking threshold	350~800V	1V	Model determination	×
FC.01	Energy consumption braking duty cycle	0~100%	1%	50%	×
FC.02	AVR function	0: Disable 1: Always enabled 2: Disable only during deceleration	1	2	×

Parameter Code	Parameter name	Parameter detailed description	Minimum Unit	Factory value	Change
FC.03	Automatic energy-saving operation	0: Disable 1: Enable	1	0	○
FC.04	Slip compensation gain	0~1000 (0 indicates no compensation)	1	0	○
FC.05	Slip compensation filter time	0.1~20.0ms	0.1ms	10.0ms	○
FC.06	Cooling fan control	0: Run in automatic mode Note: The fan is turned off at least 3 minutes after stop and when the temperature is lower than 40 degrees. 1: The fan keeps rotating during power-on	1	0	×
FC.07	Acceleration/deceleration time unit	0: Second 1: Minute	1	0	×
FC.08	Droop control frequency	0.00~10.00Hz	0.01Hz	0.00Hz	○
FC.09	Deceleration factor	50.0%~180.0%	0.1%	100.0%	○
FC.10	Zero frequency reached range	0.00~10.00Hz	0.01Hz	0.00Hz	○

Parameter Code	Parameter name	Parameter detailed description	Minimum Unit	Factory value	Change
FC.11	Set length	0 ~ 65535m (0 indicates the fixed length stop function is invalid)	1m	0m	○
FC.12	Measuring shaft circumference	0.001~10.000m	0.001m	0.100m	○
FC.13	Pulse per revolution	1~9999	1	1	○
FC.14	Dead zone compensation coefficient	0~20	1	Model determination	×
FC.15	STOP key stop function selection	0: Only valid for keypad control 1: Valid for all control modes except two-wire control mode	1	0	○
FC.16	Digital potentiometer power failure save selection	0: The digital potentiometer frequency is not saved during power failure, and will start from 0.00Hz after power-on. 1: The digital potentiometer frequency is saved during power failure, and will start from the power failure frequency after power-on.	1	1	○

Parameter Code	Parameter name	Parameter detailed description	Minimum Unit	Factory value	Change
FC.17	The first shortcut parameter display selection	Set range: 0~29 When set to 0~28, it corresponds to group U0 parameter subscript; when set to 29, it displays the operation frequency during fixed operation, and displays the instruction frequency during standby; when set to 4, it displays the operation speed during fixed operation, and displays the instruction speed during standby; when set to 5, it displays the operating linear speed during fixed operation, and displays the instruction linear speed during standby.	1	29	○
FC.18	Speed display factor	0.01~100.00 Note: Speed = $120 \times \text{frequency} \times \text{FC.18} / \text{n}$ number of motor poles (F3.11)	0.01	1.00	○
FC.19	Linear speed display factor	0.01~100.00 Note: Linear speed = $\text{speed} \times \text{FC.19}$	0.01	1.00	○

Parameter Code	Parameter name	Parameter detailed description	Minimum Unit	Factory value	Change
FC.20	Frequency linkage selection	0: No linkage ratio 1: FC.21 is the coefficient linkage instruction frequency and acceleration/deceleration 1 2: FC.21 is used as the factor linkage instruction frequency 3: All voltage value is the coefficient linkage instruction frequency and acceleration/deceleration 1 4: All voltage value is used as the factor linkage instruction frequency	1	0	○
FC.21	Linkage ratio factor	0.000~10.000	0.001	1.000	○
FC.22	PI deviation limit	0.0~100.0%	0.1%	0.0%	
FC.23	PI output upper frequency	The PI output target frequency shall not be greater than this upper limit frequency	0.01Hz	50Hz	
FC.24	PI output lower frequency	The PI output target frequency shall not be less than this lower limit frequency	0.01Hz	50Hz	
FC.25	KP1	KP1,KP2: Proportional coefficient of target frequency.The bigger value is, the faster	1	300	
FC.26	KI1		1	300	

Parameter Code	Parameter name	Parameter detailed description	Minimum Unit	Factory value	Change
FC.27	KP2	adjustment is. KI1,KI2: Integral coefficient of the target frequency KP1, KI1 and KP2 ,KI2 are switched by FE-10	1	100	
FC.28	KI2		1	1000	
FC.29	PI Switching point	If the absolute value of bus voltage minus the reference value is bigger than this value, it will switch to KP2、 KI2; otherwise it is KP1、 KI1	1v	30v	
FC.30	PI search interval	The shorter the time is, the faster the tracking is, but also the faster the solar voltage fluctuations	0.1s	2.0s	
Fd group: Virtual terminal parameter function					
Fd.00	VDI1 terminal function selection	Same as F6.00~F6.08 function code setting. Note: The VDI virtual terminal is an extension of the physical input terminal. The communication sends instructions to simulate the actual terminal. Each bit in the communication data represents a terminal, and the value of each bit	1	0	×
Fd.01	VDI2 terminal function selection		1	0	×
Fd.02	VDI3 terminal function selection		1	0	×

Parameter Code	Parameter name	Parameter detailed description	Minimum Unit	Factory value	Change	
Fd.03	VDI4 terminal function selection	represents the status of the corresponding terminal. For specific bit definition, please refer to the communication address 0x1206 description. The function of each terminal cannot be the same. If the functions of the two terminals are set to the same, the physical terminal will act prior to the virtual terminal in order. In this case, the DI ports ranked first will work and the latter ones will not work.	1	0	×	
Fd.04	VDI5 terminal function selection		1	0	×	
Fd.05	VDI6 terminal function selection		1	0	×	
Fd.06	VDI7 terminal function selection		1	0	×	
Fd.07	VDI8 terminal function selection		1	0	×	
Fd.08	VDI9 terminal function selection		1	0	×	
Fd.09	VDI10 terminal function selection		1	0	×	
Fd.10	VDO1 terminal function selection		Same as F6.11~F6.13 function code setting. Note: The VDO virtual terminal is an extension	1	0	×

Parameter Code	Parameter name	Parameter detailed description	Minimum Unit	Factory value	Change
Fd.11	VDO2 terminal function selection	of the physical output terminal. The virtual terminal status can be read only through communication. Each bit in the communication data represents a terminal, and the value of each bit represents the status of the corresponding terminal. For specific bit definition, please refer to the communication address 0x1207 description.	1	0	×
Fd.12	VDO3 terminal function selection		1	0	×
Fd.13	VDO4 terminal function selection		1	0	×
Fd.14	VDO5 terminal function selection		1	0	×
Fd.15	VDO1 output on delay		Same as F6.29~F6.34 function code setting.	0.1s	0.0s
Fd.16	VDO2 output on delay	0.1s		0.0s	○
Fd.17	VDO3 output on delay	0.1s		0.0s	○
Fd.18	VDO4 output on delay	0.1s		0.0s	○
Fd.19	VDO5 output on delay	0.1s		0.0s	○

Parameter Code	Parameter name	Parameter detailed description	Minimum Unit	Factory value	Change
FE group: Solar pump special group 1					
FE.00	Water level control	Unit digit: (Empty- water level control) 0: invalid 1: AI1 2: AI2 Tens digit: (Full water level control) 0: invalid 1: AI1 2: AI2	1	0	○
FE.01	Empty water level threshold	0.0~100.0%	0.1%	75.0%	○
FE.02	Sleep delay in empty-water state	0~10000s	1S	5S	○
FE.03	Wake-up delay in empty-water state	0~10000s	1S	20S	○
FE.04	Full level threshold	0.0~100.0%	0.1%	25.0%	○
FE.05	Sleep delay in full water state	0~10000s	1S	5S	○
FE.06	Wake-up delay in full water state	0~10000s	1S	20S	○

Parameter Code	Parameter name	Parameter detailed description	Minimum Unit	Factory value	Change
FE.07	hydraulic probe damage	0.0~100.0% 0.0%: Invalid. If it is not 0.0%, when the signal is longer than FE.07, it will report fault directly and stop.	0.1%	0.0%	○
FE.08	Pump underload running time	0.0-1000.0s	0.1%	0.0%	○
FE.09	Pump underload current detection coefficient	0.0~2.0	0.1	1.0	○
FE.10	Delay time of sleep weak light	0.0~3600.0s	0.1S	100.0S	○
FE.11	Delay time of wake-up weak light	0.0~3600.0s	0.1S	300.0S	○
FE.12	Adjustment of upper and lower limits time of Vmppt	0.0~10.0s	0.1S	0S	○
FE.13	Adjustment of upper and lower limits of Vmppt	5~100V	1V	30V	○

Parameter Code	Parameter name	Parameter detailed description	Minimum Unit	Factory value	Change
FF group: Solar pump special group 2					
FF.00	Vmpp voltage input selection	0: MPPT 1: voltage digital input	1	1	○
FF.01	Vmpp voltage digital input	0~700Vdc	1V		○
FF.02	Minimum voltage reference	0V~FF-03	1V		○
FF.03	Maximum voltage reference	FF-02~700V	1V		○
FF.04	Emergency deceleration time	0.01s-600.00s	0.01s	0.5s	○

4.2 Monitoring parameter group U0

Parameter Code	Parameter name	Parameter detailed description
U0.00	Output frequency	Displays the output frequency of the current drive
U0.01	Set frequency	Displays the set frequency of the current drive
U0.02	Output current	Displays the output current of the current drive
U0.03	Bus voltage	Displays the bus voltage of the current drive
U0.04	Running speed	Displays the running speed of the current drive Note: Speed = 120*frequency*speed

Parameter Code	Parameter name	Parameter detailed description
		display factor (FC.18)/number of motor poles (F3.11)
U0.05	Linear running speed	Displays the linear running speed of the current drive Note: Linear speed = speed*linear speed display factor (FC.19)
U0.06	Output power	Displays the output power of the current drive
U0.07	Output torque	Displays the output torque of the current drive
U0.08	Output voltage	Displays the output voltage of the current drive
U0.09	AI1	Displays the actual input voltage/current of AI1 of the current drive (when the input is of current type, 1mA current corresponds to 0.5V voltage display)
U0.10	AI2	Displays the actual input voltage of AI2 of the current drive
U0.11	PID setting	Displays the PID target value of the current drive
U0.12	PID feedback	Displays the PID feedback value of the current drive
U0.13	Counter value	Displays the counter value of the current drive
U0.14	Closed-loop pressure display	Displays the closed-loop pressure value of the current drive Note: Closed-loop pressure = PID feedback value*pressure sensor range (F8.23)
U0.15	Actual length	Displays the actual length accumulated by the fixed length control function of the current drive
U0.16	High-frequency pulse count	Displays the accumulated pulse count value of the DI5 high-speed input signal of the current

Parameter Code	Parameter name	Parameter detailed description
	value	drive (not saved after power failure)
U0.17	Pulse frequency display	Displays the pulse frequency of the DI5 high-speed input signal of the current drive
U0.18	Drive rated power	Displays the rated power of the drive
U0.19	Drive rated voltage	Displays the rated voltage of the drive
U0.20	Drive rated current	Displays the rated current of the drive
U0.21	Reserved	-
U0.22	IGBT temperature	Displays the IGBT temperature of the current drive
U0.23	DI terminal status 1	Displays current input terminal function status (defined by bit, 0 indicates that the current terminal input function is invalid, and 1 indicates that the current terminal input function is valid): LED single digit: DI1 input status LED tens digit: DI2 input status LED hundreds digit: DI3 input status LED thousands digit: DI4 input status LED ten thousands digit: DI5 input status
U0.24	Reserved	-

Parameter Code	Parameter name	Parameter detailed description
U0.25	DO terminal status	Displays current output terminal function status (defined by bit, 0 indicates that the current terminal output function is invalid, and 1 indicates that the current terminal output function is valid): LED single digit: DO1 output status LED tens digit: DO2 output status LED hundreds digit: Relay output status LED thousands digit: Reserved LED 10 thousands digit: Reserved
U0.26	Reserved	-
U0.27	Running time accumulation	Displays the accumulated running time of the current drive
U0.28	Software version number	Displays the software version of the current drive
U0.29	Operating state of solar pump	0 :Normal 1 :Empty water state 2 :Full water state 3 :Weak light state

4.3 Fault record parameter group U1

Parameter Code	Parameter name	Parameter detailed description	Factory value	Change
U1.00	Historical fault number	Set range: 0~9 According to the setting of this function code, you can view the fault record information of the last 10 times. By setting different values within U1.01~U1.06, the corresponding fault record will display.	0	○
U1.01	Fault code during fault	Fault record information at the xth fault (x is the set value of U1.00)	-	●
U1.02	Bus voltage during fault		-	●
U1.03	Output current during fault		-	●
U1.04	Running frequency during fault		-	●
U1.05	Running temperature during fault		-	●
U1.06	Fault occurrence time		-	●

4.4 Fault code table

Fault code	Fault type	Fault code	Fault type
E001	overcurrent during acceleration	E016	485 communication error alarm
E002	overcurrent during deceleration	E017	Current detection circuit fault alarm
E003	overcurrent during constant-speed running	E018	Reserved
E004	overvoltage during acceleration	E019	Reserved
E005	overvoltage during deceleration	E020	Closed-loop feedback loss alarm
E006	overvoltage during constant-speed running	E021	Water pressure overpressure alarm
E007	Undervoltage alarm during running	E022	Reserved
E008	Motor overload alarm	E023	Water shortage alarm
E009	Drive overload alarm	E024	Reserved
E010	Reserved	E025	Underload alarm
E011	Reserved	E026	Hydraulic probe damage of empty water
E012	Output phase loss alarm	E027	Hydraulic probe damage of full water
E013	Drive module radiator overheat alarm	E028	Keypad parameter copy error alarm
E014	Rectifier module radiator overheat alarm	E029	Reserved
E015	External fault alarm	E099	Reserved

Appendix I Communication Protocol

Networking mode

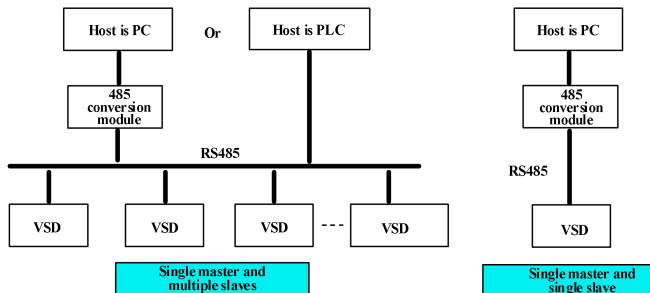

Figure 1 Schematic Diagram of Drive Networking Mode

Interface mode

RS485: asynchronous, half-duplex. Default: 8-N-2, 9600BPS. For parameter setting, please refer to group Fb description.

Protocol format

The Modbus protocol supports both RTU mode and ASCII mode. The corresponding frame format is as follows:

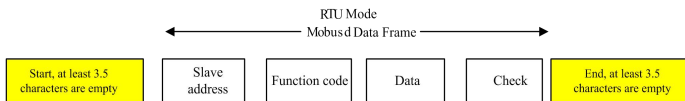

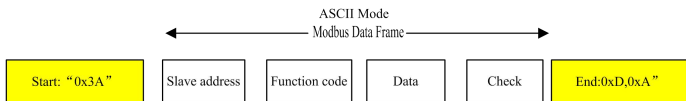

Protocol function:

The main function of Modbus is to read and write parameters. Different function codes determine different operation requests. The drive Modbus protocol supports the following function code operations:

Function code	Function code description
0x03	Read drive function code parameter and running status parameter
0x06	Rewrite function code or control parameter of single drive
0x10	Rewrite function code or control parameter of multiple drives

The function code parameter, control parameter and status parameter of the drive are mapped as Modbus read-write registers. The read-write characteristics and range of the function code parameters follow the instructions in the drive user manual. The group number of the drive function code is mapped to the high byte address of the register, and the index in the group is mapped to the low byte address of the register. The control parameter of the drive is virtualized to the drive function code group 18, and the status parameter of the drive is virtualized to the drive function code group 19. The correspondence between the function code group number and the high byte of its mapped register address is as follows:

Group F0: 0x00; group F1: 0x01; group F2: 0x02; group F3: 0x03; group F4: 0x04; group F5: 0x05; group F6: 0x06; group F7: 0x07; group F8: 0x08; group F9: 0x09; FA group: 0x0A; Fb group: 0x0B; FC group: 0x0C; Fd group: 0x0D; FE group: 0x0E; FF group: 0x0F; U0 group: 0x10; U1 group: 0x11; drive control parameter group: 0x12; drive status parameter group: 0x13.

For example, the register address of the drive function code parameter F3.02 is 0x0302, and the register address of the drive function code parameter FE.01 is 0x0E01.

If the operation request fails, the response is an error code and an exception code. The error code is equal to (function code + 0x80), and the exception code indicates the error reason. The exception codes are listed as follows:

Exception code	Exception code Description
0x1	Illegal function code.
0x2	Illegal register address.
0x3	Data error, that is, the data exceeds the upper or lower limit.
0x4	Slave operation failed (including errors caused by invalid data, although the data is within the upper and lower limits).
0x18	Information frame error: Including information length error and check error.
0x20	Parameters cannot be modified.
0x21	Out of the range of function group.

The drive control parameters can complete functions to start, stop, and set running frequency of the drive. By searching drive status parameters, parameters such as operating frequency, output current, and output torque of the drive can be obtained. The specific drive control parameters and status parameters are enumerated as follows (except 0x1207 virtual output terminal is read-only, other parameters are both readable and writable):

Basic drive control parameter index

Register address	Parameter name	Whether kept saved after power failure
0x1200	Control command word 1	No
0x1201	Main frequency setting	Yes
0x1202	Reserved	-
0x1203	PID target value	Yes
0x1204	PID feedback value	Yes
0x1205	Analog output AO, high-speed DO2 setting	No
0x1206	Virtual input terminal: Defined by bit: BIT0~9 = VDI1~VDI10, BIT10~15 = Reserved	No
0x1207	Virtual output terminals (read-only): Defined by bit: BIT0~4 = VDO1~VDO5, BIT5~15 = Reserved	No
0x2000	Control command word 2	No
0x2001	Main frequency setting	Yes

Basic drive status parameter index

Register address	Parameter name
0x1300	Running status word
0x1301	Drive model

The drive control command word 1 (register address 0x1200) bit is defined as follows:

Control word (bit)	Value	Significance	Function description
Bit2, 1, 0	111B	Run command	Start the drive
	110B	Stop command	Stop according to the way set by function code F2.08
	Remain ing	No command	
Bit3	1	Reverse	Set the running direction when the run command is valid (invalid for jog command)
	0	Forward	
Bit8~Bit4	0	Reserved	-
Bit9	1	Fault reset valid	
	0	Fault reset invalid	
Bit15~Bit10	0	Reserved	-

The drive control word 2 (register address 0x2000) bit is defined as follows:

Control word (bit)	Value	Significance	Function description
Bit1, 0	00B	No function	
	01B	Stop	Stop according to the way set by function code F2.08
	10B	Start	Start the drive
	11B	No function	
Bit3, 2	0	Reserved	-
Bit5, 4	00B	No function	
	01B	Forward instruction	
	10B	Reverse	
	11B	Fault reset	
Bit15~Bit5	0	Reserved	-

The drive status word (register address 0x1300) bit is defined as follows:

Status word (bit)	Value	Description	Remarks
Bit0	1	Drive running	
	0	Drive stop	
Bit1	1	Drive reverse	
	0	Drive forward	
Bit2	1	Reached the main setting	
	0	Not reached the main setting	
Bit7~Bit3	0	Reserved	
Bit15~Bit8	00~0xFF	Fault code	0: Indicates the drive is normal; Not 0: Indicates fault. Refer to the user manual of the drive of relevant type for detailed fault code significance. For example, the fault code for motor overload E008 is 0x08, and for undervoltage is 0x1F.

Application example

The command to start the 1# drive in the forward direction and set the speed to 50.00HZ (internally indicated as 0x1388) is as follows:

	Address	Function code	Register address	Register number	Register content bytes	Register content	Verification code
Request	0x01	0x10	0x1200	0x0002	0x04	0x0007, 0x1388	0x9B98
Response	0x01	0x10	0x1200	0x0002	None	None	0x44B0

5# drive fault reset:

Address	Function code	Register address	Register content	Verification code
0x05	0x06	0x1200	0x0200	0x8C56
0x05	0x06	0x1200	0x0200	0x8C56

Read the running frequency of the 4# drive, and the drive response running frequency is 50.00HZ:

Address	Function code	Register address	Register number or read bytes	Register content	Verification code
0x04	0x03	0x1000	0x0001	None	0x809F
0x04	0x03	None	0x02	0x1388	0x7912

Write the acceleration time 1 (i.e. function code F1.11) of 5# drive to 1.00s, and do not save after power failure.

Address	Function code	Register address	Register content	Verification code
0x05	0x06	0x010B	0x0064	0xF99B
0x05	0x06	0x010B	0x0064	0XF99B

Read the output current of 5# drive, and the drive response output current is 3.00A.

Address	Function code	Register address	Register number or read bytes	Register content	Verification code
0x05	0x03	0x1002	0x0001	None	0x208E
0x05	0x03	None	0x02	0x012C	0x49C9

Calibration relationship of the drive

A) The calibration of the frequency is 1:100

To make the drive run at 50Hz, the main setting shall be 0x1388 (5000).

B) The calibration of the time is 1:100

To make the drive acceleration time be 3s, the function code setting shall be 0x012C (300).

C) The calibration of the current is 1:100

If the drive feedback current is 0x012C (300), the current of the drive is 3A.

Appendix II Solar Pump Drive Instruction

Solar pump drive wiring diagram

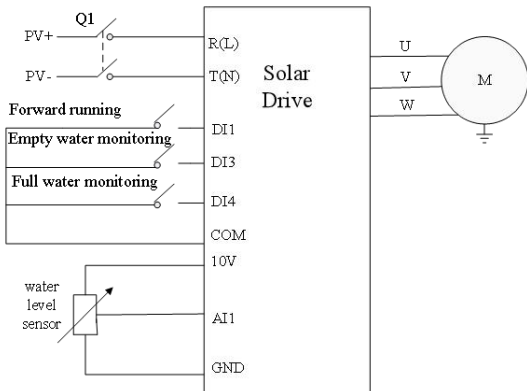

NOTE:

1)The AC power of the grid and the DC power of the PV can not be supplied to the drive at the same time,only one power supply can be chosen

2)The DC breaker Q1 must be installed as the protection switch for PV input

3)When the distance between the PV input component and inverter exceeds 10 meters, type-II surge protection devices must be configured at the DC side

When the distance between the pump and inverter exceeds 50 meters, it is recommended to configure output reactors.

Product Specifications

Drive Model	2S	4T
Input voltage(AC)	220V-250v	380V-440V
Input voltage(DC)	150V-400V	250v-800V
Maximum DC voltage	400V	800V
Recommended DC input voltage range	250V-372V	460V-680V
Recommended MPP voltage	330V	550V

Selection of solar panels

Solar panel voltage Motor voltage	Solar panel connection mode 18V(vpm)	Solar panel connection mode 30V(vpm)
220V	18-20 pcs (connection in series then in parallel)	10-12pcs (connection in series then in parallel)
380V	30-33pcs (connection in series then in parallel)	18-20pcs (connection in series then in parallel)

According to the requirements of required power, each group of solar panels will be used together in parallel

The power of the solar panels is recommended to be 1.3-2.0 times of the rated power of 380v pumps or 1.6-2.0 times of 220v pumps

Warranty Agreement

1. The warranty covers only the drive itself.
2. During normal use, if the drive fails or is damaged within 18 months, the company shall be responsible for repairing:
After 18 months, a reasonable maintenance fee will be charged.
3. The start of the warranty period is the date of manufacture of our company.
4. Within 18 months, a certain maintenance fee shall also be charged if:
 - Unable to follow the operation steps in the user manual causing damages to the drive.
 - The drive is damaged due to flood, fire, abnormal voltage, etc.
 - The drive is damaged due to incorrect wiring, etc.
 - Damages caused by using the drive for abnormal functions.
5. The related service fee is calculated based on actual cost. If there is a contract, the contract shall prevail during treatment.
6. Please keep this card and show it to the repair unit during warranty.

If there are any questions, you can contact the supplier directly or contact our company.

Drive Warranty Form

User unit:	
Detailed address:	
Zip code:	Contact person:
Phone:	Fax:
Machine number:	
Power:	Model:
Contract number:	Date of purchase:
Service unit:	
Contact person:	Phone:
Repairman:	Phone:
Date of repair:	
User comments and evaluation: <input type="checkbox"/> Excellent <input type="checkbox"/> Good <input type="checkbox"/> Normal <input type="checkbox"/> Poor	
Other comments:	
User signature:	Day Month Year
Company return visit records:	
Others:	

Certificate

Inspector: _____

This product is qualified via inspection and is allowed to leave the factory.